

General purpose robot
MOTOMAN-HP20
MOTOMAN-HP20-6

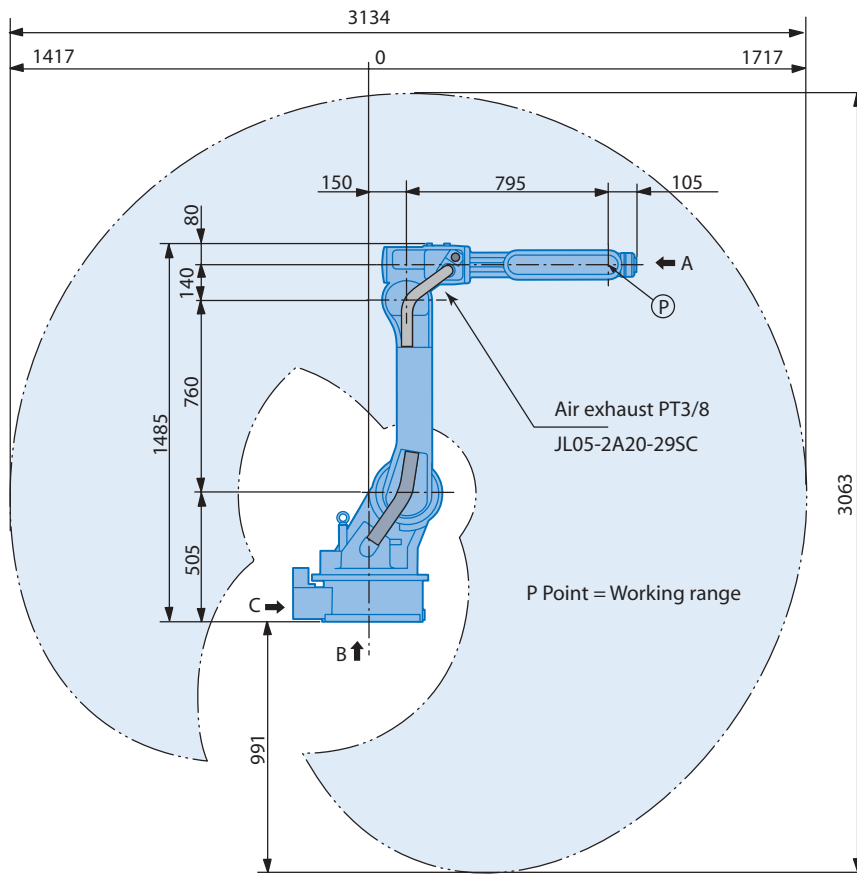

MOTOMAN-HP20



View A

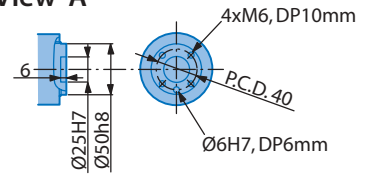

View B

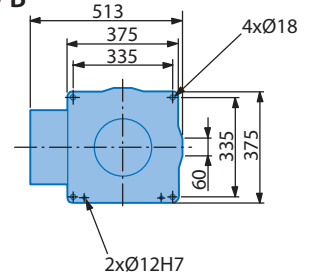

View C

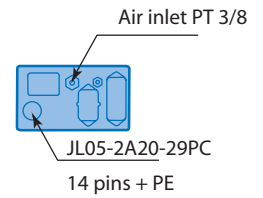

Maximum payload

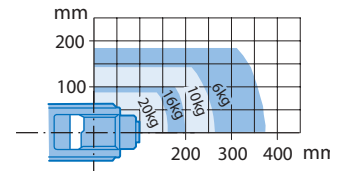

Note

These dimensions are for reference only. Please request detail drawings for all design or engineering requirements.

Technical Specification for MOTOMAN-HP20

Controlled axis	6					
Payload	20 kg					
Repeatability	±0.06 mm	Axis	Motion range	Maximum speed	Allowable moment	Allowable inertia
Weight	280 kg	S	±180°	170°/s	–	–
Power requirements	2.8 kVA	L	+155°, -110°	170°/s	–	–
Mounting positions	Floor, wall ¹⁾ and ceiling	U	+255°, -165°	175°/s	–	–
Wrist unit protection class	IP67	R	±200°	355°/s	39.2 Nm	0.9 kg·m ²
Robot body protection class	IP54 ²⁾ , (IP65 option)	B	±140°	345°/s	39.2 Nm	0.9 kg·m ²
Ambient conditions	0 to +45°C, 20-80% RH	T	±360°	525°/s	19.8 Nm	0.25 kg·m ²

¹⁾ S-axis limitations

²⁾ Floor mounted

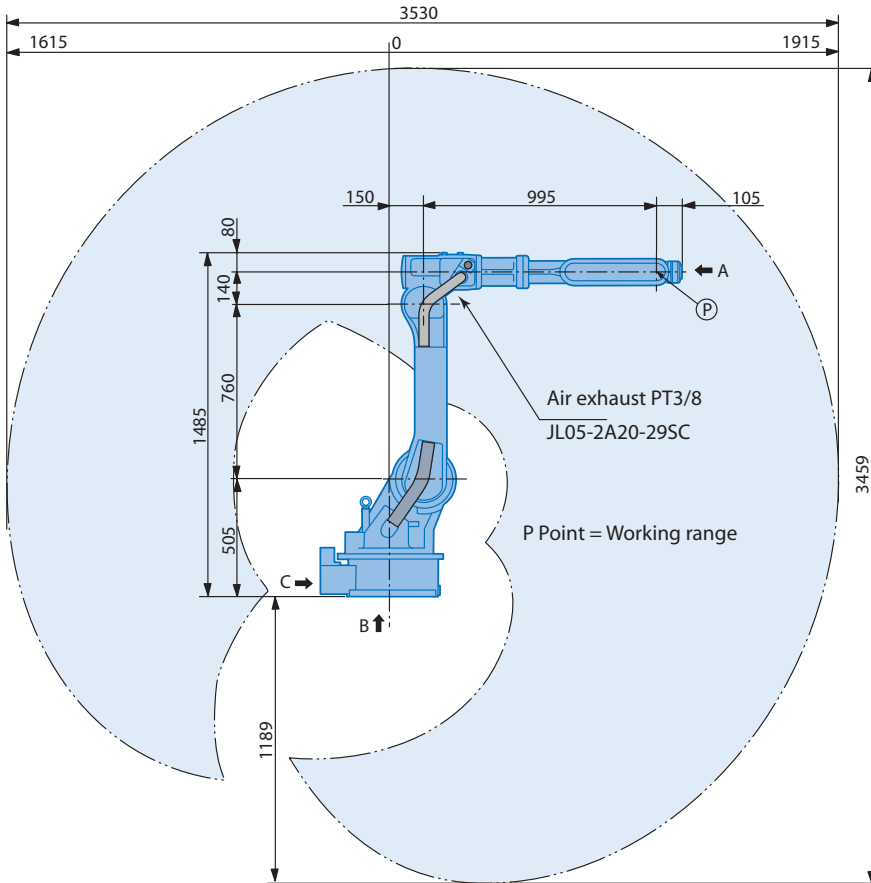

View A

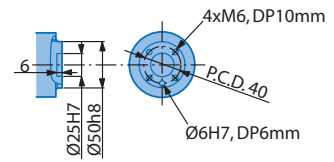

View B

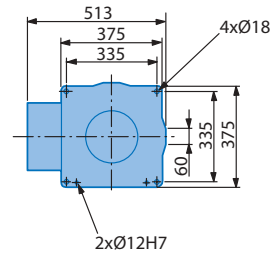

View C

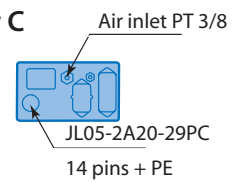

Maximum payload

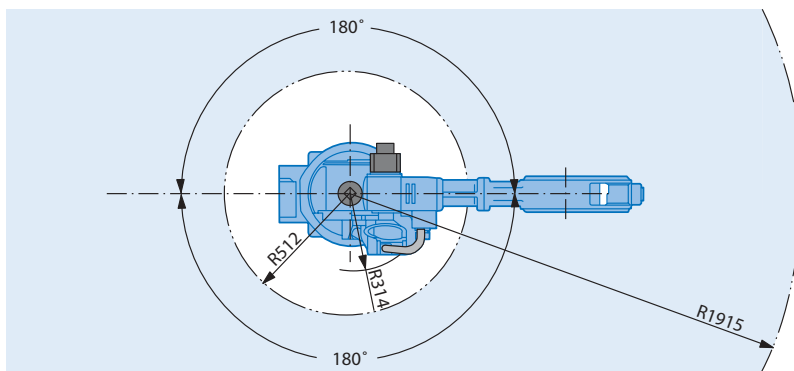
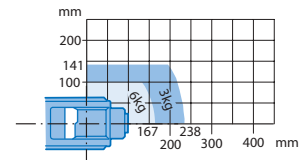

Note

These dimensions are for reference only. Please request detail drawings for all design or engineering requirements.

Technical Specification for MOTOMAN-HP20-6

Controlled axis	6					
Payload	6 kg					
Repeatability	±0.06 mm	Axis	Motion range	Maximum speed	Allowable moment	Allowable inertia
Weight	285 kg	S	±180°	170°/s	-	-
Power requirements	2.8 kVA	L	+155°, -110°	170°/s	-	-
Mounting positions	Floor, wall ¹⁾ and ceiling	U	+255°, -160°	175°/s	-	-
Wrist unit protection class	IP67	R	±200°	355°/s	11.8 Nm	0.24 kg·m ²
Robot body protection class	IP54 ²⁾ , (IP65 option)	B	+230°, -50°	345°/s	9.8 Nm	0.17 kg·m ²
Ambient conditions	0 to +45°C, 20-80% RH	T	±360°	525°/s	5.9 Nm	0.06 kg·m ²

¹⁾ S-axis limitations
²⁾ Floor mounted

Motoman offices and representatives near you

Motoman European headquarters

SE Motoman Robotics Europe AB
Kalmar +46-480-417800

Motoman company group

DE Motoman Robotec GmbH
Allershausen +49-8166-90-0
Motoman Robotec GmbH
Frankfurt +49-6173-6077-30

DK Motoman Robotics Europe AB
Tilst +45 7022 2477

ES Motoman Robotics Iberica S.L.
Barcelona +34-93-6303478

FI Motoman Robotics Finland Oy
Turku +358-40300600

FR Motoman Robotics S.A.
Nantes +33-2-40131919

GB Motoman Robotics UK Ltd
Banbury +44-1295-272755

IT Motoman Robotics Italia SRL
Modena +39-059-280496

PT Motoman Robotics Iberica S.L.
Aveiro +351-234-943 900

SI Ristro d.o.o.
Ribnica +386-61-861113

Distributors

CH Messer SAG
Dällikon +41-18-471717

GR Kouvalias Industrial Robots
Kallithea +30-1-95892436

HU Rehm Hegesztéstechnika Kft
Budapest +36-30-9510065

IL KNT Engineering Ltd
Kfar Azar +972-39231944

NO Optimove as
Lierstranda +47-32240600

PL Roboprojekt Boc Sp.z.o.o.
Siewierz +48-326728952

TR Teknodrom Robotik Otomasyon Ltd.
Gebze, Kocaeli +0090-2626443444

ZA Robotic Systems SA PTY Ltd
Johannesburg +27-11-608318



European Headquarters

Motoman Robotics Europe AB
Franska vägen 10, Kalmar
Box 4004 • SE-390 04 Kalmar, SWEDEN
Phone: +46 (0)480-417 800
Fax: +46-(0)480-417 999

Production unit

Motoman Robotics Europe AB
Verkstadsgatan 2, Torsås
Box 504 • SE-385 25 Torsås, SWEDEN
Phone: +46 (0)480-417 800
Fax: +46-(0)486-414 10

www.motoman.se



Technical data may be subject to change without previous notice · Motoman Robotics Europe AB 2005 · Reg. No. MRS6221GB.1.L

