

H G F E D C B A

4

4

3

3

2

2

1

1

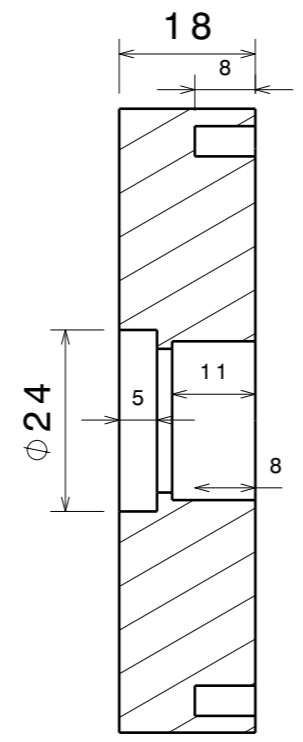
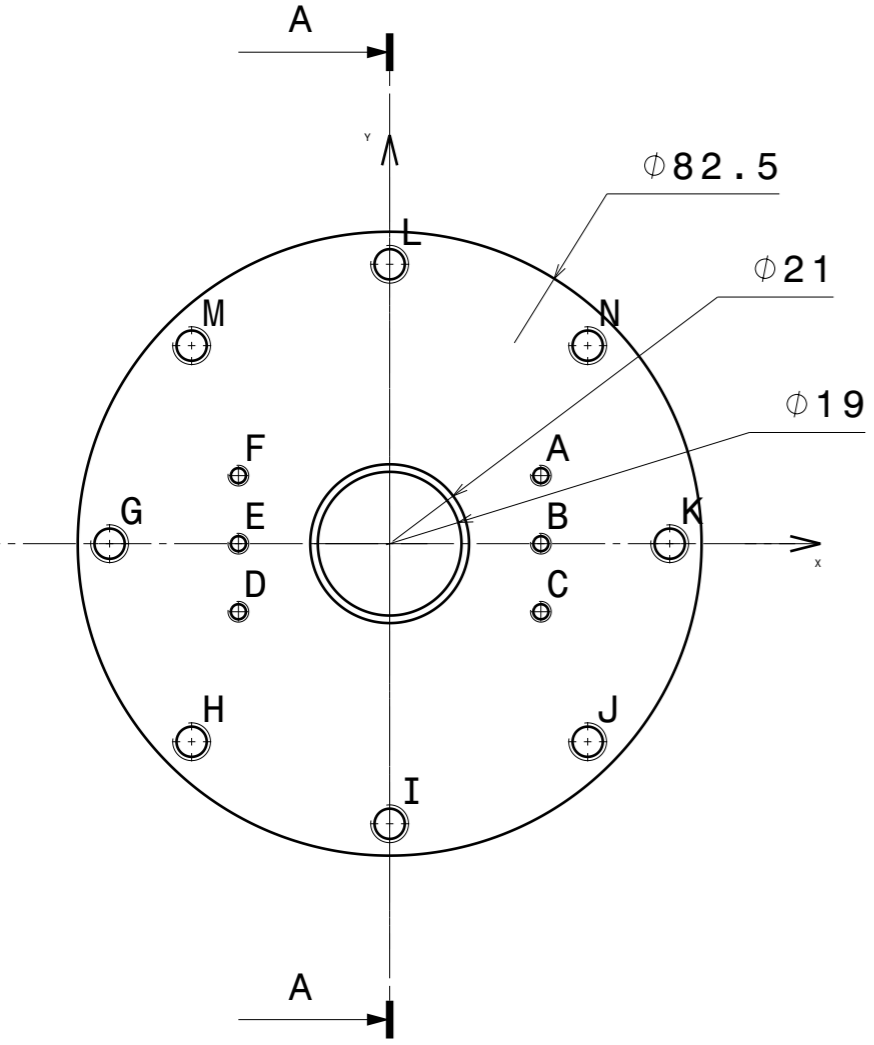

REF.	X	Y	Diameter
A	20	9	2
B	20	0	2
C	20	-9	2
D	-20	-9	2
E	-20	0	2
F	-20	9	2
G	-37.04	0	4
H	-26.19	-26.19	4
I	0	-37.04	4
J	26.19	-26.19	4
K	37.04	0	4
L	0	36.95	4
M	-26.19	26.19	4
N	26.19	26.19	4

H G B A

DESIGNED BY: Tiago Rocha		<h1>Caixa para rolamentos</h1>	I	-
DATE: 05/05/2011			H	-
CHECKED BY:		<h2>Medição da Velocidade - ATLASCAR</h2>	G	-
DATE:			F	-
SIZE A4		<h3>015</h3>	E	-
SCALE 1:2	PART NUMBER		D	-
		SHEET 1/1	C	-
			B	-
			A	-

This drawing is our property; it can't be reproduced or communicated without our written agreement.