

Project: Medição\_Velocidade

Different parts: 27

Total parts: 60

Quantity	Part Number	Number
1	Roda do Carro	1
1	Ligação à Roda	2
1	Suporte para Veio	3
4	Anilha cônica	4
5	ISO 2009 SCREW M6x12 STEEL GRADE A COUNTERSUNK SLOTTED FLAT HEAD	5
1	ISO 2009 SCREW M3x6 STEEL GRADE A COUNTERSUNK SLOTTED FLAT HEAD	6

Quantity	Part Number	Number
1	Veio de suporte da caixa do encoder	7
1	Rótula	8
1	Suporte Rótula	9
1	Suporte Carro	10
2	Rolamento Veio	11
2	Rolamento caixa	12
1	Veio ligação ao encoder	13
1	Anilha	14
1	Caixa para Rolamentos	15
1	Encoder 50ppr	16
1	Caixa do encoder	17
1	Suporte do encoder	18
12	ISO 1207 SCREW M4x6 STEEL GRADE A SLOTTED CHEESE HEAD.3	19
2	ISO 1207 SCREW M3x5 STEEL GRADE A SLOTTED CHEESE HEAD	20
1	ISO 1207 SCREW M3.5x5 STEEL GRADE A SLOTTED CHEESE HEAD	21
6	ISO 1207 SCREW M2x8 STEEL GRADE A SLOTTED CHEESE HEAD.9	22
2	ISO 1207 SCREW M4x8 STEEL GRADE A SLOTTED CHEESE HEAD	23
1	Suporte superior da caixa	25
2	Suporte Lateral da Caixa	26
4	ISO 1207 SCREW M2x10 STEEL GRADE A SLOTTED CHEESE HEAD.19	27
1	ISO 2342 SCREW M3x6 SLOTTED HEADLESS WITH SHANK	24

H G F E D C B A

4

3

2

1

4

3

2

1

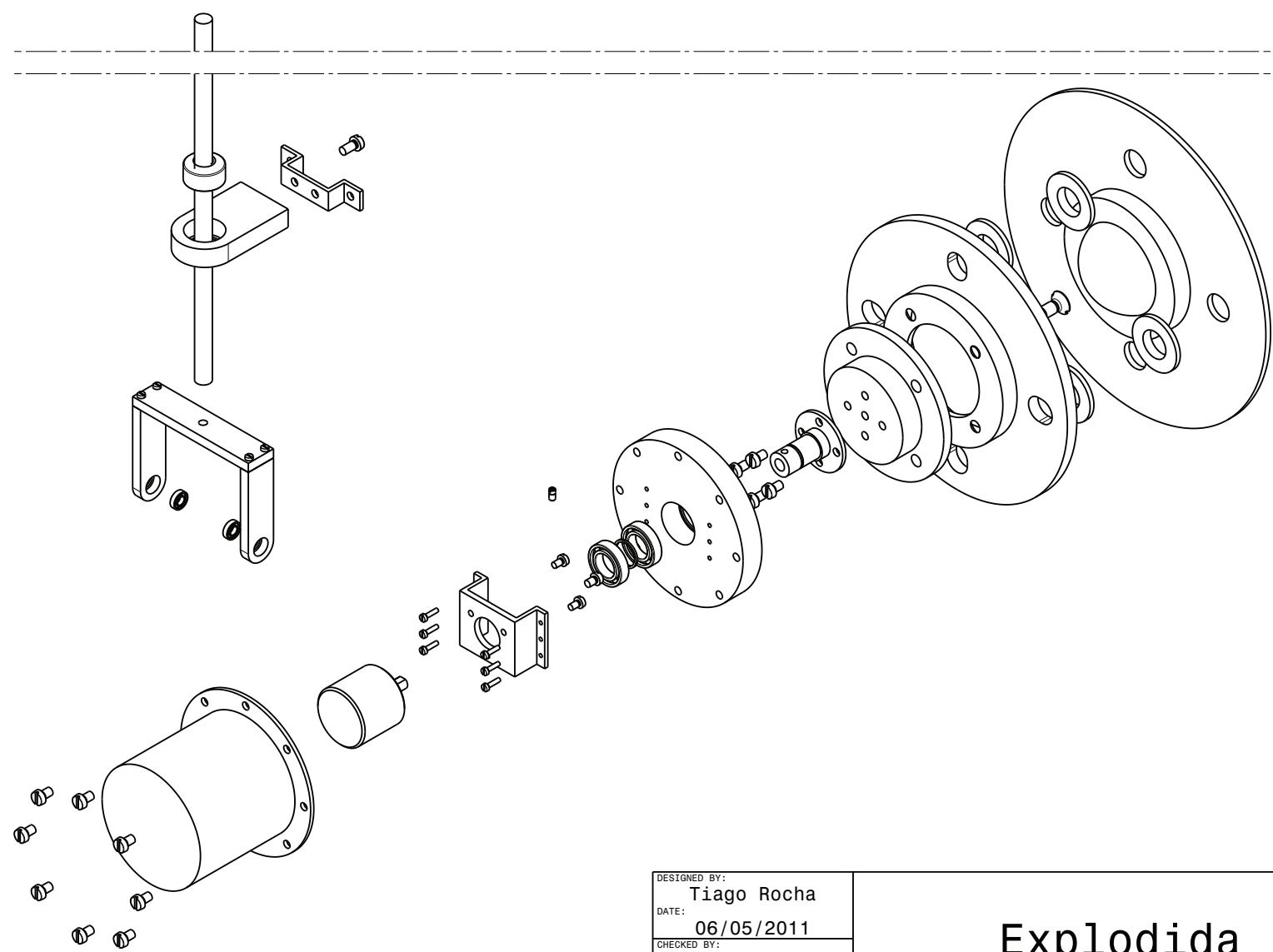

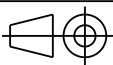
DESIGNED BY: <b>Tiago Rocha</b>		<h1>Explodida</h1>	I	-
DATE: <b>06/05/2011</b>			H	-
CHECKED BY:			G	-
DATE:		F	-	
SIZE: <b>A4</b>			E	-
			D	-
SCALE: <b>1:4</b>		<b>Medição da Velocidade - ATLASCAR</b>	C	-
PART NUMBER:			B	-
			A	-
SHEET: <b>1/1</b>				
This drawing is our property; it can't be reproduced or communicated without our written agreement.				

H G F E D C B A

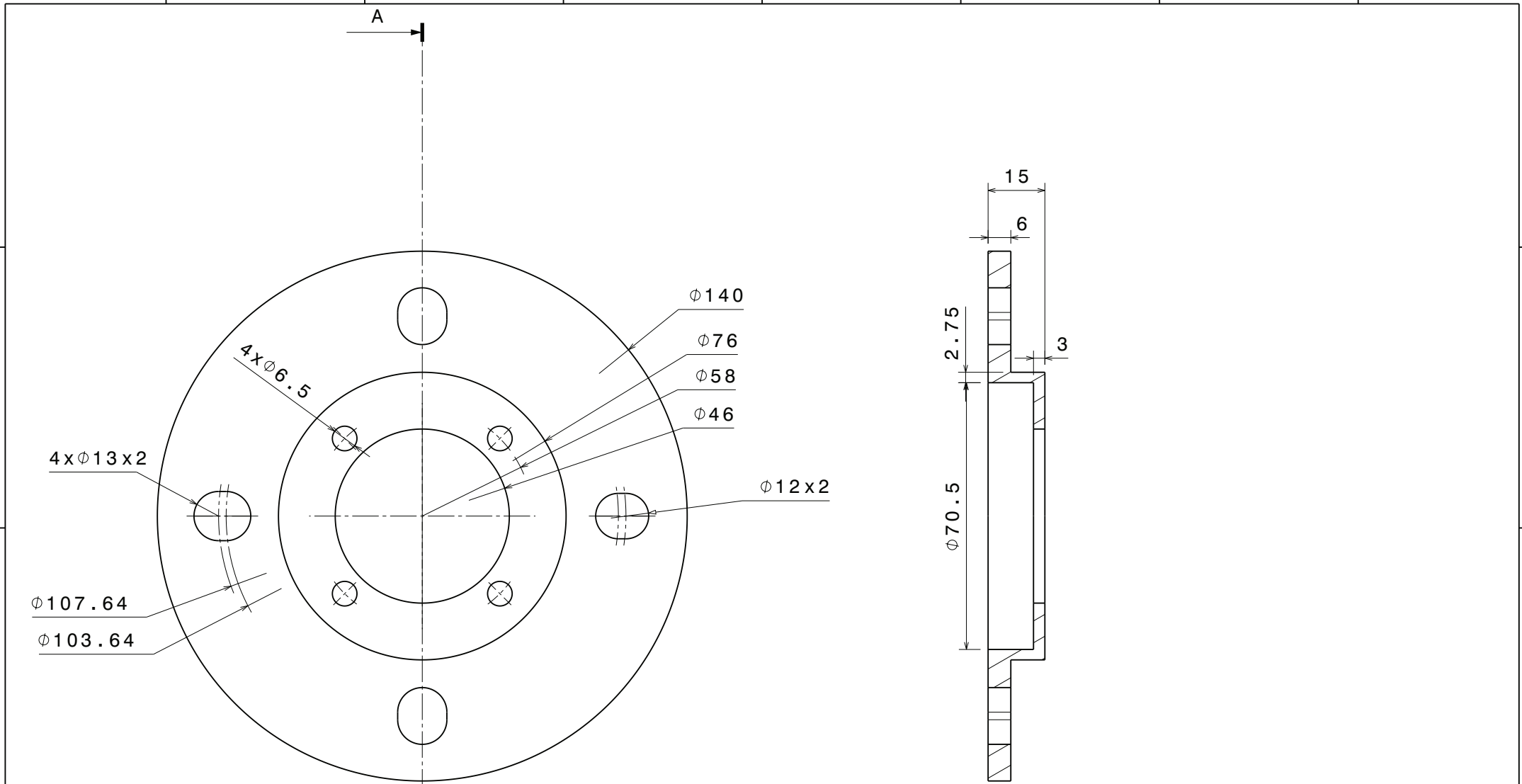

DESIGNED BY:  
**Tiago Rocha**  
 DATE:  
**05/05/2011**  
 CHECKED BY:  
 DATE:

# Ligação à roda

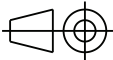
SIZE  
**A4** 

Medição da Velocidade - ATLASCAR

SCALE  
**1:2**

PART NUMBER  
**002**

SHEET  
**1/1**

This drawing is our property; it can't be reproduced or communicated without our written agreement.

I	-
H	-
G	-
F	-
E	-
D	-
C	-
B	-
A	-

1

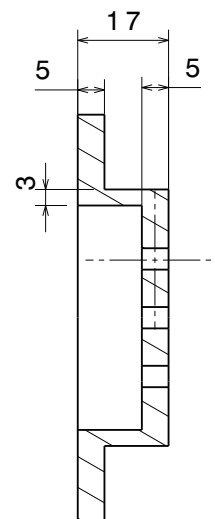
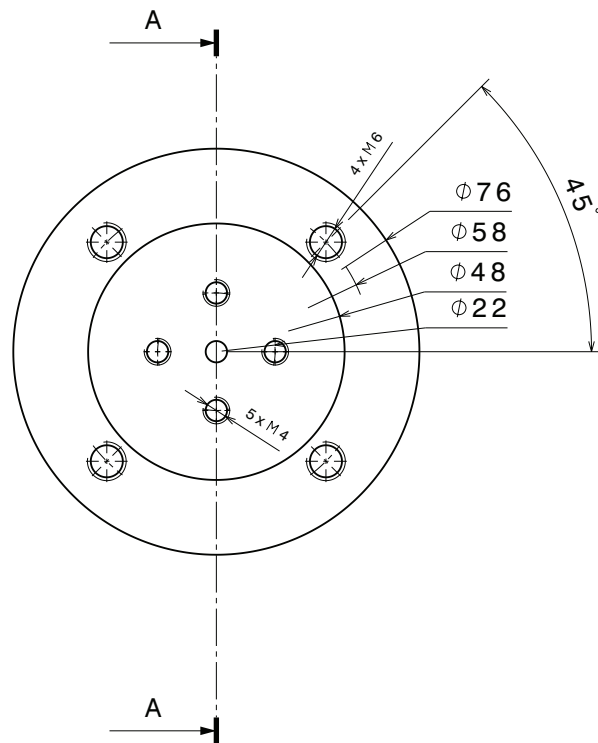

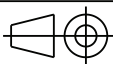
DESIGNED BY: <b>Tiago Rocha</b>		<b>Suporte para veio dos rolamentos</b>	I	--
DATE: 05/05/2011			H	--
CHECKED BY:		Medição da Velocidade - ATLASCAR	G	--
DATE:			F	--
SIZE <b>A4</b>		PART NUMBER <b>003</b>	E	--
SCALE <b>1:2</b>			D	--
		SHEET <b>1/1</b>	C	--
			B	--
This drawing is our property; it can't be reproduced or communicated without our written agreement.			A	--

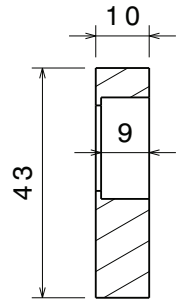
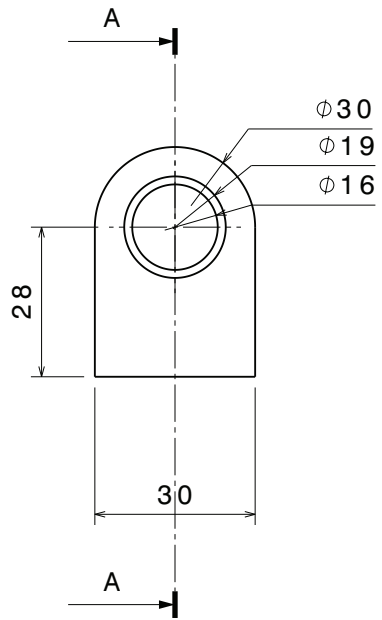
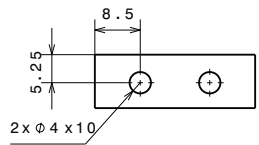

DESIGNED BY: <b>Tiago Rocha</b>		<h1>Suporte da Rótula</h1>	I	-
DATE: 05/05/2011			H	-
CHECKED BY:			G	-
DATE:			F	-
SIZE: <b>A4</b>			E	-
SCALE: <b>1:2</b>			D	-
PART NUMBER: <b>009</b>			C	-
SHEET: <b>1/1</b>			B	-
This drawing is our property; it can't be reproduced or communicated without our written agreement.			A	-

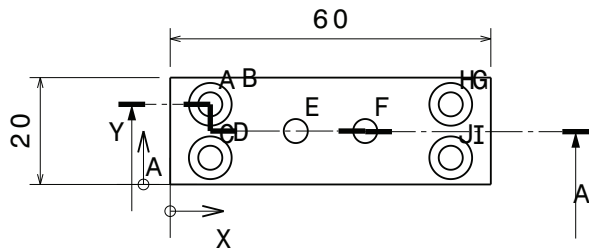
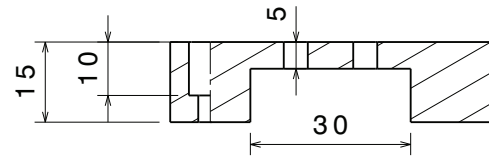

REF.	X	Y	Diameter
A	7.5	15	4.5
B	7.5	15	8
C	7.5	5	4.5
D	7.5	5	8
E	23.5	10	4.5
F	36.5	10	4.5
G	52.5	15	8
H	52.5	15	4.5
I	52.5	5	8
J	52.5	5	4.5

DESIGNED BY: <b>Tiago Rocha</b>		<h1>Suporte Carro</h1>	I	-
DATE: 05/05/2011			H	-
CHECKED BY:			G	-
DATE:			F	-
SIZE <b>A4</b>		<b>Medição da Velocidade - ATLASCAR</b>	E	-
			D	-
SCALE <b>1:2</b>		PART NUMBER <b>010</b>	C	-
		SHEET <b>1/1</b>	B	-
This drawing is our property; it can't be reproduced or communicated without our written agreement.			A	-

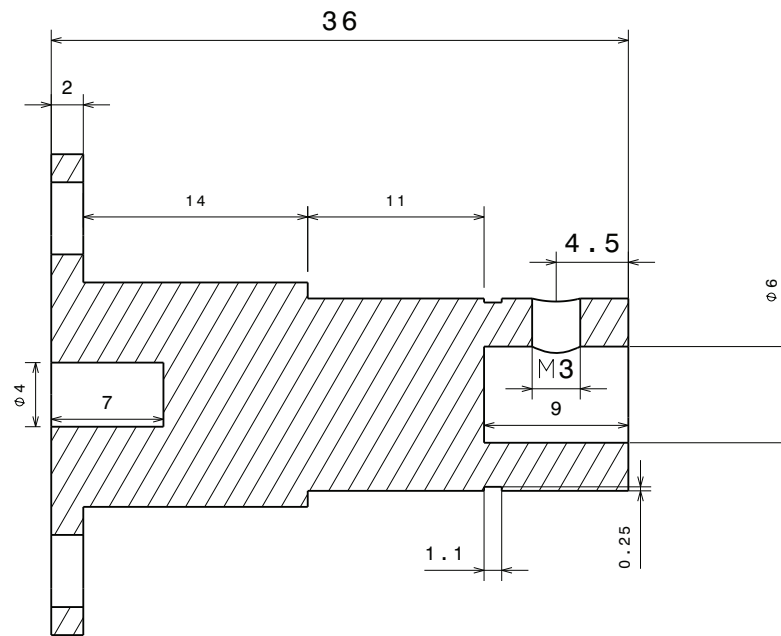
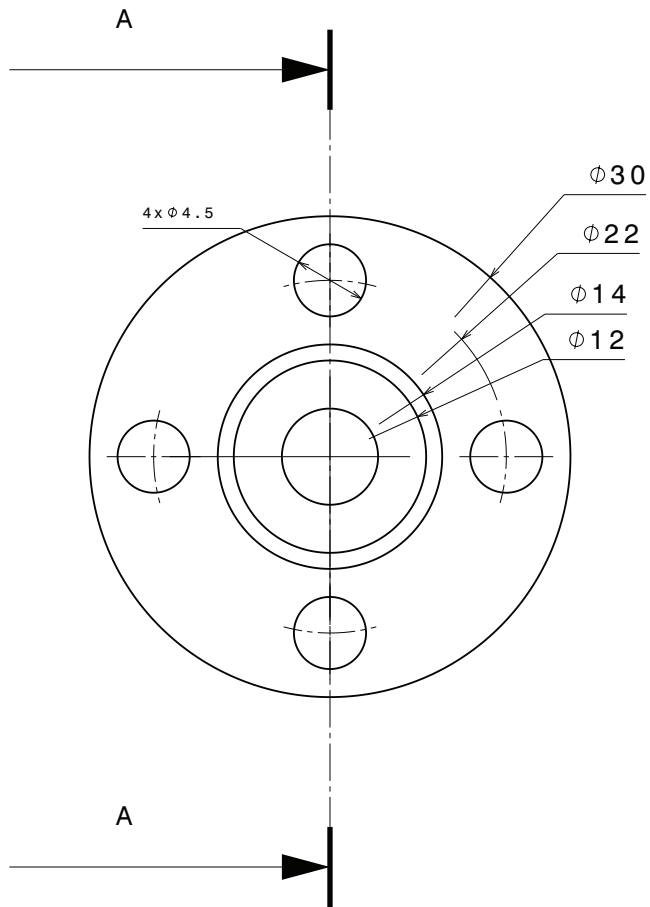

DESIGNED BY: <b>Tiago Rocha</b>	<h1>Veio de Ligação ao encoder</h1>	I	-
DATE: 05/05/2011		H	-
CHECKED BY:	<h2>Medição da Velocidade - ATLASCAR</h2>	G	-
DATE:		F	-
SIZE: <b>A4</b>		E	-
SCALE: <b>3:2</b>		D	-
PART NUMBER: <b>013</b>	SHEET: <b>1/1</b>	C	-
This drawing is our property; it can't be reproduced or communicated without our written agreement.		B	-
		A	-

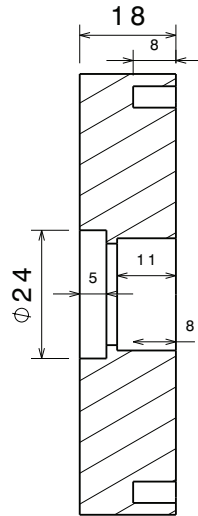
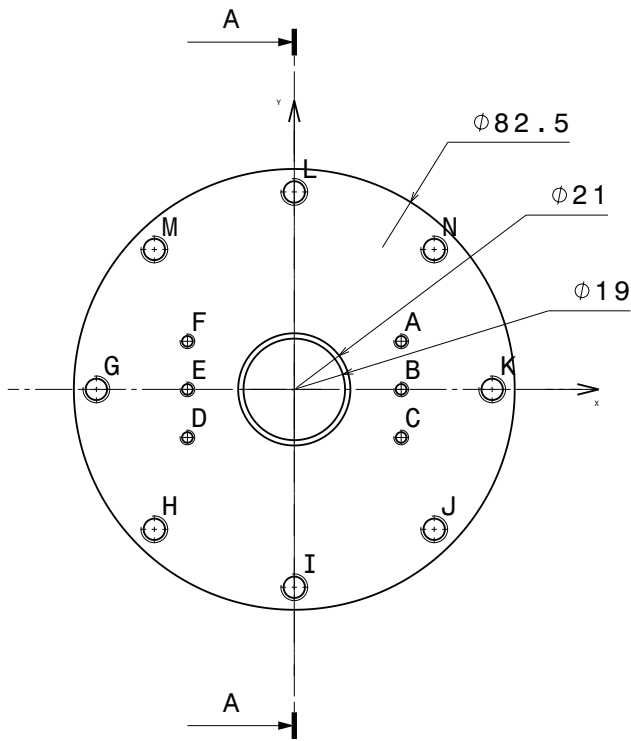

REF.	X	Y	Diameter
A	20	9	2
B	20	0	2
C	20	-9	2
D	-20	-9	2
E	-20	0	2
F	-20	9	2
G	-37.04	0	4
H	-26.19	-26.19	4
I	0	-37.04	4
J	26.19	-26.19	4
K	37.04	0	4
L	0	36.95	4
M	-26.19	26.19	4
N	26.19	26.19	4

DESIGNED BY: <b>Tiago Rocha</b>	<h1>Caixa para rolamentos</h1>	I	-
DATE: 05/05/2011		H	-
CHECKED BY:	<h2>Medição da Velocidade - ATLASCAR</h2>	G	-
DATE:		F	-
SIZE <b>A4</b>		E	-
SCALE <b>1:2</b>		D	-
PART NUMBER <b>015</b>	SHEET <b>1/1</b>	C	-
This drawing is our property; it can't be reproduced or communicated without our written agreement.		B	-
		A	-



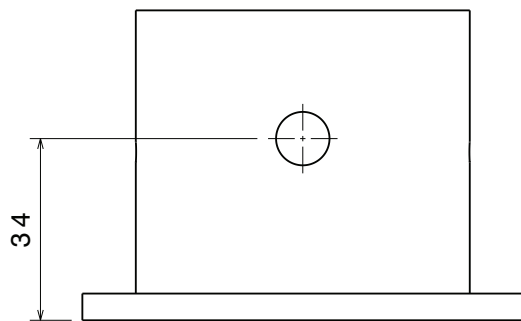
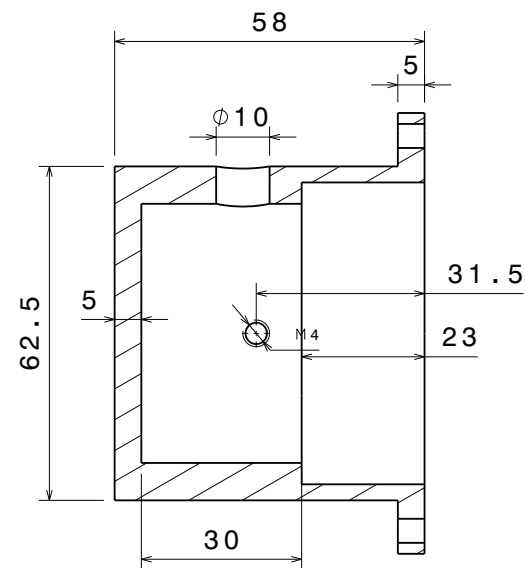
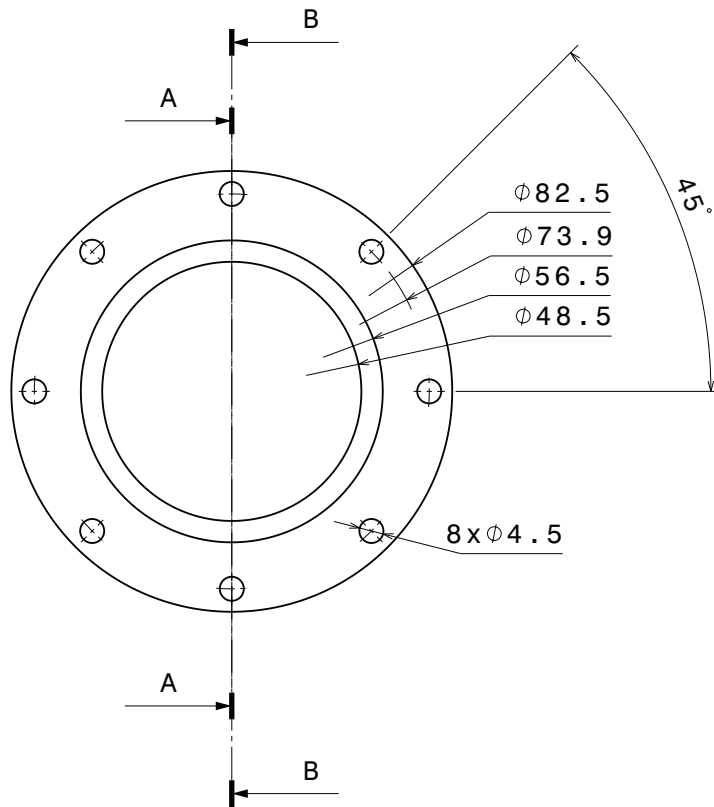
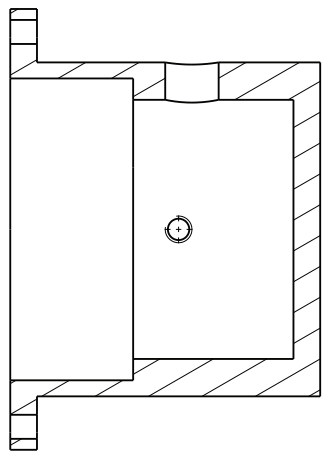

DESIGNED BY:  
**Tiago Rocha**  
DATE:  
**05/05/2011**  
CHECKED BY:  
DATE:

# Caixa para encoder

SIZE  
**A4**



Medição da Velocidade - ATLASCAR

SCALE  
**1:2**

PART NUMBER  
**017**

SHEET  
**1/1**

This drawing is our property; it can't be reproduced or communicated without our written agreement.

I	-
H	-
G	-
F	-
E	-
D	-
C	-
B	-
A	-

4

3

2

1

4

3

2

1

H

G

B

A

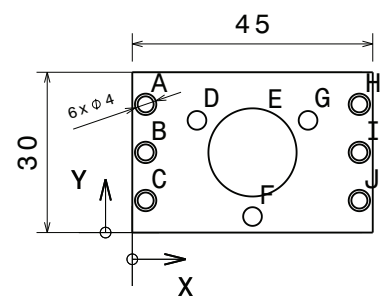
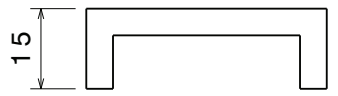

REF.	X	Y	Diameter
A	2.5	24	3
B	2.5	15	3
C	2.5	6	3
D	12.11	21	3.5
E	22.5	15	16.5
F	22.5	3	3.5
G	32.89	21	3.5
H	42.5	24	3
I	42.5	15	3
J	42.5	6	3

DESIGNED BY: <b>Tiago Rocha</b>		<h1>Suporte para encoder</h1>	I	-
DATE: 05/05/2011			H	-
CHECKED BY:			G	-
DATE:		<h2>Medição da Velocidade - ATLASCAR</h2>	F	-
SIZE <b>A4</b>			E	-
SCALE <b>1:2</b>	PART NUMBER <b>018</b>		D	-
SHEET <b>1/1</b>			C	-
This drawing is our property; it can't be reproduced or communicated without our written agreement.			B	-
			A	-

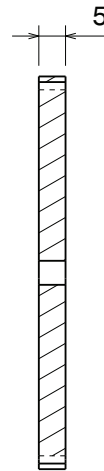
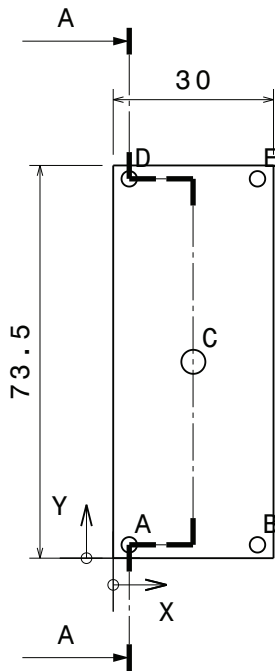

REF.	X	Y	Diameter
A	3	2.5	3
B	27	2.5	2.9
C	15	36.75	4.5
D	3	71	3
E	27	71	3

DESIGNED BY: <b>Tiago Rocha</b>		<h1>Suporte superior da caixa</h1>	I	-
DATE: 05/05/2011			H	-
CHECKED BY:		<h2>Medição da Velocidade - ATLASCAR</h2>	G	-
DATE:			F	-
SIZE <b>A4</b>		PART NUMBER <b>025</b>	E	-
SCALE <b>1:2</b>			D	-
		SHEET <b>1/1</b>	C	-
			B	-
			A	-

This drawing is our property; it can't be reproduced or communicated without our written agreement.

H G F E D C B A

4

4

3

3

2

2

1

1

H G F E D C B A

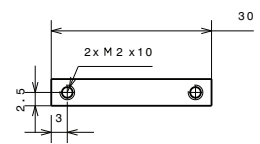
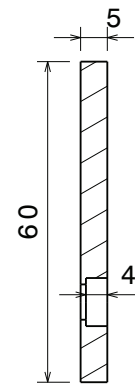
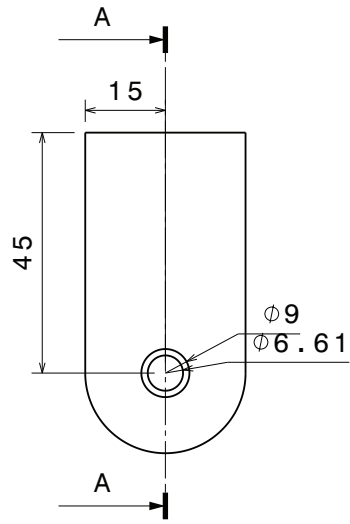

Quantidade: 2 peças

DESIGNED BY: <b>Tiago Rocha</b>		<h1>Suporte Lateral da Caixa</h1>	I	-
DATE: 05/05/2011			H	-
CHECKED BY:			G	-
DATE:			F	-
SIZE: <b>A4</b>		<b>Medição da Velocidade - ATLASCAR</b>	E	-
SCALE: <b>1:2</b>			D	-
PART NUMBER: <b>026</b>			C	-
SHEET: <b>1/1</b>			B	-
This drawing is our property; it can't be reproduced or communicated without our written agreement.			A	-