

FUEL EFFICIENCY AND THE PHYSICS OF AUTOMOBILES¹

Marc Ross,
Physics Department, University of Michigan, Ann Arbor MI 48109-1120

Energy flows and energy efficiencies in the operation of a modern automobile are expressed in terms of simple algebraic approximations. One purpose is to make a car's energy use and the potential for reducing it accessible to non-specialists with technical backgrounds. The overall energy use depends on two factors, vehicle load and powertrain efficiency. The former depends on speed and acceleration and key vehicle characteristics such as mass. The latter depends on heat-engine thermodynamic efficiency, and engine and transmission frictions. The analysis applies to today's automobiles. Numerical values of important parameters are given so that the reader can make his or her own estimates. Various technologies to reduce the energy consumption of automobiles are discussed.

The Need for More-Efficient Vehicles

In the United States, the fuel economy of new automobiles increased 60% from 1975 to 1982. In terms of barrels per day of oil, this efficiency improvement is far larger than production from any oil field. A reasonable estimate of the impact of this change on today's petroleum consumption is obtained by applying the 60% improvement, in average miles per US gallon or km per liter, to today's driving. The result is a *gasoline savings* of 3.3 million barrels per day in the US, more than half the *total crude oil* production in the US of 5.8 million barrels per day.² Fuel efficiency is indeed a powerful way to help energy ends meet.³

Since 1982, however, the fuel economy of new automobiles in the US has stalled at an average test-value near 25 miles per US gallon⁴ and has even been declining (Heavenrich & Hellman 2003). "Automobiles" refers here to passenger cars and light "trucks" under 4 tonnes, like "sport utility vehicles", minivans and pickup trucks. The latter vehicles are in wide use in the US, and almost all, except for full-size pickups, are used in exactly the same ways as passenger cars. That is, few of these so-called trucks are ever driven with

¹ originally published in *Contemporary Physics* 38, no. 6, pp 381-394, 1997. This version is updated in parts to 2004 and modified in parts.

² Annual Energy Review, Energy Information Administration, Tables 5.2 & 5.12c. The estimate is $8.7 \cdot (1 - 1/1.60) = 3.3$ mbd, where 8.7 is motor gasoline usage.

³ This paper is written from a US perspective. In the US, fuel economies were increased to their present levels by regulation. In many other industrial countries, relatively high fuel taxes are, in part, responsible for average fuel economies up to 25% higher than in the US.

⁴ corresponding to 9.4 L/100 km

different loads than cars or are driven off road. But they are not regulated as cars in terms of energy, pollution, safety or taxes. A major reason fuel economy has stalled is the increasing use of these light trucks, whose fuel economy is typically poor. The other reason is that most manufacturers regard the fuel economy standards as ceilings, exploiting efficiency improvements for increased size and performance at the same fuel economy. Meanwhile, driving is increasing 2 to 3% per year. At this rate, US petroleum consumption would double in about 3 decades. This open-ended dependence on petroleum, largely imported, is a major motivation for developing more-efficient vehicles. Emissions also provide a strong motivation.

First good news: Regulation of "criteria pollutant" emissions has led to much cleaner vehicles in the last 30 years. In the US new 2004 vehicles are restricted to emit less than about 2% of their mid-1960s grams/mile levels of hydrocarbons and nitrogen oxides, and less than about 5% of pre-control CO emissions (so-called tier 2 standards)! Those are test levels; real-world emissions of these pollutants were several times higher than the test-levels of the 1990s (Calvert et al. 1994, Ross et al. 1995). Taking into account the growth in travel during this period, the decline in total emissions from new automobiles since the mid 1960s may have been 80 to 90%. This reduction has been accomplished by breakthroughs in catalytic chemistry and sophisticated controls, e.g, of the engine's air-fuel ratio. This reduction has enormously improved health and the simple enjoyment of our metropolitan areas. And while ambient air quality is still not satisfactory in many cities, new automobiles may not have an important role in that.

This good news is balanced by the bad news about greenhouse gas emissions and global climate change. Mobile sources contribute about one-third of the emissions of carbon dioxide in the US, and those emissions are growing. Cleaning up the exhaust cannot reduce the CO₂ emissions the way it does for the criteria pollutants. However, there is a way to enable reductions in these emissions: increased vehicular efficiency, or fuel economy.

In a sense, however, the strongest motivation for higher vehicle efficiency is technological feasibility. Today's capability to design *and manufacture* high-tech products is revolutionary, because of new materials and new kinds of sensors based on microprocessors. Manufacturers are now able to carry out routinely concepts only dreamed of by the automotive pioneers of a century ago. If individual buyers, or society, placed a high value on fuel efficiency, it could be greatly improved at low cost. Let us explore the possibilities.

Overview of the Formalism

The consumption of fuel energy by a vehicle depends on two factors: 1) the vehicle load, the work or power involved in moving the vehicle and operating its accessories, and 2) the energy-efficiency of the powertrain (engine plus transmission).

The powertrain efficiency is the product of the engine's thermodynamic efficiency, η_t , the engine's mechanical efficiency, η_m , and the transmission efficiency :

$$\text{powertrain efficiency} = P_{\text{load}}/P_{\text{fuel}} = \eta_t \cdot \eta_m \quad (1)$$

where P_{load} is the vehicle load and P_{fuel} is the rate of consumption of fuel in energy terms, both in kW. These quantities are all functions of time, some of them sensitively. The vehicle load is the powertrain output: the rate of increase in kinetic energy plus the rate of energy loss in the air drag, tyre drag and accessories.

The thermodynamic efficiency is the fraction of fuel energy converted to work within the engine:

$$\eta_t = (P_{\text{frict}} + P_b)/P_{\text{fuel}} \quad (2a)$$

where $(P_{\text{frict}} + P_b)$ is total work, which consists of output or "brake" work, P_b , and internal frictional work, P_{frict} .⁵

The mechanical efficiency is the fraction of the total work that is delivered by the engine to the transmission:

$$\eta_m = P_b/(P_b + P_{\text{frict}}) \quad (2b)$$

And the transmission efficiency is:

$$\eta_{\text{trans}} = P_{\text{load}}/P_b \quad (2c)$$

except that the accessories are generally driven by the engine without going through the transmission. The relationships are different when the load is negative, in braking.

In the following I address conventional automobiles. I first discuss vehicle load and the engine's thermodynamic efficiency, including a brief listing of techniques for improving both of them. I go on to discuss mechanical efficiency in more detail, with numerical examples. Then I focus on the potential for improving the mechanical efficiency. Finally, I summarize the overall potential for improving fuel economy.

The spirit of the analysis is a physicist's, rather than that of an engineer who is responsible for a vehicle's performance. I want to describe the energy flows accurately enough for general understanding and perhaps conceptual design, not for designing an actual vehicle. The approach is to develop simple algebraic expressions motivated by physical principles, in contrast to the now pervasive analysis based on numerical arrays. Creating an energy analysis in, hopefully, transparent terms should make the issues

⁵ "Thermodynamic efficiency", is not standard terminology. It's often called "indicated" efficiency.

accessible to non-specialists with technical background. Moreover, with the named quantities introduced, it is easier to discuss the important and interesting opportunities for efficiency improvement.

Energy Use by Today's Vehicles

Vehicle Load. Neglecting minor effects, such as wind and road curvature, the instantaneous load is (Gillespie 1992):

$$P_{\text{load}} = P_{\text{tyres}} + P_{\text{air}} + P_{\text{inertia}} + P_{\text{access}} + P_{\text{grade}} \quad (3)$$

Here the terms are in kW, and are:

a) power overcoming rolling resistance: $P_{\text{tyres}} = C_R M g v$

where C_R is the dimensionless coefficient of rolling resistance⁶, M is the mass of the loaded vehicle, expressed in tonnes; and v is the vehicle speed in m/s;

b) air drag: $P_{\text{air}} = 0.5 C_D A v^3 / 1000$

where ρ is air density (roughly 1.2 kg/m³), C_D is the dimensionless drag coefficient, and A is the frontal area in m²;

c) inertia: $P_{\text{inertia}} = 0.5 M^* [v^2 / t]$

where M^* is the effective inertial mass, about 1.03M, which includes the effect of rotating and reciprocating parts,⁷ and $[v^2 / t]$ is in m²/s³;

d) vehicle-accessories (such as lights, radio, windshield wipers, power steering and air conditioning): P_{access} ; and

e) grade: $P_{\text{grade}} = M g v \sin \theta$

where $\tan \theta$ is the grade. The inertial and grade terms may be negative.

The instantaneous output power required of the engine, P_b , is P_{load} / η , eq(2c). The engine output required in a 1995 Ford Taurus is shown in Fig. 1 for: 1) sustained hill climbing on a 6% grade, the highest grade normally found on a motorway or expressway, 2) sustained driving at constant speed on level ground, and 3) accelerating 3 mph/s, or almost 5 (km/h)/s, on the level. The graph demonstrates that, as of 1995 US driving, 50 kW would suffice for

⁶ C_R is often considered to have some v dependence.

⁷ Strictly speaking, this effective mass depends on the engine speed to vehicle speed ratio. E.g., in low gears the ratio of the speed of reciprocating parts to vehicle speed is relatively high.

sustained driving in almost all situations, while the 105 kW or higher capability provided in the average US car enables one to accelerate rapidly at speeds well above most legal limits.⁸

For current "midsize" US cars, like the 1995 Ford Taurus, the time-average load on the engine in the composite US urban and highway driving cycle is $P_b = 6.3 \text{ kW}$.⁹ In terms of gasoline 6.3 kW is equivalent to 1.6 L/100 km or 0.67 US gallons per 100 miles. If it weren't for the inefficiencies of the powertrain, the fuel economy would be astonishingly good. Nevertheless, major fuel savings can still be achieved by reducing the load, especially weight reduction.

Figure 1. Engine Power Requirements, 1995 Ford Taurus

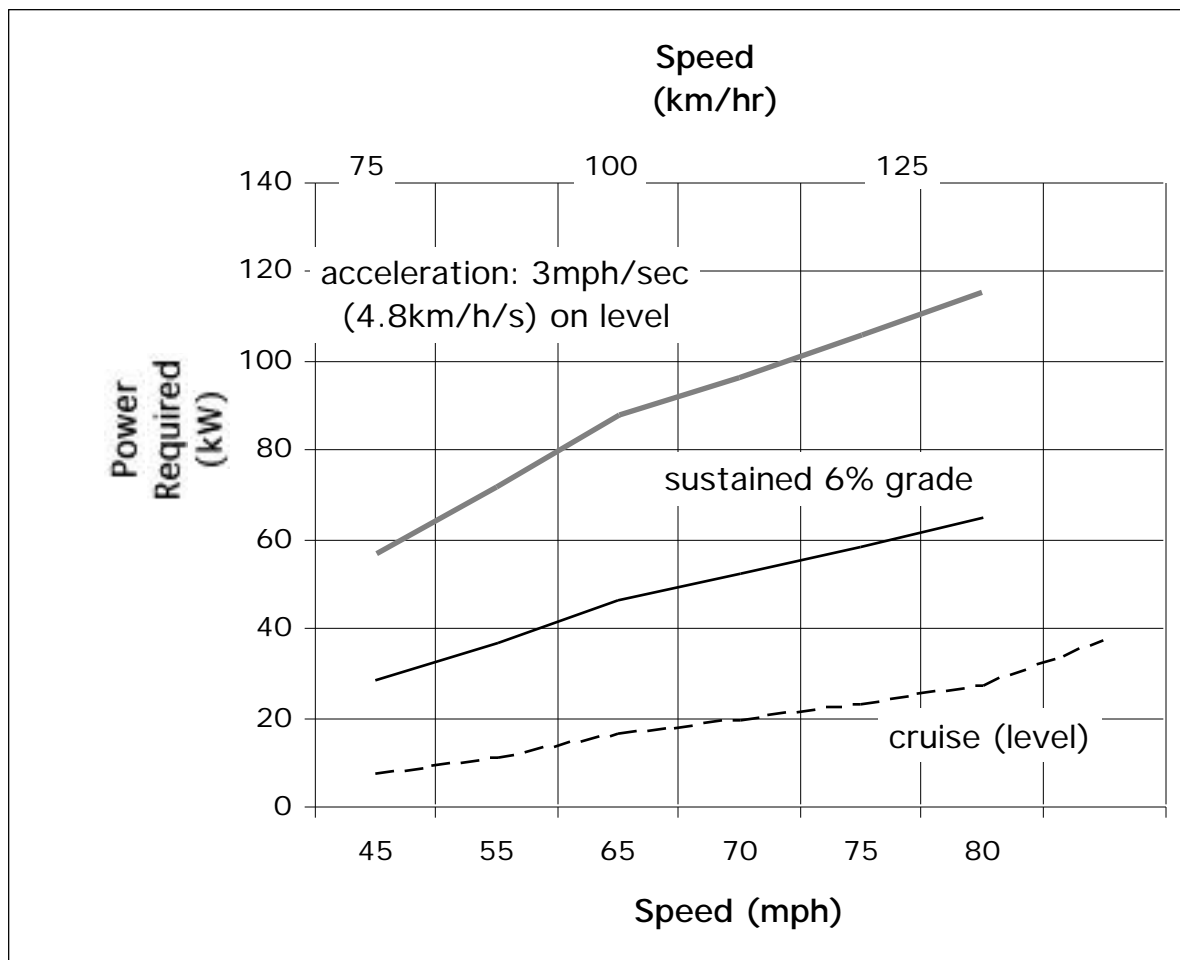

⁸ The figure is calculated using eq(3) with parameters given below. The transmission efficiency is taken to be $\eta = 0.9$, and engine speeds are simplified in the calculation.

⁹ A driving cycle is a sequence of second-by-second vehicle speeds often used to define vehicle performance for regulatory purposes.

All the vehicle loads in eq(3) can be substantially reduced through improved design, and (for weight and tyre loss) through improved materials. We have studied current cost-effective technologies, keeping the car's interior volume fixed. We found that, relative to model-year 1990 averages, rolling resistance could be reduced one-third, air drag one-quarter, and weight one-fifth (DeCicco & Ross 1993). Based on that analysis for the composite US driving cycle, the overall load can be reduced 27% relative to vehicles like the one described in detail below.

This weight reduction is a simple estimate based on early 1990s production-model designs; it grossly underestimates what could be done with new materials, and new designs such as sandwich panels (e.g. reinforced sheets with foam filling), small engines with high power-to-displacement capability, and small transmissions such as the double clutch automatics.

Unlike the efficiency of the powertrain there is *no ultimate limit to load reduction*. Traveling in vehicles with steel wheels on steel rails in an evacuated tunnel would involve very small loads indeed. The situation is analogous to heating a building in cold weather. The efficiency of the heating system is bounded by 100% (ignoring heat pumps). But the load can be reduced as much as desired. It is mediated by the building envelope, which could be very thick, with high thermal insulation, and with a ventilation system using excellent heat exchangers.

Thermodynamic efficiency of the engine. The ability of energy to do work declines dramatically with combustion, i.e. when fuel energy is converted to thermal energy. The elegant second-law concepts of available work and lost work were introduced by Gibbs to describe such situations (AIP 1974), and applied to automobile engines by Keenan and others (Keenan 1948). Briefly: while high-quality forms of energy can, in principle, be converted entirely into work, thermal energy cannot. The available work content of thermal energy is the maximum work that could in principle be done in particular surroundings, such as the neighboring air at a given temperature. Decreases in available work associated with irreversible processes like combustion are counted as lost work. While the escape of gas from confinement at high pressure is the most commonly cited example of irreversibility, combustion is another excellent example. The lost work that results is large.

Why not use a technology which directly converts a fuel's chemical energy into work? A fuel-driven battery, or fuel cell, does so. It converts fuel to electricity without the intermediate step of combustion; so its efficiency is not necessarily limited by the second law to be much less than 100% (Karthan & Grimes 1994). But, at present, fuel-cell technology is complicated and expensive. When it becomes well developed, vehicle engines with thermodynamic efficiencies over 50% should be achieved. In the meantime, we will continue to use a less-sophisticated technology based on combustion.

A typical modern spark-ignition engine's structure is illustrated schematically in Fig. 2. Air is admitted to each cylinder through two valves, a throttle common to all the cylinders followed by an inlet (or intake) valve (or valves) for each. Fuel is injected outside the cylinder near the inlet valve. In each full cycle the piston goes through four strokes, and the crankshaft goes through two revolutions. The strokes are illustrated in the pressure-volume diagram, Fig. 3.

Figure 2. Sketch of a Cylinder and Intake System

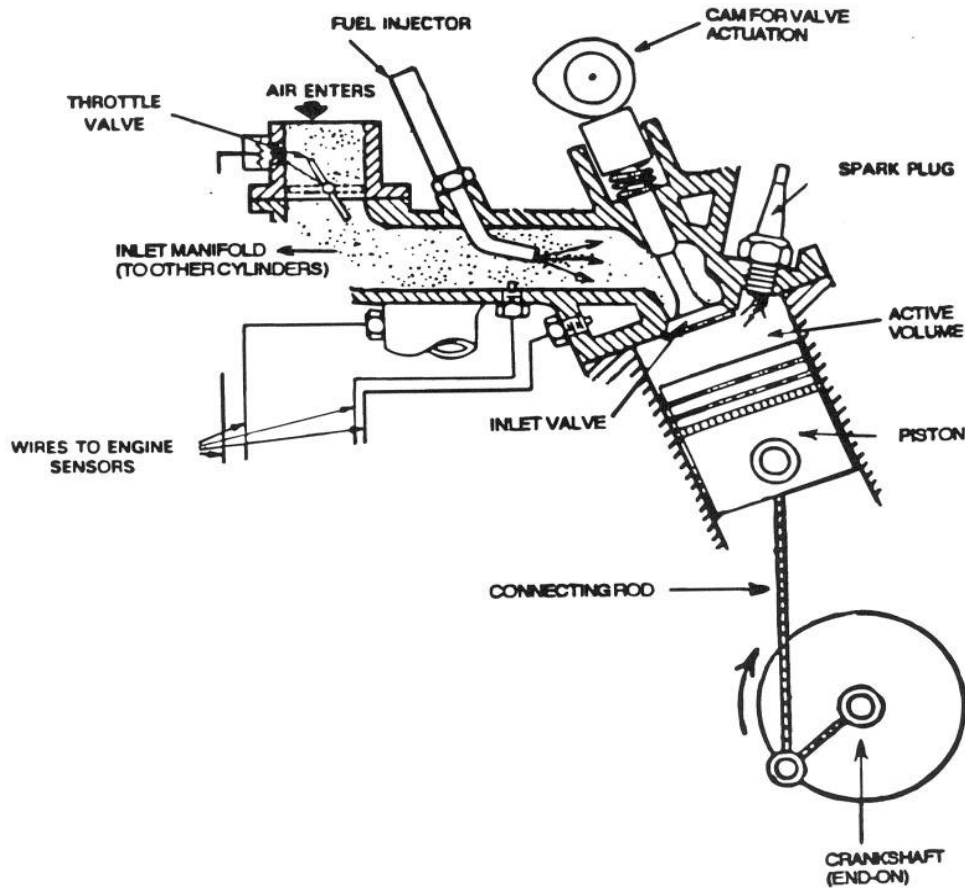

The thermodynamic efficiency is broadly defined by eq(2a). In particular, we take it to be the net work, relative to fuel input, done by the compression-expansion strokes in the pressure-volume diagram (Heywood 1988, Stone 1992). This work moving the pistons is the area $p dV$ between the two upper curves in Fig. 3. And η is that work as a fraction of the fuel energy.

In an Otto cycle, the compression and expansion strokes are assumed to be adiabatic with a constant volume segment at the end of each. The constant volume assumption is motivated by the slow rate

of change in the active volume when the piston is near either end of its motion. (See Fig. 2.)

Figure 3. Pressure-Volume Diagram (Four Stroke Spark Ignition Engine)

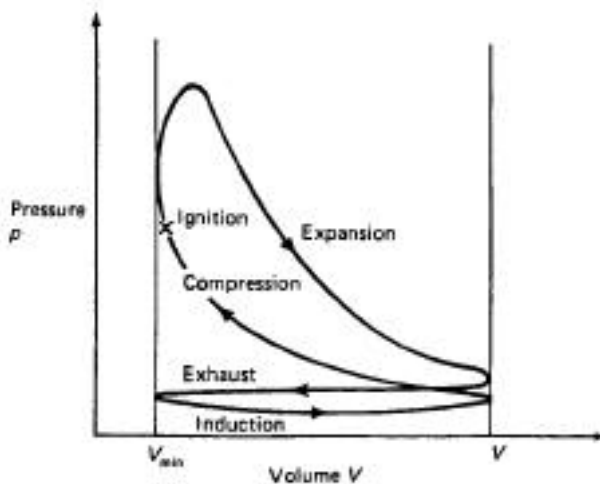

With an ideal gas as the thermodynamic fluid, the Otto cycle efficiency is:

$$\tau_I = 1 - 1/r_c^{\gamma} \quad (4a)$$

where r_c is the compression ratio, V_{max}/V_{min} , and $\gamma = c_p/c_v$, as discussed in many thermodynamics texts. (See, e.g., Zemansky & Dittman 1981.) The thermodynamic efficiency increases with increasing compression ratio and with increasing c_p/c_v . The latter is related to the fraction of the thermal energy which goes into translational motion of the gas molecules, i.e. to increased pressure, as opposed to going into other molecular degrees of freedom. Thus, stable diatomic molecules make a much better thermodynamic fluid than complex molecules.

Texts on internal-combustion engines also discuss fuel-air-cycle efficiencies, which still involve simplified cycles but use measured thermodynamic properties of the gases, including effects of dissociation at high temperature. The fuel-air cycle defined by the outer envelope in Fig. 4 is still essentially an Otto cycle, with constant volume ends and adiabats connecting them. The corresponding efficiency, τ_{FA} , is calculated numerically as a function of r_c and ϕ . To a fairly good approximation:

$$\tau_{FA} \approx (1 - 0.25/\phi) \tau_I \quad (4b)$$

where ϕ is the fuel-air ratio relative to stoichiometric (Taylor 1985, v 1, p 95).¹⁰ The ϕ dependence represents the same issue of

¹⁰ At the stoichiometric fuel-air ratio, all the initial oxygen and fuel could combine to form water and carbon dioxide.

conversion of thermal energy into increased pressure as in eq(4a). At the stoichiometric point, near which today's spark-ignition engines normally operate, eq(4b) shows $\tau_{FA} = 0.75 \tau_I$. This loss of efficiency occurs because the fluid is not an ideal gas and because it doesn't have as large a value of c_p/c_v as air. Note that the efficiencies (4a) and (4b) do not depend on engine operating point, i.e. on speed and power.

The thermodynamic efficiency of an actual engine, τ , is roughly 0.8 times that of the fuel-air cycle. The ways in which capacity to do work is lost relative to the fuel-air cycle are: 1) heat loss, heat escaping through the cylinder walls, 2) combustion-time loss, delay of some combustion until well into the expansion stroke, 3) exhaust blowdown, pressure release when the exhaust valve is opened and, in addition, 4) fuel that is not burned within the cylinder. The first three reductions in the area of the p-V loop are illustrated in Fig. 4; heat loss is the largest. As for the fourth loss, in engines controlled to operate stoichiometrically, unburned fuel measured in the exhaust is 1 to 2% of the fuel input; but the actual loss is higher because some burning takes place as the gases leave the cylinder.

Figure 4. Pressure-Volume Diagram and Lost Work in the Compression and Power Strokes

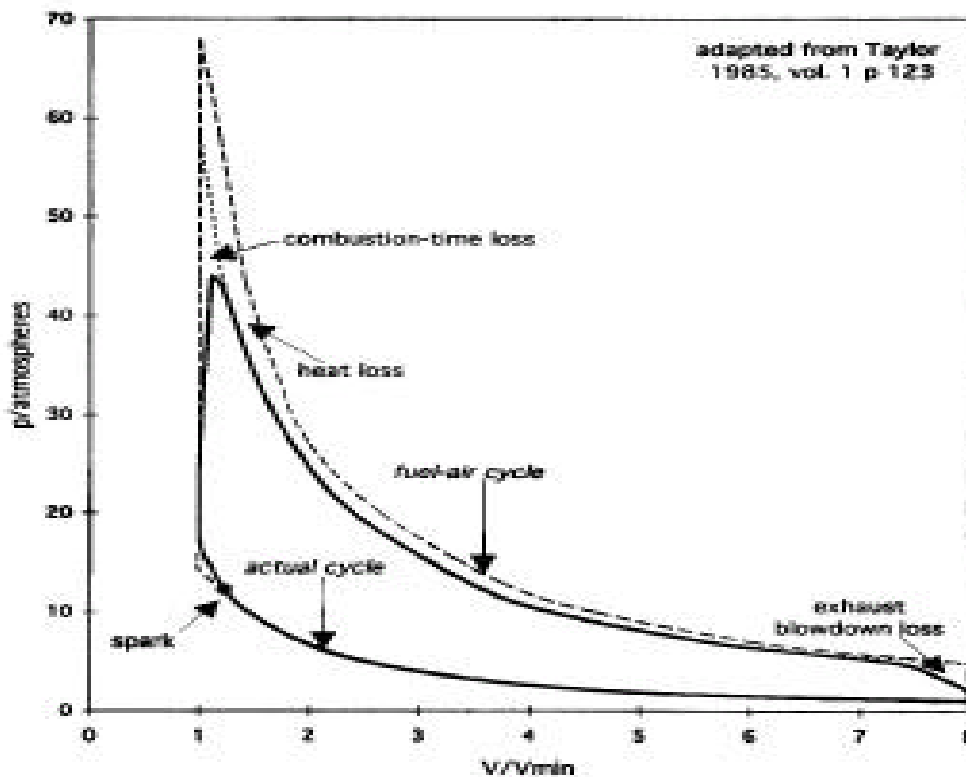

Let the effective heat loss, relative to the heat released by the fuel, be Q ; and let losses (2)-(4) be approximately represented by a constant efficiency, η_c .¹¹ Then, for a real engine:

$$\eta = \eta_{FA} \cdot \eta_c (1 - Q) \quad (4c)$$

In stoichiometric operation, typical values are $\eta_c = 95\%$, and $Q = 15\%$ (Muranaka et al. 1987). Q increases with decreasing cylinder size as the surface to volume ratio increases; and it declines with declining fuel-air ratio and increasing engine speed. The variation of Q is of interest in exploring novel engines.

The best thermodynamic efficiency of conventional spark-ignition gasoline engines is $\eta = 38\%$, relative to the lower heating value of the fuel (or 35% relative to the higher heating value).¹² For comparison, boilers and steam turbines at electric power plants are at most 40 percent efficient, and these engines are large, expensive, and stationary. In new combined-cycle power plants, involving recovery of work from the exhaust of the main combustion turbine, 50 percent efficiency is being achieved; and 60% performance is being sought through truly elaborate schemes. (The latter efficiencies are based on the higher heating value of fuel.)

I am making two points with these comparisons: First, cost restricts automotive efficiencies; an automobile engine costs about \$20/kW, while the corresponding part of a power plant costs perhaps \$500/kW. Second, substantially increasing the thermodynamic efficiency is difficult for any engine based on combustion; it can never approach 100%.

The most practical measure to increase the thermodynamic efficiency of automotive engines is to increase the fraction of heat that increases the pressure, e.g. to have more of the thermodynamic fluid be air or, in practical language, to use a lean fuel-air mixture. In typical driving, η might be improved this way by as much as a factor 1.15, e.g. η increasing to almost 44% from the 38% characterizing the best conventional gasoline engines.

The most widely used lean-burn engine is the diesel, another lean-burn engine is the new direct-injection stratified charge (DISC) engine, which uses spark-ignition. In compression-ignition, or diesel, engines the fuel has low volatility and is in the form of small droplets after injection into the cylinder. Combustion initiates on droplet surfaces at the high temperature and pressure. The timing of combustion is controlled by the injection. Power

¹¹ The heat loss is "effective" to the extent that it occurs at the beginning of the power stroke, which most of it does. Thus the upper bold curve in Fig. 4 is still essentially adiabatic except near minimum volume.

¹² The lower heating value (LHV) is based on the water resulting from combustion being a gas in the final state; the higher heating value (HHV) is based on water as a liquid. In vehicles extraction of the heat of condensation isn't practical so it is conventional to use LHV.

output is controlled by the amount of fuel injected. There is no throttle, the same amount of air being introduced in every cycle. At low power, the fuel-air ratio is far below stoichiometric. But in spite of their efficiency advantage, diesel engines have not caught on for autos in the US because they have higher nitrogen oxide and particulate emissions and they are heavier. Ten years ago, their exhaust was apparent to anyone walking a main street in London.¹³

In order for the flame front to advance from the spark throughout the cylinder in standard spark-ignition engines, the fuel is vaporized, and mixed well with air. Power output is controlled frictionally using the throttle, which creates a partial vacuum in the inlet manifold (Fig. 2). At the same time the amount of injected fuel is adjusted to obtain the desired fuel-air ratio. In the DISC engine, making use of the control possible with direct injection, turbulence and a spatially-varying fuel concentration enable the combustion to be reliable at fuel-air ratios down to about one-third stoichiometric.¹⁴ The DISC engine is in its infancy so it is early to make judgments; but it appears to have a substantial advantage over the diesel in the potential for emissions control, while it cannot be quite as energy efficient. An alternative to achieving some of the efficiency advantage of lean-burn engines at low power is to recirculate much of the exhaust back into the cylinders (Lumsden et al. 1997).

Another way to improve thermodynamic efficiency is to change the shape of the pressure-volume diagram. One way is to adopt a longer stroke so that the expansion is more fully exploited, but the compression ratio experienced by the gases is kept the same by keeping the inlet valve open in the initial stage (the Miller and Atkinson Cycles now being introduced by Mazda and Toyota). While higher compression ratios increase efficiency in principle, as shown by eq(4a), they cause knock and involve increased friction. Yet another possibility is to modify the engine fundamentally to recover work from the hot exhaust gas in analogy with combined-cycle power plants. Turbocharging offers such an opportunity, but the gain has been modest so far; the primary purpose of turbocharging has been to increase power at low engine speed (Gruden & Richter 1984, Shahed 2003, Institut Français du Pétrole). Ambitious combined-cycle measures to save energy have been adopted in some heavy-duty engines, but not yet in automobiles. Finally, some improvement of τ is also feasible through insulating the cylinder walls; but in practice it probably cannot be increased much in that way.

In summary, while today's best gasoline engines achieve a thermodynamic efficiency of 38% and the best that could be done is much less than 100%, it is practical to improve automobile engines to

¹³ For discussion of health effects see Health Effects Institute website.

¹⁴ In a quiescent fuel-air mixture the flame goes out for fuel-air ratios less than about two-thirds stoichiometric. See discussion of flammability limits in combustion texts. Achieving very low nitrogen oxide emissions under these conditions is a major challenge for the technology.

roughly 45%. Lean burn is the main line of development, but there are other concepts which can even be combined with lean burn. The challenge for lean-burn technology is to meet emissions standards with room to spare, because those standards are in the process of being tightened.

Mechanical efficiency. The mechanical efficiency, η_m , accounts for the frictional losses in the engine. It is the ratio of work output by the engine to the net work by the gases on the pistons in the compression plus power strokes. See eq. (2a) and (2b). There are three engine frictions: 1) rubbing of metal parts, like piston rings on cylinder walls, 2) gaseous friction, especially at the throttle and valves, and 3) friction in the engine-accessories and their belt drives (Heywood 1988, chapter 13).

The mechanical efficiency averages some 50 to 55% in the composite US driving cycle, or about 45% if transmission losses are included. Instantaneous η_m is very sensitive to the kind of driving, near zero when the vehicle is coasting, braked or stopped, and high when the load is high. At moderate engine speed and near wide-open throttle η_m is about 85%. The power required in almost all driving is far below the engine's maximum capability in today's vehicles, and the resulting low η_m offers the easiest opportunity to increase fuel economy, as discussed below.

The key to understanding efficiency is to "model the losses", in this case the frictional work. A convenient notation is that of "mean effective pressure":

$$mep = 2000P/V \cdot N$$

Here P is power in kW averaged over an engine cycle, mep is in kPa, V is the engine displacement or the swept volume $V_{max} - V_{min}$ of each cylinder times the number of cylinders, in liters, and N is engine speed in rps. (The factor of 2000 is 2 from the number of revolutions per 4-stroke cycle times 1000 L/m³.) The reason for introducing mean effective pressures is that power roughly scales with engine size and speed; thus mean effective pressures are roughly the same for different engines and engine speeds.

The rate of frictional work in an internal combustion engine can thus be written:

$$P_{frict} = f_{mep} \cdot V \cdot N / 2000 \quad (5a)$$

where f_{mep} is "friction" mean effective pressure, cylinder pressure averaged over the full four-stroke cycle. Similarly, the output power can be written:

$$P_b = b_{mep} \cdot V \cdot N / 2000 \quad (5b)$$

where b_{mep} is "brake" mean effective pressure.

Measurements of the rate of fuel use by internal combustion engines show it to be essentially linear in the power output, except near wide open throttle (WOT).¹⁵ This is known as Willans' line (Roumegoux 1991, Ross 1994). An example of measurements supporting this linear dependence is shown in Fig. 5. Here the y-axis is the "fuel-equivalent" mean effective pressure which is defined as $(2000/VN)P_{fuel}$.

At normal engine speeds, a satisfactory approximation for friction in spark ignition engines is linear in bmep:

$$fmep = (fmep_0 - c \cdot bmep) \quad (6)$$

where $fmep_0$ is the friction mean effective pressure at no load. The negative bmep term is primarily associated with the throttling loss: The throttle varies from almost closed at low power, to wide open, so as the throttle valve is opened and power output increases, the frictional loss at the throttle declines.

Figure 5. Measured Fuel Rate vs Power, Volkswagen 1.8 Liter Engine

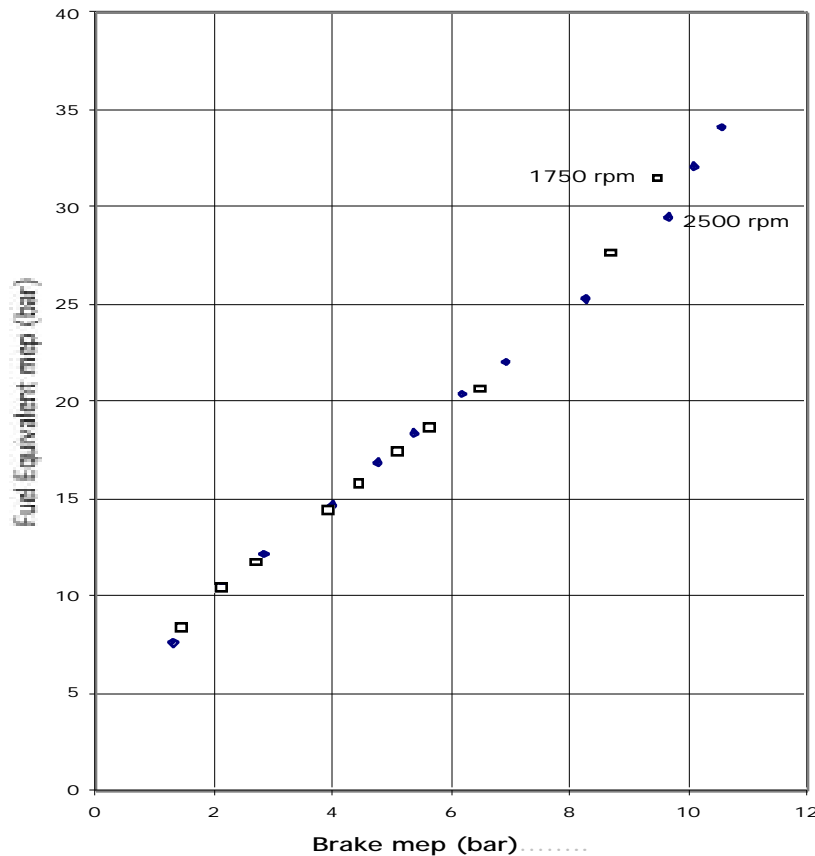

¹⁵ Fuel use increases faster near WOT because of the practice of injecting extra fuel, or making the mixture "rich", to improve performance and cool the components.

Here

$$c \cdot b_{\text{mep}_{\text{WOT}}} \quad 60 \text{ kPa}$$

the pressure drop into the inlet manifold at low power, a bit more than 1/2 atmosphere; and, for engines which do not compress the incoming air, $b_{\text{mep}_{\text{WOT}}} \quad 1000$ to 1200 kPa. The linear approximation for the fuel energy rate is then:

$$P_{\text{fuel}} = [f_{\text{mep}_0} + (1-c)b_{\text{mep}}] \cdot V \cdot N / (2000 \tau) \quad (7)$$

For good modern engines, typical values to use in eq(7) are:

$$f_{\text{mep}_0} \quad 160 \text{ kPa, and } \tau = 0.38$$

for engine speeds near 30 rps (and they are not sensitive to V or N). In the composite US driving cycle, excluding operations where no power is delivered to the wheels, the average $b_{\text{mep}} \quad 200$ kPa. (Note that it varies widely.) Thus a typical fuel-energy rate for a 2.0 L engine is:

$$P_{\text{fuel}} = (160 + 0.94 \cdot 200) 2 \cdot 30 / (0.38 \cdot 2000) = 27.5 \text{ kW, or}$$

$$P_{\text{fuel}} / \text{LHV} = 27.5 / 44 = 0.62 \text{ g/s of fuel}$$

Here LHV 44 kJ/g is the lower heating value of the gasoline. From eq(6) we also see that the dimensionless slope in plots of the form of Fig. 5 is $(1-c) / \tau \quad 2.5$.

Overall engine performance. The overall efficiency of the engine is:

$$\tau \cdot \eta = P_b / P_{\text{fuel}} \quad (8)$$

In a first approximation, the efficiency τ does not vary much from engine to engine or with operating point (Ferguson 1986, section 11.2); but f_{mep_0} increases with engine speed (Yagi et al. 1991; Heywood 1988 chapter 13) and increases somewhat for small engines (Ferguson 1986, section 11.1).

In Figure 6, a performance map is shown for a 2.7 L gasoline engine, showing the brake specific fuel consumption:

$$\text{bsfc} \quad (P_{\text{fuel}} / \text{LHV}) / P_b = 1 / (\tau \cdot \text{LHV}) \quad (9)$$

The brake specific fuel consumption is commonly expressed as grams of fuel consumed per kWh of output work. At the most efficient operating point in Fig. 6, $\text{bsfc} \quad 255$ g/kWh. The overall engine efficiency at that point is thus $= 3600 / (44 \cdot 255) = 32.1\%$.

Figure 6. Performance Map for a 2.7 Liter Spark Ignition Engine

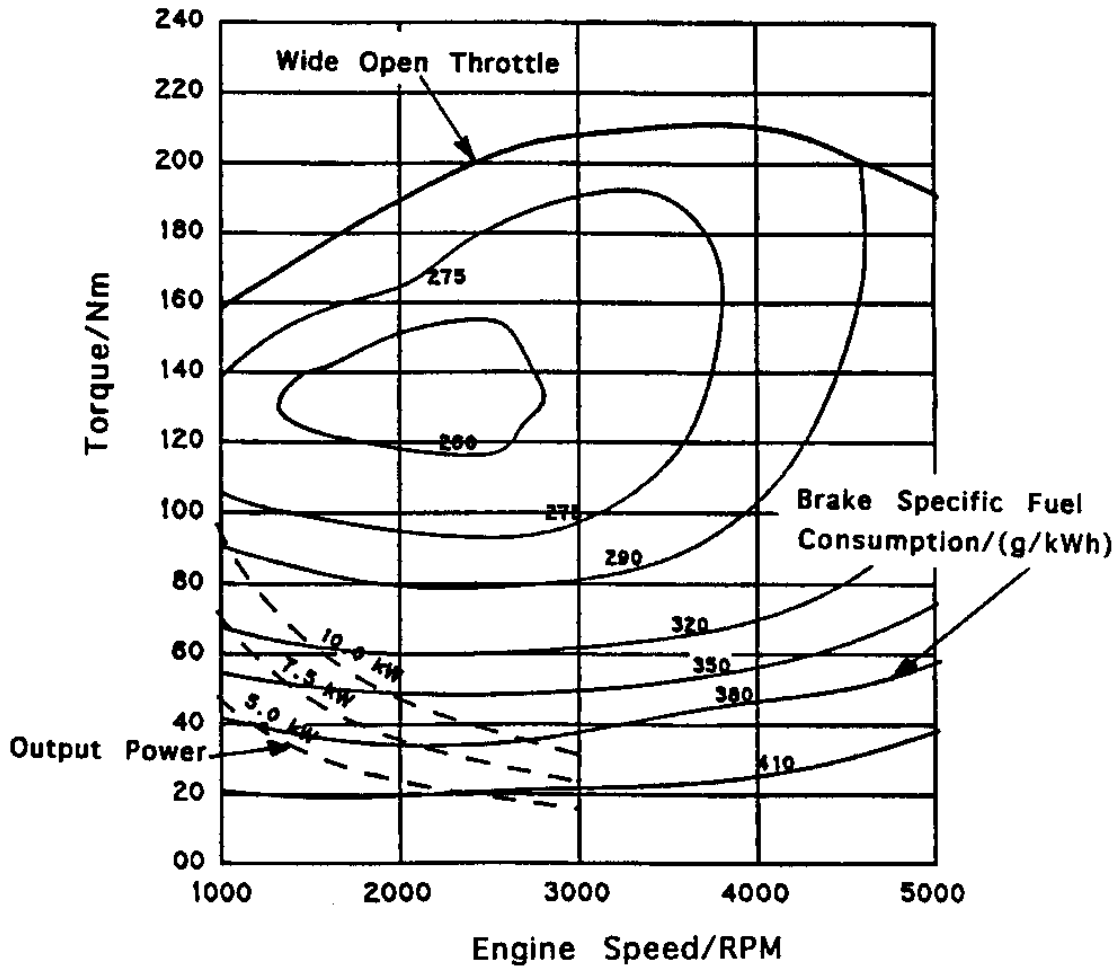

Let us instead estimate using the approximation eq(7), and the parameters just given. Take the operating point with maximum efficiency to be near 30 rps and $P_b/P_{WOT} = 0.74$:

$$= b_{mep} \cdot \tau / [f_{mep0} + (1-c)b_{mep}]$$

$$= 740 \cdot 0.38 / [160 + (1 - 0.06)740] = 32.9\%$$

which is in satisfactory agreement with the value from Fig. 6. At this operating point one also finds $m = 0.86$.

An engine's frictional work in a trip is roughly proportional to the total number of revolutions made by the engine during the trip and to the engine's displacement, based on the VN factor in eq(7). Turning the engine off when the wheels are not powered reduces the

engine-on time in the US urban driving cycle by almost 1/2 and the number of revolutions by about 20%. Adopting an engine with only half as much displacement reduces fmep by almost half. As we see below, with good design, such opportunities could enable major improvement in m with no or only minor sacrifice in performance.

A typical automobile's energy consumption. There are three ways to display the energy flows in vehicle operation (Table 1): 1) Overall viewpoint: one explicitly describes all the losses within the powertrain. 2) Work viewpoint: one explicitly describes all work done against friction, but one allocates the "lost work", or thermodynamic inefficiency, to the work categories. 3) Vehicle load viewpoint: one explicitly describes only the vehicle loads, allocating all the losses within the powertrain to the final loads.

TABLE 1. ESTIMATED USE OF FUEL ENERGY BY A TAURUS IN THE COMPOSITE US DRIVING CYCLE, FROM THREE VIEWPOINTS (based on 100 units of fuel energy consumed)

viewpoint→	overall	work	v.load
vehicle loads			
air drag	5	13	30
tyre rolling resistance	5	13	29
brakes	5	14	30
vehicle accessories	2	5	11
powertrain losses			
engine "lost work"	62	NA	NA
engine frictions	18	47	NA
transmission friction	3	8	NA
total	100	100	100

As shown in Table 1, the three major vehicle loads are comparable in the US composite driving cycle (load viewpoint - right column). (More realistically, in today's typical driving, speeds are higher and the air drag term would be larger.)

The overall powertrain losses are shown in the left-hand column of Table 1. The overall energy-efficiency, from fuel to wheels in average driving, is the sum of the vehicle loads, i.e. 17 units out of 100. This is essentially the product:

$$\langle t \cdot m \rangle \langle t \rangle \langle m \rangle \langle \rangle = 38\% \cdot 53\% \cdot 85\% = 17\% \quad (10)$$

Here $\langle \rangle$, the average automatic-transmission efficiency, is taken as 85%.¹⁶ One finds the overall 17% as the sum of the loads in the left-hand column of Table 1, and $\langle m \rangle = 45\%$ as the sum of the vehicle loads in the central column. The 17% average powertrain efficiency is powerful information. For example, it helps you to estimate how

¹⁶ Reasonable estimates of $\langle \rangle$ for urban and highway driving are 0.80 and 0.9, respectively. There is considerable variation; some analyses take $\langle \rangle$ to be about 80% in the composite cycle, with $\langle \rangle$ in urban driving about 0.65. Manual transmissions are about 90% efficient in most driving.

much more efficient an electric vehicle with the same vehicle load might be. That exercise is left to the reader.

The thermodynamic lost work in the engine is $100 - 38 = 62\%$. As shown in the overall perspective of Table 1, some 55% of the remaining energy is work against powertrain friction. Thus, the work against friction is $0.55 \cdot 0.38$ or 21% of the energy input, of which 18 points are engine friction and 3 transmission friction. This overall perspective is illustrated in Figure 7. However, since the lost work as a percentage is relatively difficult to change, the most interesting perspective may be that of the work viewpoint (middle column of Table 1).

Figure 7. Approximate Flows of Available Work: US Composite Driving Cycle

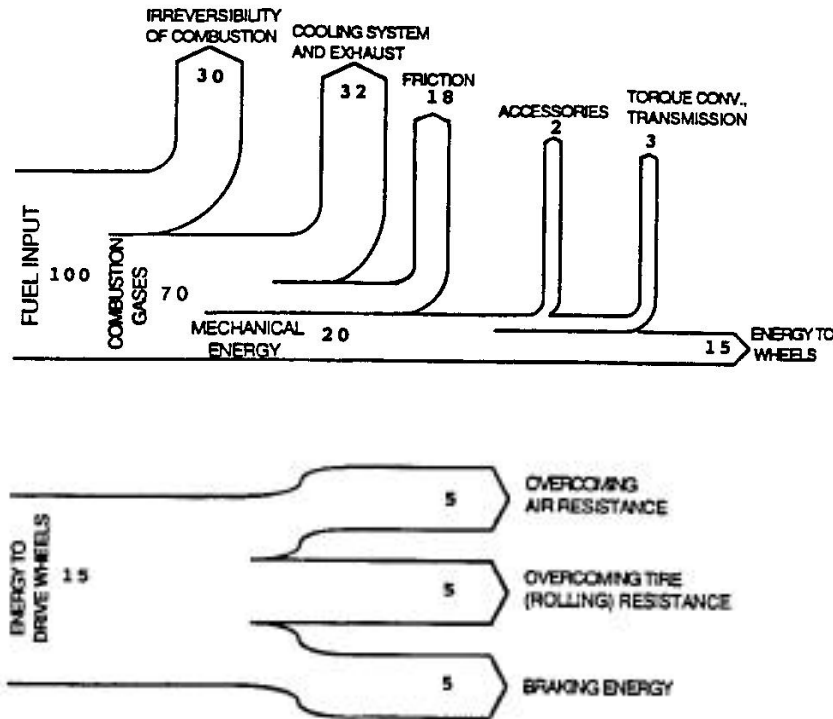

The reader who is interested can use the formalism, with the help of a few parameters, to calculate fuel use by various vehicles in various kinds of driving. Examples are carried through for constant-speed driving and driving in the US driving cycles in the Appendix.

Improving Mechanical Efficiency

As the work viewpoint in Table 1 shows, over half the fuel energy in the composite driving cycle is used to overcome friction within the engine and transmission. These losses could be greatly reduced through changes broadly characterized as design.

The Performance Challenges for New Designs. Before considering design of a more efficient car, however, let's review vehicle-performance characteristics which may interact with design choices. There are three important measures of driving performance characterized by times of minutes, a few seconds, and a fraction of a second:

The first is maximum sustained power - for minutes - the determinant of speed in a long hill climb. Substantially less power than that of today's engines would do for today's typical midsize car. For example, 50 kW would enable a midsize car to maintain 65 mph (105 km/h) up the 6% grade on the expressway west of Denver (Fig. 1 above). High speed on level ground, albeit not autobahn speed, is less of a challenge.

The second is maximum transient power - for several seconds - the determinant of acceleration capability in high-speed driving and of 0 to 100 km/h acceleration time. This is where the maximum power capability of today's cars of 100 kW or more comes in. For example, this power will accelerate a midsize car on level ground from 110 to 125 km/h in about 3 seconds.

The third is maximum torque, or, more particularly, power accessible within a small fraction of a second, *without an increase in engine speed*, where torque is related to power by $P = 2\pi N \tau / 1000$, with P in kW, N in rps and τ in N•m. This performance requirement concerns the strength of the powertrain's immediate response to the driver's signal for increased power. Wide open throttle torque at a normal engine speed of, say, 2000 rpm, is a good measure. High torque at normal N can be sensed immediately and is a major selling point for automobiles; it gives the feel of power, while the maximum transient power, achieved at high engine speed, may be less important.

I have briefly mentioned the opportunities to reduce the vehicle load and increase the thermodynamic efficiency. Reducing frictional losses in the powertrain is perhaps the largest and easiest opportunity to save fuel. Opportunities to increase η_m are: a) reducing or eliminating gaseous friction, i.e. reducing throttling, b) reducing friction through engine downsizing, c) reducing friction between rubbing parts and in engine accessories in other ways (not discussed here), d) turning the engine off when little power is needed, and e) reducing transmission friction, especially in automatics.

Control of power with less throttling. About one-quarter of the work against engine friction in spark-ignition engines is due to throttling; so reducing throttling is an important target. As mentioned above, simply varying the amount of fuel introduced into the cylinder is the means of power control in diesels. Unfortunately, this non-frictional technique cannot easily be adopted for spark-ignition engines, since combustion is unstable in highly lean mixtures. In the DISC engine mentioned above, however, the fuel-air

ratio can be varied enough to enable substantially reduced throttling. Without any throttling, friction mean effective pressure would be reduced from:

$$(f_{mep_0} - c_{b_{mep}}) \quad 158 \text{ to } (f_{mep_0} - c_{b_{mep_{WOT}}}) \quad 110 \text{ kPa}$$

The combined effect of lean-burn on thermodynamic efficiency and reduced throttling on mechanical efficiency could be a 25% increase in fuel economy in the composite US driving cycle (Nakamura et al. 1987).

A different innovative method of power control can be achieved with variable valve timing or VVT (Amann 1989, Amann & Ahmad 1993). Conventionally the valves are driven by cams with a fixed relation to crank angle. Instead of using the same valve opening and closing angles under all conditions, it is highly advantageous to use different timings at different levels of power and engine speed. Thus, VVT can increase power at wide open throttle as well as reducing the need for throttling at low power. (The latter is important for fuel economy over an urban cycle.) The variation can be realized by having alternate cams which can be moved into place, as is done in some production engines by Honda. Another VVT mechanism is electrical operation of the valves. Using solenoids, low energy valve operation becomes very effective - and appears feasible, (Schechter & Levin 1996) although not yet implemented in a production engine.

One way to control the amount of air with VVT is through the inlet valve opening time. The needed air is admitted (with open throttle), then the valve is shut early, and the rest of the compression stroke completed. With the valve closed, the compression is essentially elastic. In this way the control mechanism is changed from purely frictional to partly non-frictional. Dimmers of ordinary electric lights are analogous: Like a throttle, variable resistors were formerly used to dim electric lights. Now pulse-width modulation is used for dimming, meaning that the circuit is closed part of the time and open for the rest of each short cycle. This control method involves little resistive loss.

Friction reduction by engine downsizing. All three engine frictions (rubbing, gaseous and engine-accessory) are roughly proportional to displacement. The ratio of maximum power to displacement, or specific power, has been almost doubled in production engines over the past 20 years. And technological developments should enable this progress to continue. One can take advantage of increased specific power to downsize engines, i.e. to adopt smaller engines of the same power. There is a drawback. Some of the increase in specific power is achieved by increasing the power at given engine speed, but much is achieved by increasing the maximum engine speed. Use of high speed engines to achieve high power involves some compromise with fraction-of-a-second performance, because it takes a little time (about 1/2 second) to downshift and

speed up an engine to achieve high power. (See Fig. 8.) I wonder whether a 1/2 second delay represents a significant sacrifice.

Figure 8. Transmission Management with a Smaller Engine of the Same Power

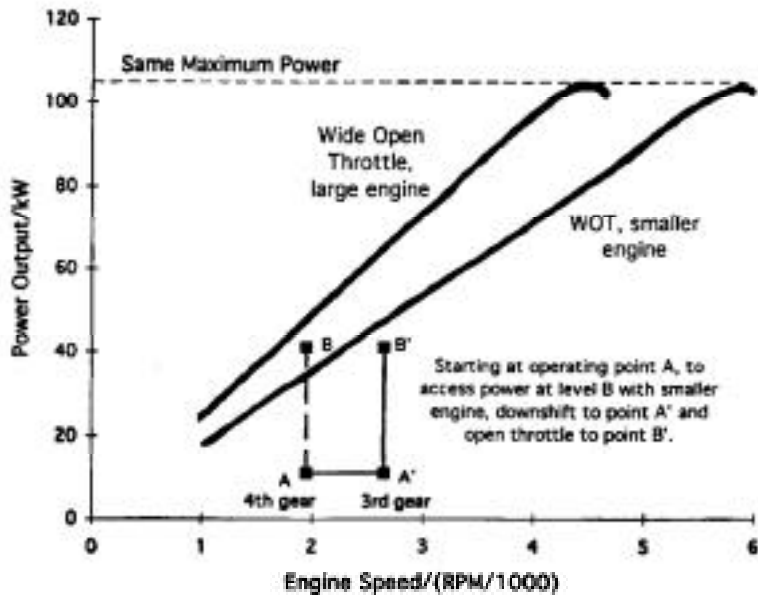

One technique that increases specific power is to increase the number of valves per cylinder, thus increasing the speed of gas intake and exhaust (Gruden & Richter 1984). Four valves per cylinder have been widely adopted in recent years. Another technique for increasing power at a given speed, long used in race cars, is to tune the manifolds. At a given engine speed, one can arrange to have a high-pressure wave arrive outside an inlet valve the moment it opens. Variable inlet "runners" are now being adopted in production vehicles.

Another technique, which has multiple benefits, is improved control of fuel injection, spark timing, and exhaust gas recirculation (an anti-pollution technique). The trend is to increase the number and sensitivity of microprocessor-based sensors and controls (Jurgen 1994). Sensors widely adopted in recent years include: air flow or pressure in the inlet manifold, oxygen in the exhaust, and knock. In addition, sensors of quantities such as in-cylinder pressure, pressure or temperature in the exhaust manifold, and rotational acceleration of the drive shaft, are being developed as part of an attempt to achieve full control of combustion *in each cylinder and each cycle*. The DISC engine, already introduced in Japan by Toyota and Mitsubishi, helps realize these control opportunities by injecting fuel directly into the cylinder each cycle. The scope for control is limited in present engines which inject fuel upstream from the inlet valves (Fig. 2), because much of the fuel condenses on the walls.

Yet another option is variable displacement, use of a small engine at low power and a large engine at high power. The most ambitious concept is to have independent engines on the same shaft, connected by clutches so that one or two or even three engines can be used depending on the power required. This concept is being developed by Knusaga, an engineering firm in Michigan. It is not efficient to use small cylinders, because of their high surface to volume ratio, so one is led to a two cylinder engine as the smallest unit. If vibrations can be reduced to a satisfactory level, this scheme could be attractive.

Hybrid powertrains. A hybrid vehicle supplements the tank of fuel and engine with a second energy system: a different kind of energy-conversion device with its own storage. The hybrids in production involve electric motors with corresponding electrical storage, in addition to the fuel tank and internal combustion engine. The storage technologies are batteries and electric capacitors. Other hybrids in research and development use hydraulic motors and hydraulic accumulators (tanks with a compressible fluid under pressure). And there are other options. With two energy systems on board, a variety of powertrains and management schemes are possible. I will only discuss hybrids where all the energy on board originates in the fuel tank, designs near to today's conventional vehicles (Burke 1995).

There are three energy advantages with a hybrid: 1) Braking, normally achieved through friction, can be achieved in part by regeneration, absorbing the vehicle's kinetic energy into the electromechanical storage. For example, an electric drive motor doubles as a generator and can charge batteries during braking. Regenerative braking is emphasized in the 2004 Toyota Prius hybrid. 2) The motor can drive the vehicle and its accessories without the engine when power requirements are low. As shown above, engine friction dominates at low power; and, although motors and their controllers also are lossy at low power, they are much less so than an IC engine. Volkswagen pioneered turning the engine off in deceleration and vehicle stop (Seiffert & Walzer 1991). (Vehicle accessories, other than an air conditioner, are run from the battery.) The VW technology works smoothly in a small diesel-powered production vehicle. When I rode in it, I found the automatic engine start and stop barely noticeable. As engine controls are improved, a smooth restart with low emissions could be achieved in any vehicle. 3) With the presence of electromechanical storage and motor the IC engine can be downsized and adequate power will be available in almost all driving situations.

As indicated below, a rough doubling of fuel economy is possible with hybrid powertrains, but exactly how much will be practical, and at what cost, is somewhat uncertain. The great variety of hybrid concepts, both in components and management schemes, opens up major research opportunities.

Reduced transmission friction. Transmissions play a critical energy role by determining the operating point of the engine (Stone

1989, chapter 4). To reduce the role of engine friction in normal driving, one wants the transmission to call for operation at low engine speed and near wide open throttle; but when extra power is needed, one wants a rapid and smooth shift to high engine speed. In practice, many cars with small engines and automatic transmissions already operate in something like this mode. (See Figure 8.) In addition to downshifting fairly rapidly when high engine speed is needed for power, automatic transmissions smooth the acceleration at low vehicle speed. To achieve this kind of control, a torque converter is used. It is a fluid (frictional) coupling.

A technology widely adopted in recent years to improve fuel economy is torque converter lock up. With lock up, the coupling is fixed by clutches in cruise driving. When acceleration is wanted, the clutches are released and the fluid coupling comes into play. Another technology towards which designers are moving is additional forward gears. In lowest gear, the gear ratio is essentially fixed by considerations of starting the vehicle on an up grade (Stone 1989). Then, using convenient steps, one finds that with four forward gears the ratio is still fairly high at high vehicle speed, so that engine speeds are higher than desirable for fuel economy at, say, 115 km/h or 70 mph. Thus one wants the "span" of gear ratios to be large. Five forward speeds are essential for manuals, and six speeds desirable, and designers are beginning to create 5-speed and 6-speed automatics.

Continuously variable transmissions are also being developed, and are in use in some small cars. They can offer less friction than automatics while smoothing accelerations. Otherwise, they may not have much fuel economy benefit relative to five or six speed gearing, but may offer other advantages. For example, they might enable use of a constant-speed engine or motor.

The most exciting of recent developments is the dual clutch transmission. In a transmission with six forward gears two shafts each carry three gears. One shaft has a gear connected to the power, the other is idling, but is ready almost instantly to be moved into the line of power. The shift is quick and almost unnoticeable.

Conclusions

If you have concluded that propulsion based on the old internal-combustion engine is in state of flux, with a bewildering array of good options to make it better, you're right. Rough estimates of the practical opportunities for improved fuel economy for conventional automobiles and a near-conventional hybrid are outlined in Table 4.

These improvements are based on *technologies presently in use*, while some of the technologies discussed above are still under development. The improvements shown in Table 2 would bring τ to almost 44% and average m^* , from 45 to perhaps 70% for an advanced hybrid like the 2004 Prius.

TABLE 2. ESTIMATES OF THE FACTOR BY WHICH COMPOSITE FUEL ECONOMY CAN BE IMPROVED WITH CURRENT TECHNOLOGIES

	Conventional Vehicle (a)	Diesel Hybrid (b)
thermodynamic efficiency factor	1.15	1.15
mechanical efficiency factor (engine and transmission)	1.20	1.50
regenerative load reduction factor(c)	NA	0.90
OVERALL POWERTRAIN EFFICIENCY	1.38	1.92
vehicle-load factor(c)	0.73	0.80
OVERALL FUEL ECONOMY IMPROVEMENT FACTOR	1.89	2.40

a) US style midsize car, DeCicco & Ross 1993

b) same car with 1.9 litre DI diesel and shallow cycling of battery-based supplementary system

c) The reciprocal enters in the overall fuel economy.

The prospect for widespread adoption of vehicles incorporating improvements such as those assumed in Table 2 is poor in the US at this time in part because the price of petroleum fuels is very low, inhibiting private sector initiatives. Indeed, while many efficiency technologies have been introduced in recent years, they have been used to increase power and weight at fixed fuel economy. Moreover, in the US there has been a resurgence of faith in perfect markets, what I call simple economics, inhibiting the creation of public policies to stimulate technical change that would help meet environmental goals.

This discussion has focused on more-or-less conventional vehicles. The existing investment in factories, service facilities, vehicles, and, most important, people is so great that there is considerable momentum toward further refining the present kind of vehicle. Nevertheless, there are also major initiatives for new fuels, new kinds of propulsion, and new vehicle structures.

The improvement in mechanical efficiency from 45% to 68%, shown in Table 2 for the composite US driving cycle, would take advantage of most of the practical opportunity associated with friction reduction. As noted, however, τ could be substantially increased beyond the 38•1.15 44% of Table 2 by developing and adopting fuel cells instead of combustion engines (Williams 1993). Fuel-cell vehicles with hydrogen as the fuel are under development, but it may

be a long time before they are for sale (American Physical Society March 2004 http://www.aps.org/public_affairs/index.cfm). Moreover, as mentioned above, the vehicle load might be reduced much more than indicated in the table. Extremely-high fuel economy cars have been discussed by Lovins in the context of deep weight reduction (Lovins 1993). Research is needed on lightweight materials, e.g. to bring their costs down, and on the safety and drivability of very light general-purpose cars.

Finally, I have a claim about research opportunities: All areas of science/technology with important social implications, including those that may appear mundane, offer surprisingly varied, interesting and accessible opportunities for research.

Acknowledgments I thank several people for teaching me about automotive engines, and reviewers of this journal for their suggestions on this paper. I particularly want to thank my students Feng An and Wei Wu for sharing the research activities with me.

APPENDIX: APPLYING THE FORMALISM

Consider a typical "midsize" US vehicle, the 1995 Ford Taurus with 3.0 L engine and automatic transmission; some characteristics are shown in Table A1. The fuel economies in the US urban and highway driving cycles are also shown. Taurus is a large car to most people outside the US and even to many inside it. Smaller cars are not so different from an energy perspective, however, *if their design is not focused on fuel economy*. Compare, for example, Volkswagen Golf with a two litre gasoline engine and 5-speed manual transmission, with the Taurus. The curb weights are 1169 and 1509 kg, respectively; the volumes of their passenger compartments are 88 and 102 cubic feet, respectively; and the US composite fuel economies correspond to 7.4 and 8.6 L/100km, respectively. In terms of this measure of fuel economy, the Golf is 16% more efficient.

TABLE A1. CHARACTERISTICS OF THE STANDARD 1995 FORD TAURUS(a)

	traditional units	metric units
load characteristics		
weight(curb + 300 lbs.)	3418 lbs.	1.55 tonnes
drag coefficient	0.33	0.33
frontal area	22.9 ft ²	2.12 m ²
rolling resistance coeff.	0.009	0.009
powertrain		
displacement	182 cu. inch	3.0 litre
maximum power	140 hp@4800rpm	104 kW
maximum torque	165 ft.lbs.@3250rpm	224 Nm
fuel economy(b)		
urban cycle	22.2 mpg(c)	10.6 L/100km
highway cycle	38.5 mpg	6.1 L/100km
composite cycle	27.4 mpg	8.6 L/100km

a) Some are estimates.

- b) for the US driving cycles, unadjusted for actual driving. For the composite cycle, combine 55% urban and 45% highway cycle fuel-distances ratios.
 c) miles per US gallon

With the parameters from Table A1, readers can do their own fuel use calculations for particular kinds of driving. For fuel referred to in US regulations, one can use the energy density 120 MJ/US gallon or 31.7 MJ/litre. Some fuel use calculations for these cycles and for cruise driving have been presented (Ross 1994, An and Ross 1993). Let us calculate the fuel use in steady driving at a speed of 100 km/h = 27.8 m/s. Use eq(7) in the form:

$$P_{\text{fuel}} = [f_{\text{mep}_0} \cdot V \cdot N / 2000 + (1-c)P_b] / \tau$$

To find P_b , one calculates P_{load} from eq(3). For Taurus:

$$P_{\text{tyres}} / = 0.009 \cdot 1.55 \cdot 9.8 \cdot 27.8 / 0.9 = 4.22 \text{ kW}$$

$$P_{\text{air}} / = 0.6 \cdot 0.33 \cdot 2.12 \cdot 27.8^3 / (1000 \cdot 0.9) = 10.02 \text{ kW}$$

So, assuming $P_{\text{access}} = 0.75 \text{ kW}$, $P_b = 15.0 \text{ kW}$. To find N , one can adopt approximations where typical engine speeds depend only on engine displacement, not on details of the driving:

$$N_{\text{pwr}} = 30(V/3)^{-0.3} \text{ and } N_{\text{unp}} = (15 - V) \text{ rps}$$

where V is in litres and the subscripts refer to two driving modes: powered and unpowered. The latter I define as no power at the wheels, or vehicle stop, coasting and braking.¹⁷ Obviously these expressions for N are strong simplifications. For the example under consideration, then, $N = 30 \text{ rps}$. Numerically, we find:

$$P_{\text{fuel}} = [160 \cdot 3 \cdot 30 / 2000 + (1-0.06)15.0] / 0.38 = 56.1 \text{ kW, or}$$

$$56.1 \text{ kW} \cdot 3600 \text{ s/h} / (31.7 \text{ MJ/L} \cdot 100 \text{ km/h}) = 6.4 \text{ L/100km.}$$

The first term in the expression for P_{fuel} in kW is essentially the frictional work inside the engine; and it is 7 kW, not a small rate!

Carry out the same calculation for Golf with a 2.0 L engine. We need the inertial weight. Take it to be 300 lbs, or 136 kg, plus the curb weight; so for the Golf it is 1305 kg. We need frontal area A ; an approximation for contemporary non-US cars is $0.81(\text{width} \cdot \text{height})$, which is 1.96 m^2 for Golf. According to another approximation just given, the engine speed is 33.9 rps. Guess that $P_{\text{access}} = 0.5 \text{ kW}$. Although one is not likely to know the other parameters specific to this car, the point is that they (rolling resistance coefficient, drag coefficient, f_{mep_0} , c , transmission efficiency, and

¹⁷ In high speed driving $\langle N \rangle_{\text{pwr}}$ is higher and increases more rapidly with decreasing engine displacement than suggested here.

thermodynamic efficiency) are roughly the same for all such cars. Thus one finds:

$$P_{\text{tyres}}/ = 3.56, P_{\text{air}}/ = 9.26, \text{ and } P_{\text{fuel}} = 45.6 \text{ kW},$$

corresponding to 5.2 L/100km, or 23% more energy efficient at 100 km/h than the Taurus.

As a second example, let us calculate fuel use over the US driving cycles. The way to handle decelerations is to consider energy conservation: the powertrain output over the entire trip is the sum of energy for tyres, air and accessories, and the energy ending in the brakes rather than in inertial change. Rewrite and approximate eq(7) for the average rate of fuel use for a trip or driving cycle:

$$\langle P_{\text{fuel}} \rangle = \left\{ \langle \text{fmep}_0 \rangle (\langle N \rangle_p T_p + \langle N \rangle_u T_u) V / 2000 + (1-c) \langle P_b \rangle \right\} / \langle t \rangle \quad (\text{A1})$$

Here subscripts p and u designate powered (beyond for accessories) and unpowered driving, respectively; T_x is the fraction of time spent in each of these modes, with $T_p + T_u = 1$. In addition, the P_b term can also be decomposed into the kinds of work done, using eqs(3) and (2c), to obtain the separate items in Table 1.

The main difficulty is estimating air and brake terms over a varying driving pattern. The straightforward method is to obtain the second-by-second sequence of vehicle speeds and calculate the power levels at each second. I express the results in terms of P_{air} and the kinetic energy evaluated at the overall average trip speed $\langle v \rangle$, because we found some general approximations in that form (which I won't discuss). Thus (An & Ross 1993b):

$$\langle P_{\text{air}} \rangle = P_{\text{air}}(\langle v \rangle), \quad \langle P_{\text{brakes}} \rangle = \langle v \rangle n_s \cdot 0.5 M^* \langle v \rangle^2$$

where n_s is the number of stops per m, and M^* was mentioned in connection with eq(3). Values are given for the two US cycles in Table A2.

TABLE A2. CHARACTERISTICS OF TWO US DRIVING CYCLES

	Urban (UDC)	Highway (HDC)
$\langle v \rangle$	8.74 m/s	21.6 m/s
T_p	0.55	0.90
'	2.87	1.11
'	2.24	1.94
n_s	1.50 per km	0.061 per km

Some intermediate stages in the calculation for Taurus are given in Table A3. Here the friction term is the entire left hand expression within the brackets of eq(A1); and the three $\langle P_b \rangle$ terms are actually of the form $(1-c) \langle P_{\text{tyres}} \rangle / _$ and so on; and where $_$ is taken to be 0.8 for UDC and 0.9 for HDC. I have included a factor

for the effect of cold start in increasing engine friction. To find P_{fuel} one adds the terms, including the P_{access} term without transmission loss, and divides by $\langle t \rangle$.

TABLE A3. STEPS IN CALCULATING TAURUS FUEL ECONOMY (kW)

	tyres	$\langle P_b \rangle$ terms ^b air	brakes	engine friction ^a	$\langle P_{fuel} \rangle$
UDC	1.40	0.94	2.11	5.67	28.5
HDC	3.08	4.90	0.99	6.77	43.3

a) Includes a cold start factor of 1.07, for the UDC only.

b) in the form $(1-c)\langle P_{tyres} \rangle /$, etc.

The fuel economies are then $100\langle P_{fuel} \rangle / (31.7\langle v \rangle) = 10.3$ and 6.3 L/100km in the US urban and highway cycles, respectively (or 22.9 and 37.2 miles per US gallon), in reasonable agreement with the measured values in Table A1. In this exercise, although some major approximations were made, the most significant quantities may be accurate within a factor of (1 ± 0.05) .

REFERENCES

- AIP, *Efficient Use of Energy*, Walter Carnahan et al., Eds., American Institute of Physics Conference Proceedings No. 25, part I, 1975.
- Amann, C. A., "The Automotive Engine -- a Future Perspective," Society of Automotive Engineers 891666, 1989.
- Amann, C. A., & T. Ahmad, "Automotive Propulsion Systems," in *Encyclopedia of Applied Physics*, George L. Trigg, Ed., American Institute of Physics, VCH Publishers, New York, 1991-.
- An, Feng, and Marc Ross, "A Model of Fuel Economy with Applications to Driving Cycles and Traffic Management", Transportation Research Record No. 1416, 105-114, Transportation Research Board, National Research Council, 1993a.
- An, Feng, and Marc Ross 1993b, "A Model of Fuel Economy and Driving Patterns," Society of Automotive Engineers 930328, Warrendale, PA.
- Burke, Andrew, "Hybrid Vehicles" in *Encyclopedia of Energy Technology and the Environment*, A. Bisio & S. G. Boots, Eds., Wiley Interscience, 1995.
- Calvert, J. G., J. B. Heywood, R. F. Sawyer and J. H. Seinfeld, "Achieving Acceptable Air Quality: Some Reflections on Controlling Vehicle Emissions", *Science* **261**, 37-45, 1993.
- DeCicco, John, and Marc Ross, "An Updated Assessment of the Near-Term Potential for Improving Automotive Fuel Economy", American Council for an Energy-Efficient Economy, Washington, DC, 1993.

Ferguson, Colin R., *Internal Combustion Engines: Applied Thermosciences*, John Wiley, 1986.

Gillespie, Thomas D., *Fundamentals of Vehicle Dynamics*, Society of Automotive Engineers, 1992.

Gruden, D., & H. Richter, "Torque Characteristics and Fuel Efficiency of Various Gasoline Engine Concepts", Society of Automotive Engineers, 841284, 1984.

Heavenrich, Robert, & Karl Hellman 1996, "Light-Duty Automotive Technology and Fuel Economy Trends Through 1996", US Environmental Protection Agency, Ann Arbor MI.

Heywood, John B., *Internal Combustion Engine Fundamentals*, McGraw-Hill Book Co., 1988.

Kartha, Sivan, & Patrick Grimes, "Fuel Cells: Energy Conversion for the Next Century," *Physics Today* 47, p 54, Nov. 1994.

Lovins, A. B., J. W. Barnett and L. H. Lovins, "Supercars: The Coming Light-Vehicle Revolution," Rocky Mountain Institute, Snowmass CO, 1993.

Jurgen, Ronald, *Automotive Electronics Handbook*, McGraw-Hill Book Co., 1994.

Keenan, Joseph H., *Thermodynamics*, John Wiley & Sons, 1948.

Lumsden, Grant, David Eddleston & Richard Sykes, "Comparing Lean Burn and EGR", Society of Automotive Engineers, Warrendale, PA, 970505, 1997.

Muranaka, Shigeo, Yasuo Tagaki & Tokuhei Ishida, "Factors Limiting the Improvement of Thermal Efficiency of S.I. Engine at Higher Compression Ratio," Society of Automotive Engineers, Warrendale, PA, 870548, 1987.

Nakamura, Hirokazu, Hikoichi Motoyama & Yuhiko Kiyota, "Passenger Car Engines for the 21st Century", Society of Automotive Engineers, Warrendale, PA, 911908, 1991.

Ross, Marc, *Automobile Fuel Consumption and Emissions: Effects of Vehicle and Driving Characteristics*, *Annual Review of Energy and Environment* 19, 1994.

Ross, Marc, Robert Goodwin, Rick Watkins, Michael Q. Wang and Tom Wenzel, *Real-World Emissions from Model-Year 1993, 2000 and 2010 Passenger Cars*, Physics Dept., University of Michigan, Ann Arbor MI, report available from American Council for an Energy-Efficient Economy, Washington DC, 1995.

- Roumegoux, J. P., "Fuel Conservation: Road Transport", in M. Papgeorgiou, Ed., *Concise Encyclopedia of Traffic and Transportation Systems*, Pergamon Press, Oxford, pp 173-179, 1991.
- Schechter, Michael M., and Michael B. Levin, "Camless Engine", Society of Automotive Engineers, Warrendale, PA, 960581, 1996.
- Seiffert, Ulrich, & Peter Walzer, *Automobile Technology of the Future*, Society of Automotive Engineers, Warrendale, PA, 1991.
- Shahed, S. M., "Gasoline Engine Boosting and Downsizing for CO2 Emission Reduction"
ftp://ftp.arb.ca.gov/carbis/cc/techsem/final_presentations/shahed_gas_downsize.pdf CARB International Vehicle Technology Symposium, 2003.
- Stone, Richard, *Automobile Fuel Economy*, Macmillan Education, London, 1989.
- Stone, Richard, *Introduction to Internal Combustion Engines, 2nd edition*, Macmillan Publishers, London, 1992.
- Taylor, Charles Fayette, *The Internal Combustion Engine in Theory and Practice*, 2nd ed. revised, MIT Press, Cambridge Mass. 1985.
- Williams, Robert H., "Fuel Cells, Their Fuels, and the US Automobile", World Car Conference, CE-CERT, University of California Riverside, 1993.
- Yagi, Shizuo et al., "Estimate of Total Engine Loss and Engine Output in Four Stroke S.I. Engines", Society of Automotive Engineers, Warrendale, PA, 910347, 1991.
- Zemansky, M. W., & R. H. Dittman, *Heat and Thermodynamics, 6th ed.*, McGraw-Hill Books, New York, 1981.