

Mechatronics II Laboratory

Lab 2: Dynamometer I: Force/Torque Sensors

Introduction

This is the first of two labs. You will use your results from the force measurement setup from this lab to construct a dynamometer in the next lab. With this dynamometer, you will measure the torque-speed characteristics of a DC motor. If you are careful and take your time with this part of the lab, then your next lab will run much more smoothly.

Force Sensors

Neither force nor torque is measured directly. Typically engineers measure the deformation or strain of some material and then the force or torque required to produce the deformation in that material is inferred from this measurement. The deformation can be measured in many ways. If the displacement is large, as with a spring, the displacement can be read directly on a scale or linear potentiometer. If the displacement is smaller, a Linear Variable Differential Transformer (LVDT), encoder, or other sensitive displacement measuring transducer can be used. If the deformation is very small, strain gages can be applied to the surface of the deformed material.

In this laboratory experiment you will use strain gages to measure the strain placed on a cantilever beam that is undergoing transverse deflection as a result of force applied to the beam. Your main objective will be to calibrate the system as a force sensor. The beam is clamped on one end, making it cantilevered, and strain gages are applied to this end in order to read the strain at this location. You will deform the beam by placing known weights on the free end, thus deflecting the beam and creating strain. The force exerted by the weights is proportional to the strain along the beam. This strain will be measured using strain gauges in a Wheatstone bridge configuration. You will calibrate the output of the strain gages as a function of the applied force. From this calibration, the measurements taken from the strain gages can be converted via a least-squares-fit to a linear approximation of the applied force.

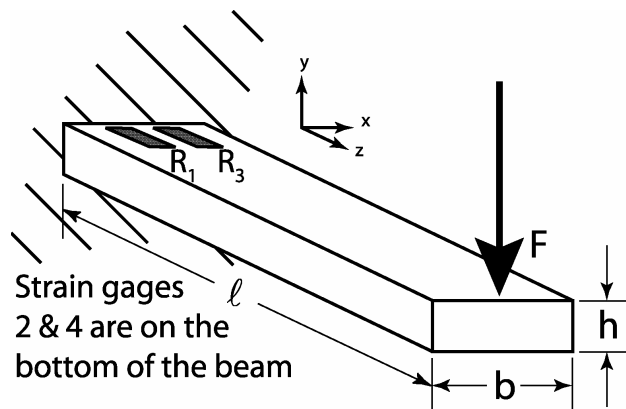

Figure 1: Cantilever beam with strain gauges attached.

Strain Gauges

A bonded metal foil strain gage is a variable resistor whose change in resistance is proportional to the strain in the material upon which it is mounted. To obtain accurate results, the gage must be well adhered to the surface of the material and the gage's grid is properly aligned with the direction of the deformation. A common configuration to measure the force exerted on a cantilever beam utilizes four gages (see Figure 1). The dimensions of the beam of Figure 1 are ℓ , b , and h representing its length width and height respectively. A point force of magnitude F is applied to the free end of the beam in the $-y$ direction. Two gages are mounted on the bottom of a beam, and two on the top. They are wired together to form a Wheatstone bridge circuit, which provides maximum sensitivity to very slight changes in resistance. The Wheatstone bridge circuit used in this lab is depicted in Figure 2 on the next page.

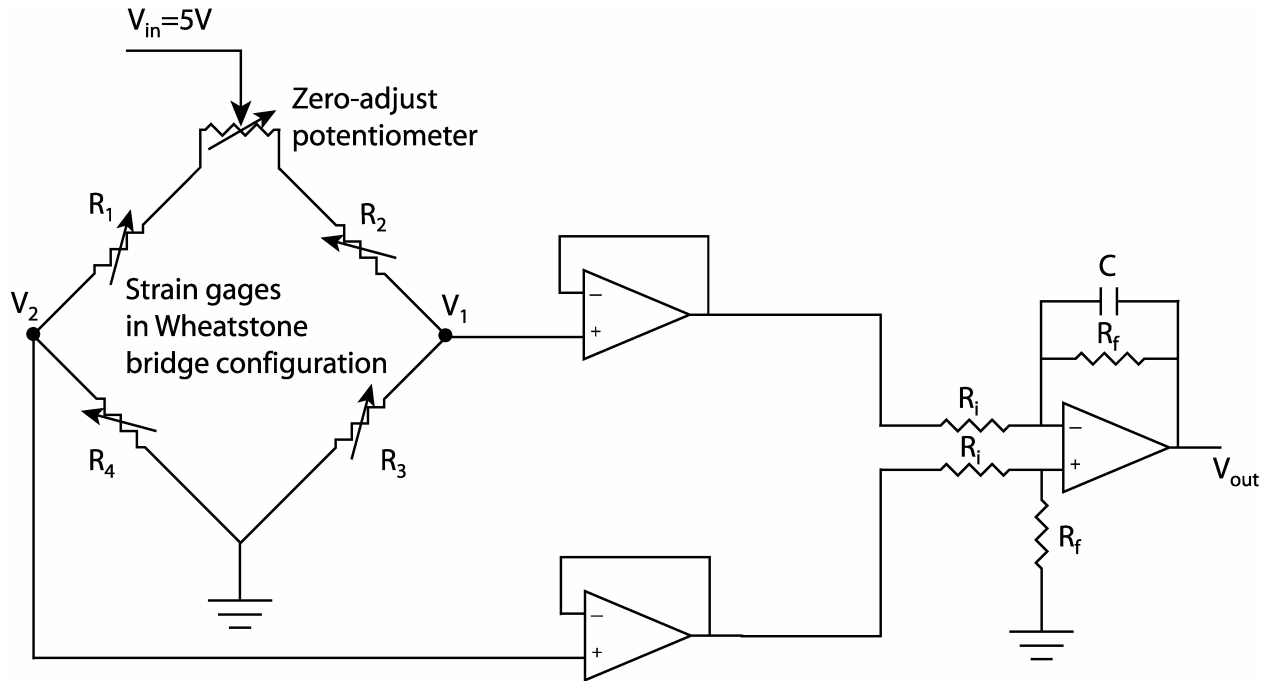

Figure 2: Wheatstone bridge amplification circuit

The zero-adjust potentiometer is included in the circuit so that, when no load is applied to the beam, the user can manually adjust V_1 and V_2 until their voltages are equal (balancing the bridge). The Wheatstone bridge creates a voltage divider. The voltage V_1 can be determined using the voltage divider law as follows:

$$V_1 = V_{in} \frac{R_3}{R_2 + R_3} \quad (1)$$

Similarly, the voltage V_2 is

$$V_2 = V_{in} \frac{R_4}{R_1 + R_4} \quad (2)$$

The difference between V_2 and V_1 gives a highly sensitive and accurate measurement of the strain experienced by the beam at the location of the strain gages. The voltage that corresponds to this strain, V_ϵ is:

$$V_\epsilon = V_2 - V_1 = V_{in} \left(\frac{R_4}{R_1 + R_4} - \frac{R_3}{R_2 + R_3} \right) \quad (3)$$

Assuming that the strain gages are all similar, when the bridge is balanced and there is no load applied to the end of the beam $R_1 = R_2 = R_3 = R_4 = R$. When a load is applied to the beam in the $-y$ direction, strain gages 1 and 3 experience tension when a force is applied, and gages 2 and 4 experience compression. The resistance of any particular strain gage changes by ΔR as its surface area increases ($+\Delta R$, tension) or decreases ($-\Delta R$, compression): i.e. $\Delta R_1 = -\Delta R_2 = \Delta R_3 = -\Delta R_4 = \Delta R$. After the force is applied to the beam, equation (3) becomes

$$\begin{aligned} V_\epsilon &= V_{in} \left(\frac{R + \Delta R}{(R + \Delta R) + (R - \Delta R)} - \frac{R - \Delta R}{(R - \Delta R) + (R + \Delta R)} \right) \\ &= V_{in} \left(\frac{\Delta R}{R} \right) \end{aligned} \quad (4)$$

The simplified relationship of Equation 4 above reveals a linear relationship between V_ε and ΔR .

The op-amp circuit on the right of Figure 1 consists of two buffers and a differential amplifier. The differential amplifier has two jobs: it subtracts one signal from another, and it amplifies this difference according to the following relationship:

$$V_{out} = \frac{R_f}{R_i} (V_2 - V_1) \quad (5)$$

Combining Equations 3 and 5 yields the following relation:

$$V_{out} = \frac{R_f}{R_i} V_\varepsilon \quad (6)$$

Note that the capacitor used in the circuit is not included in the expression for V_{out} . This capacitor can be ignored because the signal coming from the Wheatstone bridge is nearly a DC signal (i.e. the voltage change is nearly zero) and in DC analyses a capacitor is an open circuit.

Mechanical Strain

The strain gages mounted on the cantilevered beam measure strain, a mechanical parameter. Mechanical strain ε is defined as the change in length $\Delta\ell$ per unit length ℓ of a material under loading conditions: in mathematical terms:

$$\varepsilon = \frac{\Delta\ell}{\ell} \quad (7)$$

Note that strain is a unitless quantity, but units such as in/in are commonly used. Mechanical stress σ is defined as the amount of force per unit area experienced by a material at any given point within the material. If the strain in the material is small, Hooke's law relates stress and strain for linear springs, where the spring constant is Young's modulus, also known as the modulus of elasticity. This stress-strain relationship is as follows:

$$\sigma = \varepsilon E \quad (8)$$

The units of Young's modulus are the same as that for stress. The stress in the cross-section of a beam can be determined using Euler's beam equation

$$\sigma = \frac{Mc}{I} \quad (9)$$

where M is the moment experienced at the point in question ($M=F\ell$), c is the distance from the midline of the material ($c=h/2$) to the point of interest along the height of the beam, and I is the area moment of inertia, which, for a beam of rectangular cross-section, can be determined using the following relation:

$$I = \frac{bh^3}{12} \quad (10)$$

Upon substitution and reduction of Equations 7 through 10, the theoretical strain of a rectangular cantilevered beam experiencing small deflections is defined by the following equation:

$$\varepsilon = \frac{6F\ell}{bh^3E} \quad (11)$$

Of all the parameters on the right-hand side of Equation 11, only F is not a constant. Thus Equation 11 expresses the linear relationship between the applied force and the resulting strain in the beam.

7. Plot the data you just collected on the grid provided. Using a straightedge and your best judgment, draw a best-fit line through the data. Measure the slope of the line - rise over run - and find the y-intercept.

Slope: _____ N/V

Intercept: _____ N

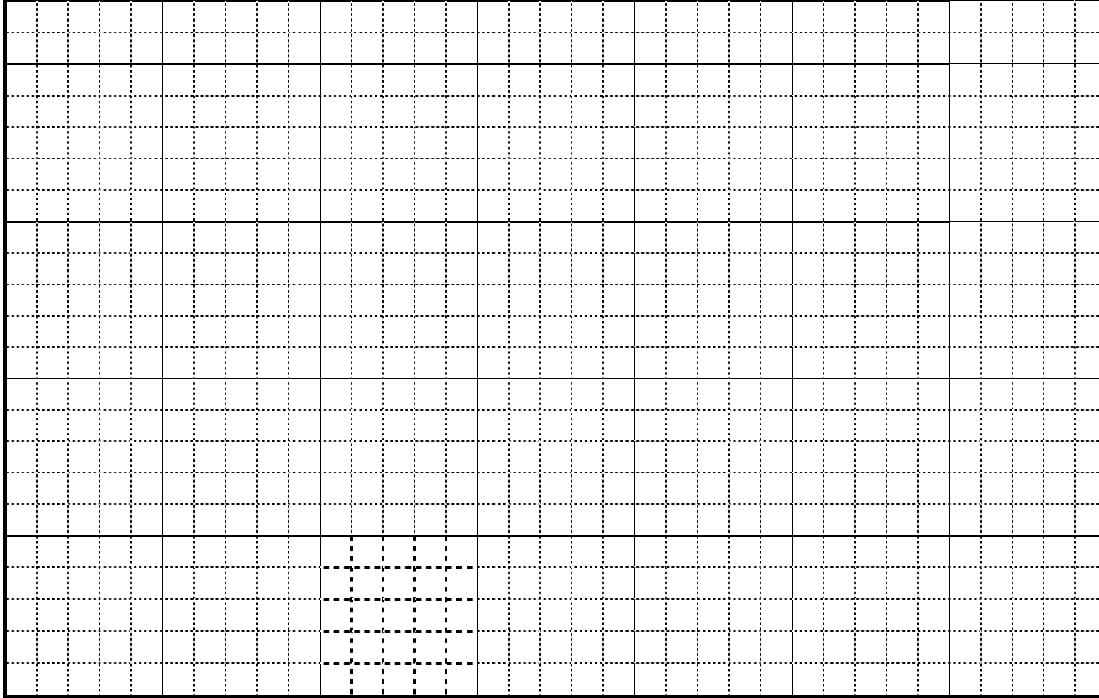

8. Use the least squares method (also known as linear regression) to obtain the best first-order relationship between the Force/Voltage Data. As you may recall, the least squares fit of a data set to a line can be obtained by (the bar over a variable indicates the average of that variable):

$$y = a_1x + a_0, \text{ where}$$

$$a_1 = \frac{n\sum x_i y_i - \sum x_i \sum y_i}{n\sum x_i^2 - (\sum x_i)^2}, \text{ and}$$

$$a_0 = \bar{y} - a_1 \bar{x}$$

$$a_1 = m = \text{_____ N/V}$$

$$a_0 = b = \text{_____ V}$$

9. Use a plotting application, such as Excel or Matlab, to plot your data set and calculate the equation for the best-fit line and compare it to your results from steps 3 and 4. Record the results below.

$$m = \text{_____ N/V}$$

$$b = \text{_____ V}$$

$$R^2 = \text{_____}$$

10. Measure the distance between the center of the strain gages and the contact point of the force on the beam.

Given this distance, calculate the torque calibration coefficient: _____ T/V

