

Rotary Sensors



Single Phase Output Type

■ Features

1. Sensing over wide range of rotation speed including a complete halt.
2. Compact package and light weight.
3. Simple installation by easy adjusting of a signal output and gap distance.
4. Best suited for harsh environments.

■ Applications

1. Rotation speed detection of Factory Automation equipment.
2. Rotation position detection.
3. Proximity Switch.

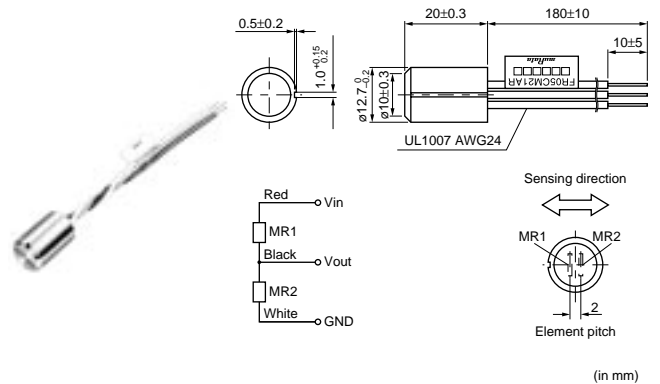

Part Number	Supply Voltage (V)	Output Voltage (Vp-p)	Total Resistance (k ohm)	Response Frequency (kHz)	Operating Temperature (°C)	Target Gear Module	Phase Difference
FR05CM21AR	5	0.5 min.(at 25°C,Gap=0.2mm)	0.7 to 1.5	0 to 100	-10 to 70	0.3 to 1.0	Single

■ Output Wave Form

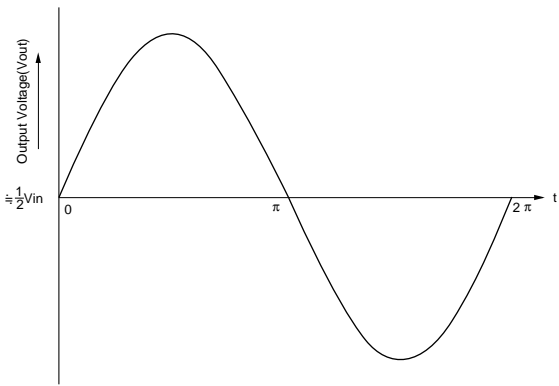

Rotary Sensors



Dual Phase Output Type

2

■ Features

1. By monitoring the phase shift direction the gear rotation direction can be detected.
2. Wide sensing range from high speed to a complete halt.
3. Good Signal-to-Noise ratio ; high resolution ; high sensitivity.

■ Applications

1. Detection of gear rotation speed and direction in Factory Automation equipment.
2. Detection of the direction of Linear motion servo.
3. Motor controller for vehicles.
4. Measuring the needle position in industrial knitting machine.

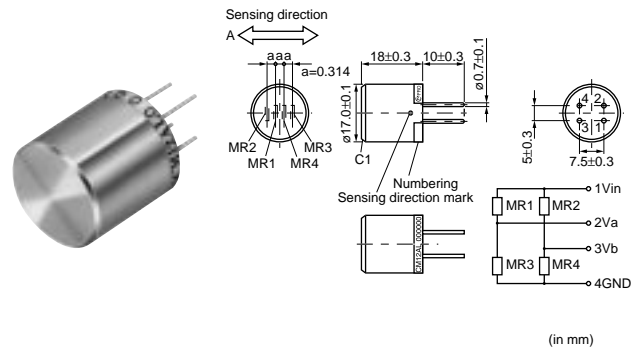

Part Number	Supply Voltage (V)	Output Voltage (Vp-p)	Total Resistance (k ohm)	Response Frequency (kHz)	Operating Temperature (°C)	Target Gear Module	Phase Difference
FR05CM12AL	5	0.45 min.(at 25°C,Gap=0.15mm)	0.2 to 1.0	0 to 100	-10 to 80	0.4	90deg. +/-5deg.

■ Output Wave Form

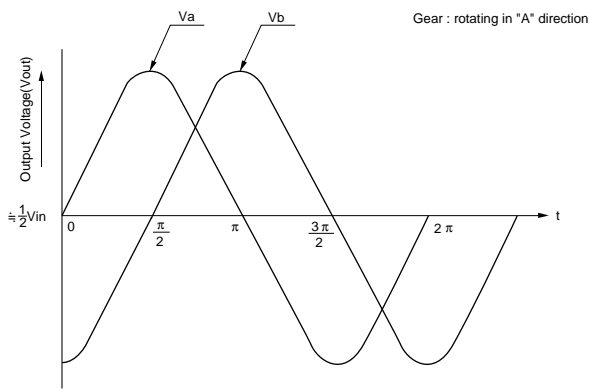

Rotary Sensors



Dual Phase, Digital Output Type

■ Features

1. Dual digital output.
2. LED indicators, for quick status check.
3. Easy mounting and connection.

■ Applications

1. Servo controller for linear motion of NC machine.
2. Controller for robot arm.
3. Controller for injection speed of moulding machine.

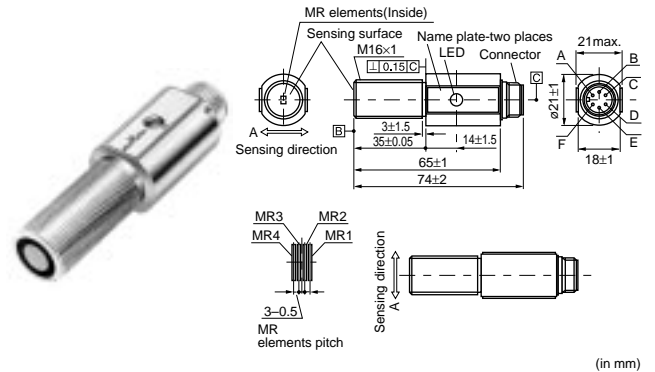

Part Number	Supply Voltage (V)	Output Voltage (V)	Total Resistance (k ohm)	Response Frequency (kHz)	Operating Temperature (°C)	Target Gear Module	Phase Difference
FR12AM32AC	12 +/-2V	Low Level=0.5 max.(at 25°C,Gap=max.0.3mm) High Level=4.5 min.(at 25°C,Gap=max.0.3mm)	297 to 363	0 to 20	-10 to 70	0.635	90deg./+/-40deg.

Supply Current:100mA max.

■ Output Wave Form

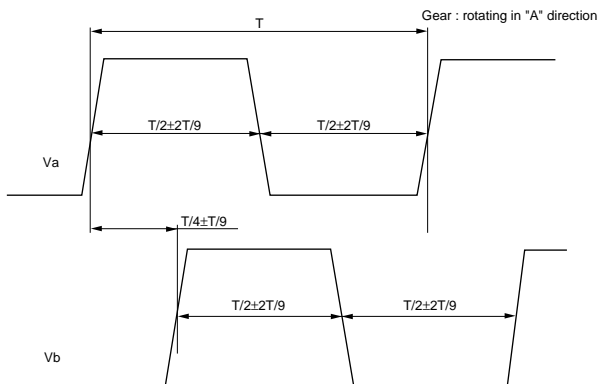

■ Block Diagram

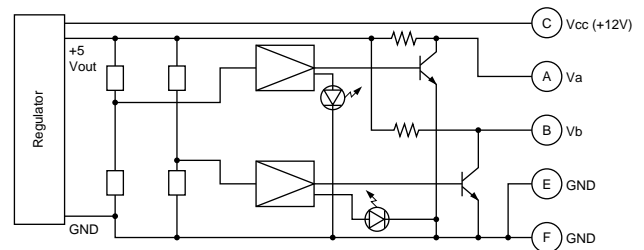

■ LED Indicator

Output	Va	High	Low	Low	High
	Vb	High	High	Low	Low
LED Color		Off	Red	Orange	Green

Rotary Sensors



Quad with Index Phase Type

■ Features

1. Higher signal level and higher common-mode noise rejection with a differential amplifier.
2. Index phase Z to locate the home position of the gear.
3. Compact package for easy mounting.
4. Anticorrosive stainless steel case.

■ Applications

AC servo motor controller for NC machine.

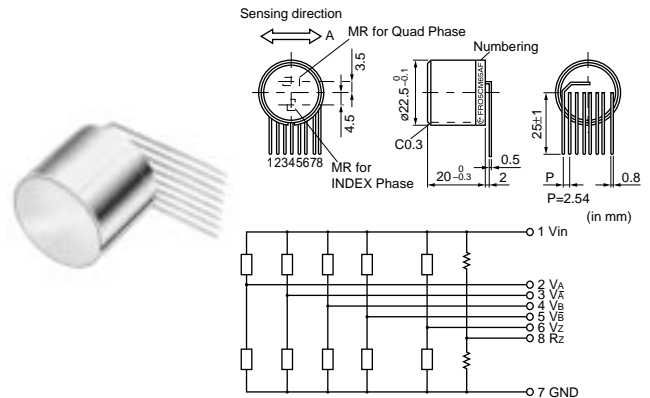

4

Part Number	Supply Voltage (V)	Output Voltage (Vp-p)	Total Resistance (k ohm)	Response Frequency (kHz)	Operating Temperature (°C)	Target Gear Module	Phase Difference
FR05CM65AF	5	0.3 min.(Phase:A-B,at 25°C,Gap=max.0.3mm) 0.6 min.(Phase:Z,at 25°C,Gap=max.0.3mm)	0.1 to 1.0	0 to 100	-10 to 80	0.4 (Phase:A-B)	90deg. +/-5deg. (Phase:A-B)

■ Output Wave Form

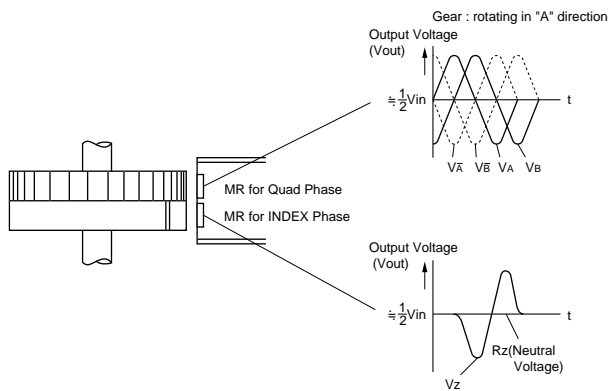

■ Phase Difference

Phase	Phase Difference (deg.)
A-B	90±5
A- \bar{A}	180±10
B- \bar{B}	180±10

Reference Data

■ Features

1. FR sensor consists of semiconductive magnetoresistors and a permanent magnet.
2. FR sensor detects the position and the speed of a gear over a wide range of frequency including a complete halt.
3. Non-contact sensing mechanism guarantees a long life.
4. Rugged and reliable, suitable for motor control for Factory Automation.
5. A variety of applications is possible with multiphase type.

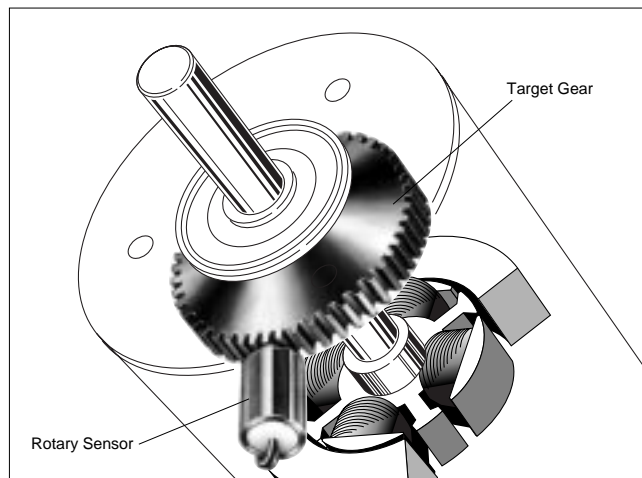

■ Magnetoresistive Effect

A change in the resistance of a ferromagnetic or semiconductive material when it is subjected to magnetic flux. Used in Murata's sensor is InSb which exhibits very high magnetoresistive effect in Fig. 1.

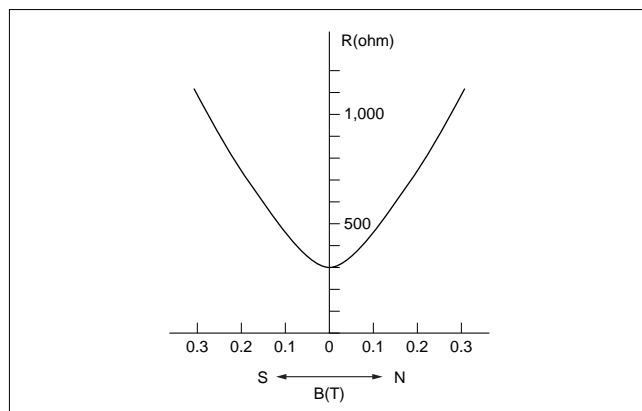

Fig. 1

■ Principle of Operation

As a magnetic material moves over the sensing surface, the magnetic flux distribution across the magnetoresistors varies.

This causes MR element resistance change and produces output signal as indicated in Fig. 2.

Therefore, when it is placed close to the magnetic gear as shown in Fig. 3, the sensor output a signal synchronized to gear rotation.

The count of signal's peaks is equal to the number of gear teeth passing over the sensor.

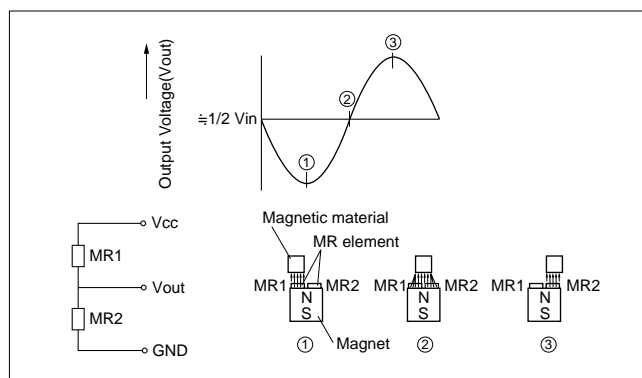

Fig. 2

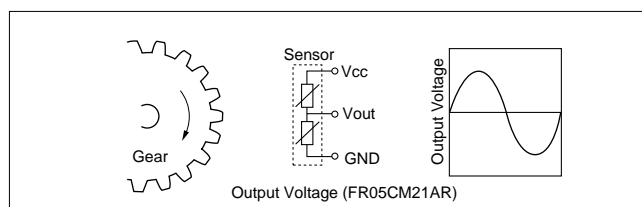

Fig. 3

Reference Data

Temperature Characteristics

Output signal, V_{p-p} is dependant on the ambient temperature.

Output voltage decreases as the temperature increases.

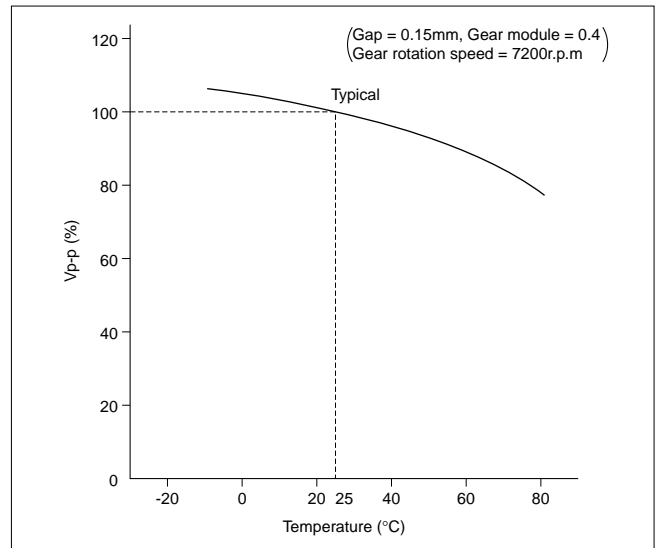

Fig. 4

Gap Characteristics

Larger signal are obtained when FR sensor is installed closer to the target gear.

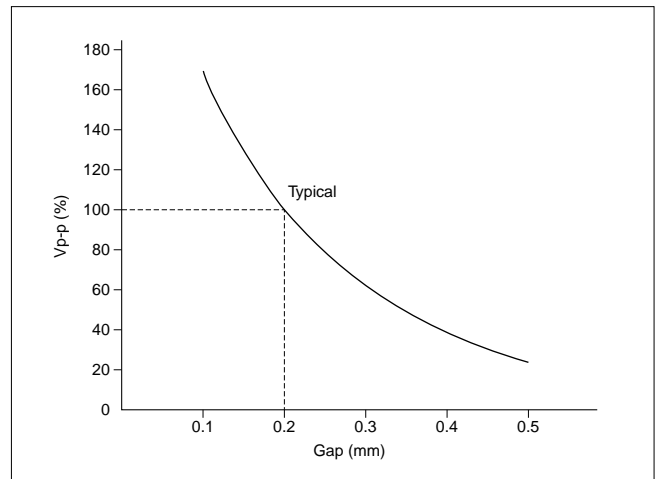

Fig. 5

Typical Application

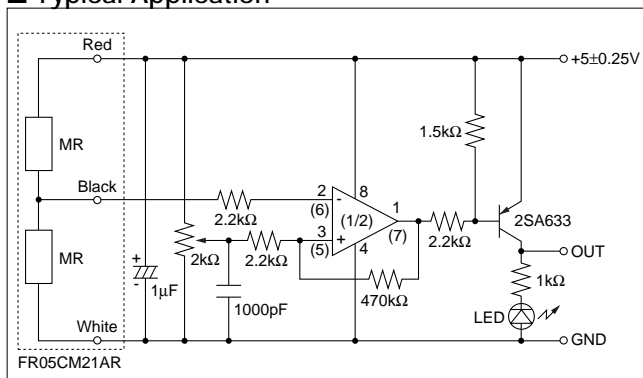

Fig. 6

Application Table

Part Number	Output Type	Motion		Gear Module	Gear Pitch (mm)
		Rotational	Linear		
FR05CM21AR	Single	△	○	M=0.3 to 1.0	P=0.9 to 4.0
FR05CM12AL	Dual	○	△	M=0.4	P=1.3
FR12AM32AC	Dual, Digital	△	○	M=0.635	P=2.0
FR05CM65AF	Quad with index	○	△	M=0.4	P=1.3

○: Best suited, △: Suitable

⚠Caution/Notice

■ ⚠Caution (Handling)

1. This sensor generates very strong suction because the sensor contains a permanent magnet. Be careful of handling the sensor not to apply mechanical shock.
2. Because this sensor contains a permanent magnet, it could damage magnetic signal in the writable magnetic card such as train ticket and pre-paid card. Please consult with us before applying it in such circumstances.
3. Do not approach the sensor to the person who is with an electronic medical device. It is very dangerous by miss operation of an electronic medical device.

■ Notice (Storage and Operating Condition)

1. Please do not apply mechanical shock or pressure on the sensing surface because it leads to change in the output level or destruction of magnetoresistive element.
2. Please do not use or keep the sensor in the corrosive gas (Chlorine gas, Nitric oxide gas, Sulfuric acid gas, and so on). Metal case might be corroded due to it. Some of our sensor is made with stainless steel case for better resistance to corrosion. If the sensor should be used in such an

environment, please consult with us.

3. Please do not apply excessive force to the terminal, not to rotate nor to bend.
4. Please do not pull the lead by excessive force, not to rotate, not to bend.
5. Please avoid the airborne particles.
6. Please avoid the strong vibration and shock.
7. Ambient temperature change should be within 1 degrees C/min.

■ Notice (Soldering and Mounting)

1. Wiring should be avoided while supply voltage is applied.
2. Do not place the sensor near high voltage lines or high current lines.
3. Please avoid placing magnetic material or magnetic field generator other than the detected object near to the sensor. It could cause change in the output level, resulting in malfunction of the finished goods.
4. Hand soldering should be applied. Soldering should

be done in following condition;

Soldering temperature:

350+/-10 degrees C less than 3 seconds or
260+/-5 degrees C less than 10 seconds.

5. Flux should be rosin flux and its chlorine content should be no more than 0.2wt%.
6. Flux cleaning should be done by hand brushing.
7. Prevent the flux cleaning solvent from splashing on the sensor.

● Part Numbering (The structure of the "Global Part Numbers" that have been adopted since June 2001 and the meaning of each code are described herein.)
If you have any questions about details, inquire at your usual Murata sales office or distributor.

Rotary Sensors

(Global Part Number) **FR** **05CM** **12AL**

① ② ③ ④

- ① Product ID
- ② Type
- ③ Characteristics
- ④ Individual Specification Code

* Global Part Number shows only an example which might be different from actual part number.

* Any other definitions than "① Product ID" might have different digit number from actual Global Part Number.

⚠ Note:

1. Export Control

⟨For customers outside Japan⟩

Murata products should not be used or sold for use in the development, production, stockpiling or utilization of any conventional weapons or mass-destructive weapons (nuclear weapons, chemical or biological weapons, or missiles), or any other weapons.

⟨For customers in Japan⟩

For products which are controlled items subject to the "Foreign Exchange and Foreign Trade Law" of Japan, the export license specified by the law is required for export.

2. Please contact our sales representatives or product engineers before using our products listed in this catalog for the applications listed below which require especially high reliability for the prevention of defects which might directly cause damage to the third party's life, body or property, or when intending to use one of our products for other applications than specified in this catalog.

- | | |
|-----------------------------|---|
| ① Aircraft equipment | ② Aerospace equipment |
| ③ Undersea equipment | ④ Power plant equipment |
| ⑤ Medical equipment | ⑥ Transportation equipment (vehicles, trains, ships, etc.) |
| ⑦ Traffic signal equipment | ⑧ Disaster prevention / crime prevention equipment |
| ⑨ Data-processing equipment | ⑩ Application of similar complexity and/or reliability requirements to the applications listed in the above |

3. Product specifications in this catalog are as of January 2002. They are subject to change or our products in it may be discontinued without advance notice. Please check with our sales representatives or product engineers before ordering. If there are any questions, please contact our sales representatives or product engineers.

4. Please read rating and ⚠CAUTION (for storage and operating, rating, soldering and mounting, handling) in this catalog to prevent smoking and/or burning, etc.

5. This catalog has only typical specifications because there is no space for detailed specifications. Therefore, please approve our product specification or transact the approval sheet for product specification before ordering.

6. Please read CAUTION and Notice in this catalog for safety. This catalog has only typical specifications. Therefore you are requested to approve our product specification or to transact the approval sheet for product specification, before ordering.

7. Please note that unless otherwise specified, we shall assume no responsibility whatsoever for any conflict or dispute that may occur in connection with the effect of our and/or third party's intellectual property rights and other related rights in consideration of your using our products and/or information described or contained in our catalogs. In this connection, no representation shall be made to the effect that any third parties are authorized to use the rights mentioned above under licenses without our consent.

8. No ozone depleting substances (ODS) under the Montreal Protocol are used in our manufacturing process.