

Humanoid Robot HRP-2

Kenji KANEKO ^{*1}, Fumio KANEHIRO ^{*1}, Shuuji KAJITA ^{*1}, Hirohisa HIRUKAWA ^{*1},
Toshikazu KAWASAKI ^{*2}, Masaru HIRATA ^{*2}, Kazuhiko AKACHI ^{*2}, and Takakatsu ISOZUMI ^{*2}

*1: National Institute of Advanced Industrial Science and Technology
1-1-1 Umezono, Tsukuba, Ibaraki 305-8568, Japan

*2: Kawada Industries, Inc.
122-1 Hagadai, Haga-machi, Haga-gun, Tochigi 321-3325, Japan

E-mail: {k.kaneko, f.kanehiro, s.kajita, hiro.hirukawa}@aist.go.jp,
{toshikazu.Kawasaki, m.hirata, kazuhiko.akachi, taka.isoizumi}@kawada.co.jp

Abstract

A development of humanoid robot HRP-2 is presented in this paper. HRP-2 is a humanoid robotics platform, which we developed in phase two of HRP. HRP was a humanoid robotics project, which had run by the Ministry of Economy, Trade and Industry (METI) of Japan from 1998FY to 2002FY for five years. The ability of the biped locomotion of HRP-2 is improved so that HRP-2 can cope with uneven surface, can walk at two third level of human speed, and can walk on a narrow path. The ability of whole body motion of HRP-2 is also improved so that HRP-2 can get up by a humanoid robot's own self if HRP-2 tips over safely. In this paper, the appearance design, the mechanisms, the electrical systems, specifications, and features upgraded from its prototype are also introduced.

1. Introduction

This paper presents a development of humanoid robot HRP-2 shown in Figure 1.

The traditional robots are typically used for factory automation and play in environments that are separated from the sphere of human lives and activities. However, the need for robots has recently been changed from factory automation to human friendly robot system. Coming the increasingly aging societies, robots that assist human activities in human daily environments such as in offices, homes and hospitals are expected. Especially, an emergence of humanoid robots is strongly expected because of anthropomorphism, friendly design, applicability of locomotion, behavior within the human living environments, and so on. To meet these demands, several humanoid robots have been developed in these years.

H6 and H7 are humanoid robots constructed by University of Tokyo [1]. H6 is 1370 [mm] height and 590 [mm] width respectively, and has a total of 35 D.O.F. Its weight is 55 [kg], since aircraft technologies were applied to the body frame, which led to a strong and light structure. H6 and H7 can walk up and down 25 [cm] high steps and can also recognize pre-entered human faces.

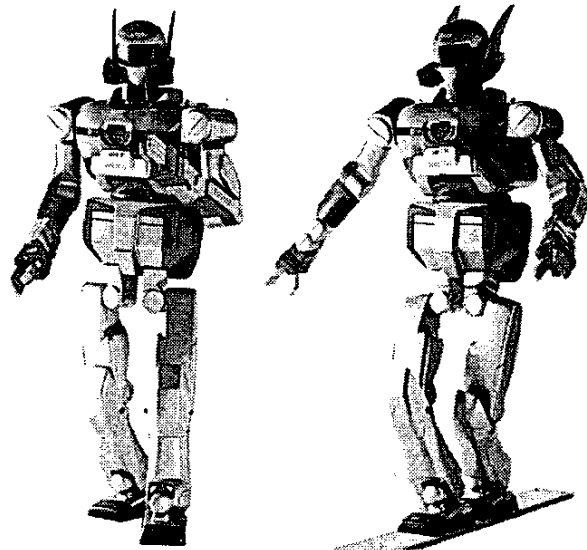

Figure 1. Humanoid Robot HRP-2

JOHNNIE is an anthropomorphic autonomous biped robot constructed by Technical University of Munich for realization of dynamically three-dimensional walking and jogging motion [2]. JOHNNIE with 17 D.O.F. is about 1800 [mm] height and about 40 [kg] weight respectively, while the operating power is supplied by external sources. Currently, a stable walking could be realized with up to 2.0 [km/h] [3].

SDR-3X (Sony Dream Robot-3X) is a compact size humanoid robot [4]. Its specifications are 500 [mm] height, 220 [mm] width, 5 [kg] weight, and 24 D.O.F. The reason Sony made SDR-3X as small as possible is that the smaller it is, the lower the cost becomes. In 2003, the latest SDR: SDR-4XII (580 [mm] height, 270 [mm] width, 7 [kg] weight with 38 D.O.F.), which is the enhanced version of SDR-4X [5], was announced. Presently its name was changed into QRIO (Quest for cuRIOsity). QRIO can more than just walk around such as squatting, getting up, and doing synchronized choreography. As an entertainment robot that lives with you, makes life fun, and makes you happy, QRIO would be on the market in the near future.

The most impressive humanoid robots should be HONDA humanoid robots. When the second prototype HONDA humanoid robot: P2 (1820 [mm] height, 600 [mm] width, 210 [kg] weight with 30 D.O.F.) was revealed in 1996 after ten years secret research, the robotics world was stunned. P2 is the world's first cable-less humanoid robot, which can walk and can go up/down stairs [6]. In 2000, downsizing P2 and P3 [7], ASIMO (1200 [mm] height, 450 [mm] width, 52 [kg] weight with 26 D.O.F.) appeared with a new walking technology (i-WALK) [8]. The introduction of i-WALK technology allowed ASIMO to walk continuously while changing directions, and gave the robot even greater stability in response to sudden movements. The newest impression of HONDA humanoids is that ASIMO Type-R, which is a Research Model of ASIMO and is children-size as well as a normal ASIMO, demonstrated 3.0 [km/h] walk at the robot exhibition: ROBODEX2003. It is no exaggeration to say that the great success of HONDA humanoid robot makes the current research on the world's humanoid robot to become very active area.

The more humanoid robots which can walk and can go up/down stairs are developed, the more humanoid robots are expected to perform several application tasks in an actual human living environment. However the application area of humanoid robots has still limited to the amusement and the entertainment.

For research and development of humanoid robot performing application tasks, the Ministry of Economy, Trade and Industry (METI) of Japan had run Humanoid Robotics Project (HRP for short) from 1998FY to 2002FY [9]. The final goal of HRP is to create 'useful' humanoid robots. Towards the goal, HRP have developed a humanoid robot called HRP-2 that can walk, lie down and get up. We believe that HRP-2 and its prototype HRP-2P [10] are the first humanoid robots that have the human-size, can lie down, and can get up.

This paper presents a development of HRP-2, which we developed in phase two of HRP (from 2000FY to 2002FY). In this paper, the appearance design, the mechanisms, the electrical systems, specifications, and features upgraded from its prototype are also introduced.

2. Specifications of HRP-2

The design concepts of HRP-2 are light, compact, but performable for application tasks like cooperative works in the open air shown in Figure 2 [11]. As a result, HRP-2 is designed to be feminine size.

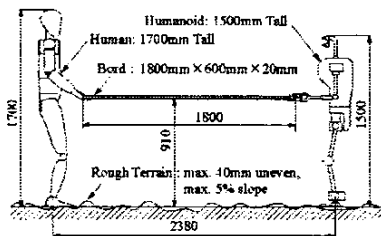

Figure 2. Cooperation Works in the Open Air

Figure 3 shows the mechanical configuration of HRP-2.

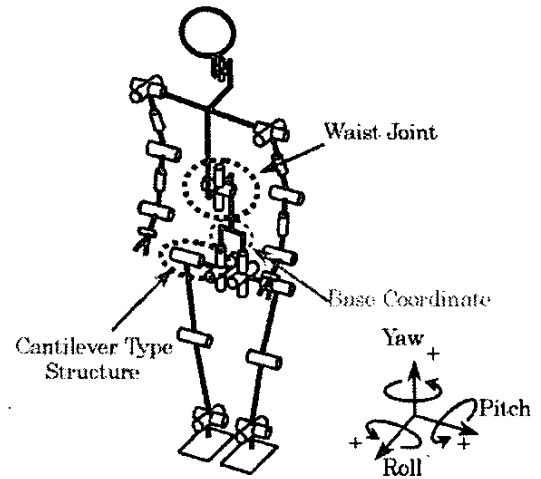

Figure 3. Configuration of HRP-2

As shown in Figure 3, HRP-2 inherits a mechanical configuration from its prototype HRP-2P. One of unique configurations is that the hip joint of HRP-2 has a cantilever type structure. The other is that HRP-2 has a waist with 2 D.O.F. The reason we designed so will be explained later.

Table 1 shows the principal specifications of HRP-2.

Table 1. Principal Specifications of HRP-2

| | | |
|-----------------------|-----------------|--------------------|
| Dimensions | Height | 1,539 [mm] |
| | Width | 621 [mm] |
| | Depth | 355 [mm] |
| Weight inc. batteries | | 58 [kg] |
| D.O.F. | Total 30 D.O.F. | |
| | Head | 2 D.O.F. |
| | Arm | 2 Arms × 6 D.O.F. |
| | Hand | 2 Hands × 1 D.O.F. |
| | Waist | 2 D.O.F. |
| Leg | | 2 Legs × 6 D.O.F. |
| Walking Speed | | up to 2.5 [km/h] |

Looking at Figure 1 and Table 1, we can observe that the light and compact humanoid robot was completed. The height, weight, and DOF of HRP-2 are the almost same as the HRP-2P. The following features have been upgraded in HRP-2.

I. Friendliness Upgrade:

External appearance was designed by a mechanical animation designer to make a human feel friendly for HRP-2.

II. Performance Upgrade:

Cooling systems incorporated in the leg actuators allow enhanced continuous walking endurance. Feet are re-designed for a high stiff structure. Links and axial stiffness are significantly upgraded to improve walking motion and operational performance.

III. Reliability Upgrade:

Electrical device noise was reduced to improve system reliability. Cooling systems were installed in both computer and actuator drive systems to improve temperature control.

IV. Compact-size Upgrade:

Electrical harnesses were made into ICs and specially designed battery units were developed to make the torso even more compact.

The details of designs are presented in the followings sections.

3. Appearance Design

To make a human feel friendly for HRP-2, an external appearance of HRP-2 was designed by Mr. Yutaka IZUBUCHI, who is a mechanical animation designer famous for his robots that appear in Japanese anime, including the well-known "Pat labor (stands for Patrol Labor)".

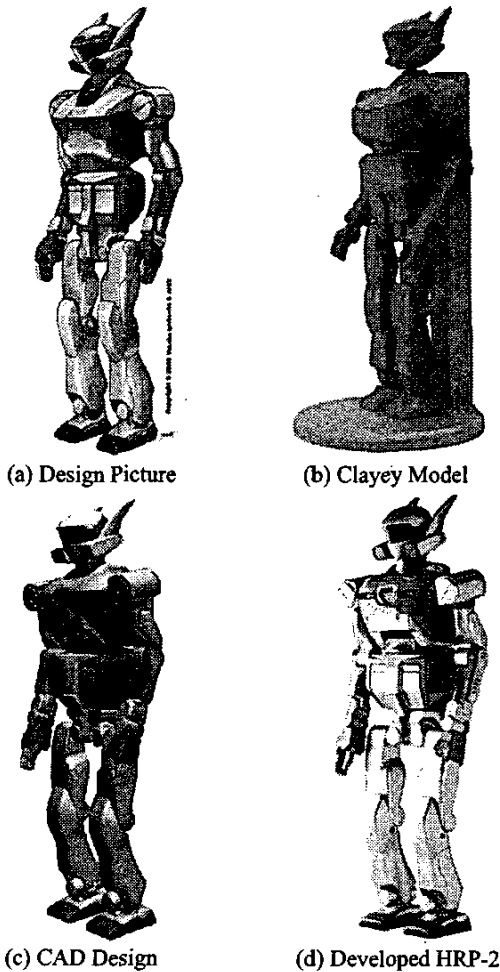

Figure 4. External Appearance of HRP-2

Figure 4 (a) shows an original sketch designed by him. Based on his original design, we had made several clayey models whose size is quarter of a final HRP-2 by way of trial. One of examples is shown in Figure 4 (b). When we made them, needless to say that we considered indispensable parts such as actuators, motor drivers, computers, batteries, and et al. His advices are very useful for appearance design of humanoid robot. One example of his advices is that the ratio of each body-parts is very important for personification and friendliness. Especially his particularity is a design of face for a well-proportioned figure. Although HRP-2 has three CCD cameras inside of a head module, its size is one eighth of height by mounting two of three on both cheeks as shown in Figure 5. This configuration makes distances between three cameras longer, while the face is smaller compared with HRP-2P [12]. The longer distance between cameras brings more precise recognition of visual system.

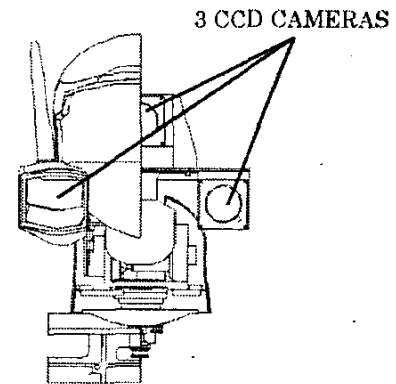

Figure 5. Configuration of Head Module

After several trials using clayey models and 3D CAD models, we decided a final CAD design. That is shown in Figure 4 (c), which is the almost same as its original design. HRP-2 as shown in Figure 4 (d) was finally developed.

4. Mechanical Design

As mentioned in former section, the design concepts of HRP-2 are light, compact, but performable for application tasks like cooperative works in the open air. To realize HRP-2, several distinctive mechanisms are employed. In this section, the principal mechanical designs are introduced with details.

4.1. Movable Range of Each Joint

The design policy for movable range of each joint is the same as that employed for HRP-2P.

First, we designed that to be about the same as that of standard human so that a humanoid robot performs human tasks as well as a human. Table 2 (a) shows the data on movable range of head, right arm, right hand, waist, and right leg of standard human [13].

Table 2. Movable Range of Each Joint

| Joint | | (a) Standard Human | (b) HRP-2 |
|------------|----------|---------------------|----------------------|
| Head | R | -50 deg. to 50 deg. | no existence. |
| | P | -50 deg. to 60 deg. | -30 deg. to 45 deg. |
| | Y | -70 deg. to 70 deg. | -45 deg. to 45 deg. |
| Right Arm | Shoulder | R | -90 deg. to 0 deg. |
| | | P | -180 deg. to 50 deg. |
| | | Y | -90 deg. to 90 deg. |
| | Elbow | P | -145 deg. to 0 deg. |
| | | Y | -90 deg. to 90 deg. |
| | Wrist | R | -55 deg. to 25 deg. |
| P | | -70 deg. to 90 deg. | |
| Right Hand | P | 0 deg. to 90 deg. | |
| Waist | R | -50 deg. to 50 deg. | |
| | P | -30 deg. to 45 deg. | |
| | Y | -40 deg. to 40 deg. | |
| Right Leg | Hip | R | -45 deg. to 20 deg. |
| | | P | -125 deg. to 15 deg. |
| | | Y | -45 deg. to 45 deg. |
| | Knee | P | -0 deg. to 130 deg. |
| | Ankle | R | -20 deg. to 30 deg. |
| | | P | -20 deg. to 45 deg. |

R: Roll axis, P: Pitch axis, Y: Yaw axis

However, as shown in Table 2 (b), which shows the designed movable range of HRP-2, some movable ranges of humanoid joint should be extended or reduced by the same reason for HRP-2P [10].

Compared HRP-2 and HRP-2P, some movable range, such as that of head pitch joint and that of shoulder roll joint, are slightly different. The reason is just simple and comes from the interference between exterior parts. We decided that we should rather design a friendly appearance than ensure their movable range. These designed movable range of each joint of HRP-2 are however enough for our purpose [12].

4.2. Cooling System incorporated in Leg Actuator

A cooling system incorporated in leg actuator is newly employed for HRP-2. The reason to employ that comes from the experience in using HRP-2P. This section explains why/how we designed the cooling system incorporated in leg actuator.

When we experimented on biped walks at using HRP-2P, HRP-2P could not keep up continuous walks for about 30 minutes or over. The main reason is caused by a rise in temperature of actuators. According to higher temperature of actuator, the output characteristic of generated torque is slightly changed and the stability of biped walks decreases. In the worst case, the winding of actuator is affected and HRP-2P falls over.

To overcome this problem, employing more powerful actuators can be considered as one of solutions. However, more

powerful actuators are selected, the heavier humanoid is constructed and furthermore the more powerful actuators are required. To solve above problem smartly, we examined several cooling systems incorporated in leg actuator and evaluated them.

Figure 6 shows one example explaining a temperature variation of actuator's housing during walks. Looking at Figure 6, it is apparent that the cooling systems have an effect on suppressing the rise in temperature of actuator. Since the cooling system, which ventilates the inside of link, is most effective for control temperature, ventilating fans are mounted on leg's links in HRP-2. As a result, this cooling system incorporated in the leg actuators allows enhanced continuous walking endurance.

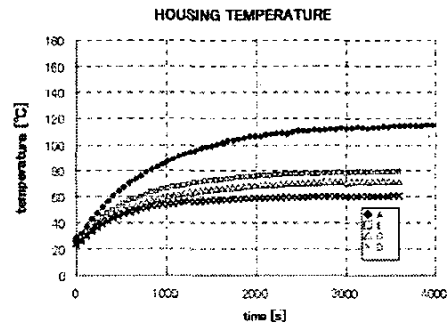

Figure 6. Comparison with Cooling Approaches

- A: Without cooling system
- B: With cooling fan mounted near knee joint for circulation
- C: With cooling fan mounted near hip joint for circulation
- D: With cooling fan for ventilating the inside of link

4.3. FEM Analysis

Another problem, which we had at using HRP-2P, was a mechanical resonance. Consequently, stiffen servos could not be realized and motion performances were restricted.

To overcome the mechanical resonance and to improve a high stiff structure, FEM analyses were minutely carried out with regard to main parts based on obtained data from using HRP-2P. Optimizing form is also considered. Figure 7 shows one example on a waist part. By the careful design with FEM analyses, links and axial stiffness are significantly upgraded to improve walking motion and operational performance.

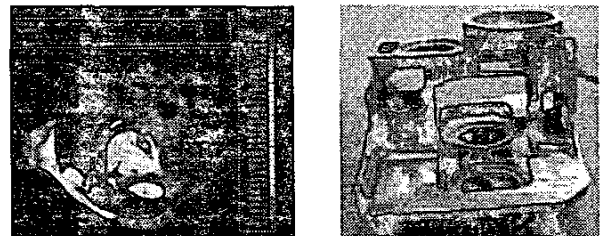

(a) FEM Analysis (b) Cast Part

Figure 7. Waist Part

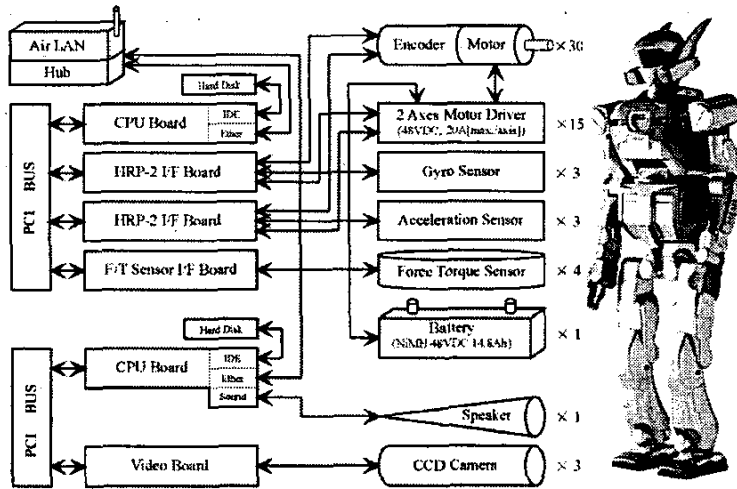

Figure 8. Electrical System of HRP-2

4.4. Cantilever Type Structure in Hip Joint

HRP-2 inherits the cantilever type structure from its leg module HRP-2L [14, 15] and its prototype HRP-2P. The reason is that the cantilever type structure, which enables to have less collision between both inside upper-limbs and enables to cross legs, brings to HRP-2 following advantages.

One advantage is that this structure is suitable for prevention of tipping over. By shaping the support polygon, which is made by supported legs (or single supported leg) [14], for the phase of double supported legs immediately and appropriately, the tipping over might be prevented, even if humanoid robot begins to tip over. The cantilever type structure enables to have a wide area of landing point for swinging leg and can appropriately shape the support polygon for the phase of double supported legs by selecting the landing point of swing leg. Especially, crossing legs further enables to make the support polygon be on the opposite side of supported leg.

The other advantage is that this structure enables to a cross-legged walk such as a walk on balance beam. HRP-2 would be able to pass, even if walking paths are narrow and limited.

4.5. Waist Joint

HRP-2 inherits the waist joint from HRP-2L and HRP-2P, since the waist joint also brings several advantages.

One is that HRP-2 can get up by a humanoid robot's own self by using a waist joint with 2 D.O.F. (pitch axis and yaw axis) [16]. Another is that HRP-2 can be lithe in build. The more lithe the upper body is, the smoother its gait is. Another is that the moment generated in the yaw axis of HRP-2 can be suppressed by using waist motion. This compensation is applied for high-speed walks. Furthermore, the waist joint makes working space of arm extended. Although HRP-2 has 6 D.O.F. in each arm and 1 D.O.F. in each hand, waist motion gives redundancy to the arm motion.

5. Electrical Design

In the electrical design for HRP-2, several efforts for light weight and realization of compact body were adopted as well as HRP-2P. In addition, the electrical system of HRP-2 was designed with great care to achieve reliability compared with that of HRP-2P. In this section, the principal electrical designs are introduced with details.

5.1. Computer System

Figure 8 shows the electrical system of HRP-2, while the left-hand side of Figure 8 shows the computer systems of HRP-2. Figure 8 tells us that HRP-2 has two CPU boards in the body. One of them is utilized for the real-time controller of whole body motion, while the other is utilized for non-real-time control system including the VVV software system [17] and the sound system. Although these computer systems seem to be the same as those of HRP-2P, almost all the boards were renewed for reliability in HRP-2.

For example, a back-plane board was renewed by the following reason. The back-plane board employed for HRP-2P was occasionally hung up on some noise such as PWM noise generated by servo motor drivers. To achieve reliability of computer system, a new back-plane board for HRP-2 use was developed. The type of bus is PCI bus that becomes the most popular bus in industrial field.

Another renewed board is a CPU board, though the exclusive CPU board was not developed for HRP-2. We selected the CPU board, which is based on Pentium III and has a sound function, on the market. Since the sound board used in the computer system of HRP-2P became useless, the more compact-size of computer system was achieved in HRP-2.

The HRP interface board is also renewed with minor changes for reliability.

By renewing several boards, the computer system reliability has great progress in HRP-2.

5.2. Noise Reduction

Several efforts for noise reductions were adopted for the electrical system reliability.

The first effort for noise reduction is that we developed several exclusive circuit boards for less spatial wiring. The reason is that spatial wiring has a possibility of making inductance and would generate unexpected noise. Figure 9 shows one example of developed circuit boards, which is the translator board for routing signal lines. Although we were troubled with noise problems at using HRP-2P that has a lot of spatial wiring, noise problems were markedly decreased and reliability was improved in HRP-2.

Uniting electrical devices and harnessing them are also efforts for noise reduction because of less spatial wiring. Concretely, servo driver modules, power units, battery units, gyro sensor unit, acceleration sensor unit, and et al. are united and/or harnessed. Figure 10 shows battery units developed for HRP-2.

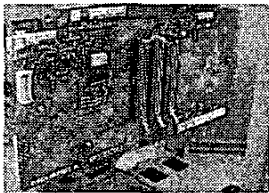

Figure 9. Translator Board

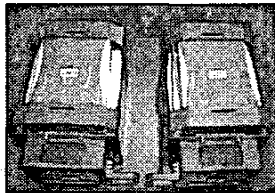

Figure 10. Battery Units

These efforts are also effective in making compact-size electrical system.

6. Experiments

The basic experiments were carried out to confirm whether HRP-2 could actually make several motions.

Figure 11 shows the experimental results on HRP-2's walk on a narrow path. Eight photographs were taken sequentially every 1.0 [sec]. Looking at Figure 11, it is observed that the cantilever type structure in hip joints enables to make HRP-2 cross legs. Although it is hard for humanoids to keep a balance on a balance beam as well as a human, we confirmed that HRP-2 was successfully able to walk on the narrow path.

Figure 12 shows the experimental results on HRP-2's coping with uneven surface. Eight photographs were taken sequentially every 2.5 [sec]. First seven photographs show closed up feet with wide view photographs. Here we defined the uneven surface to have a height difference of less than 4 [cm] with inclines up to 5 [%], which are about 2.86 [deg.]. From these experiments, we confirmed that HRP-2 was able to cope with uneven surface.

Figure 13 shows the experimental results on HRP-2's walk whose speed are 2.5 [km/h]. Eight photographs were taken sequentially every 1.0 [sec]. The moment generated in the yaw axis of HRP-2 was suppressed by using waist motion. As shown in Figure 13, it is apparent that HRP-2 was able to walk stably at 2.5 [km/h]. Presently stable walks up to 2.5 [km/h] have been realized, though its target was up to 2.0 [km/h] at this development. These experiments identified that links and axial stiffness were significantly upgraded.

Figure 14 shows the experimental results on cooperative works with a human and HRP-2. These photographs were taken at the meeting announcing the results of HRP on February 26 2003. As shown in these photographs, we were able to achieve the development of humanoid robot that can carry objects such as panels and tables with a human.

Figure 15 shows the experimental results on HRP-2 that lies down and gets up from floor. These photographs were also taken at the meeting announcing the results of HRP. We believe that HRP-2 and its prototype HRP-2P are the first humanoid robots that have the human-size, can lie down, and can get up.

From Figures 11 to 15, we are convinced of successful development of HRP-2.

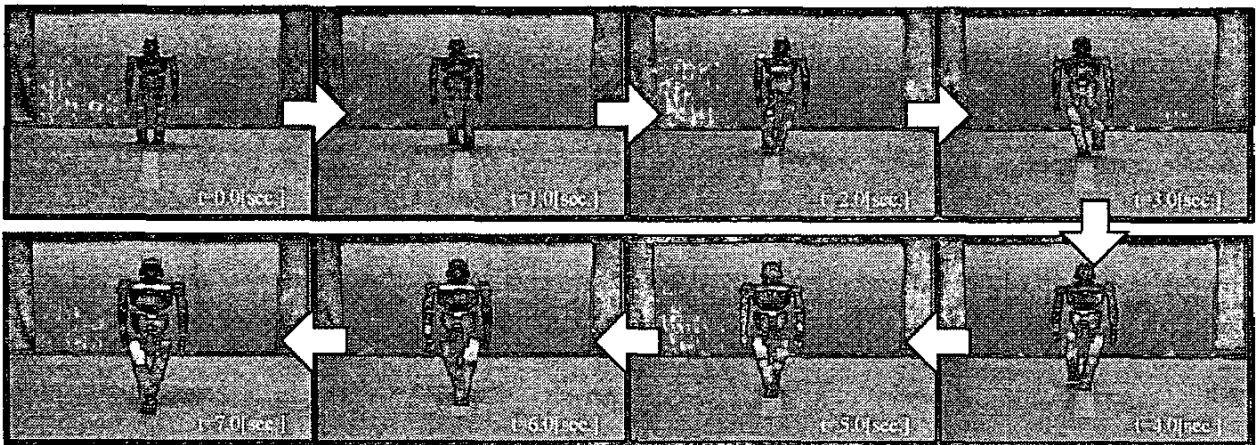

Figure 11. Walk on Narrow Path [Japanese "OIRAN" Walk] (Sequence photographs: 1.0 [sec/frame])

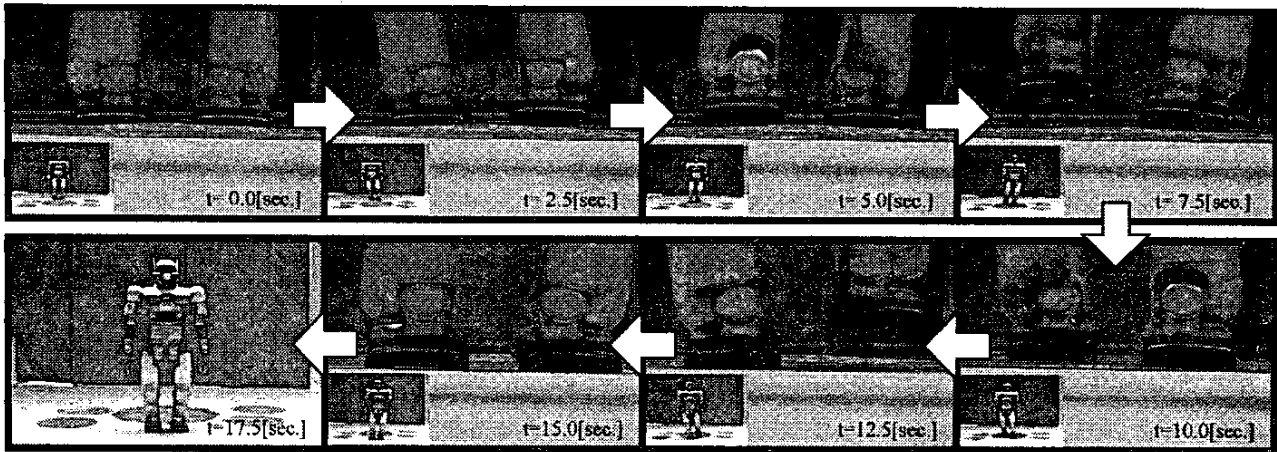

Figure 12. Walk on Uneven Surface with 5 [%] Slopes (Sequence photographs: 2.5 [sec/frame])

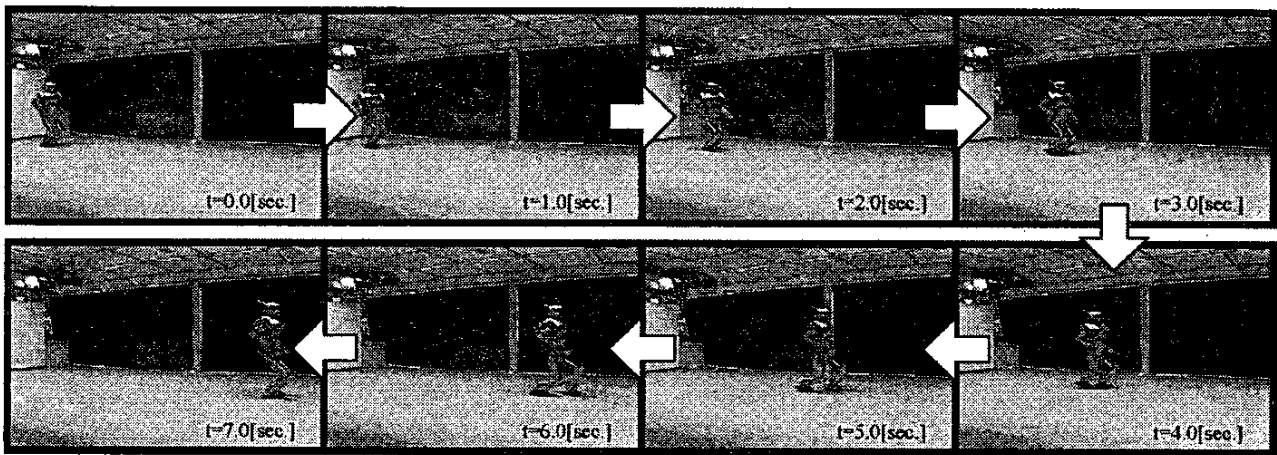

Figure 13. 2.5 [km/h] Walk (Sequence photographs: 1.0 [sec/frame])

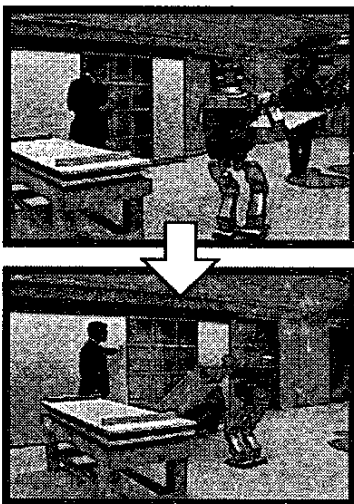

Figure 14. Cooperative Works with a Human

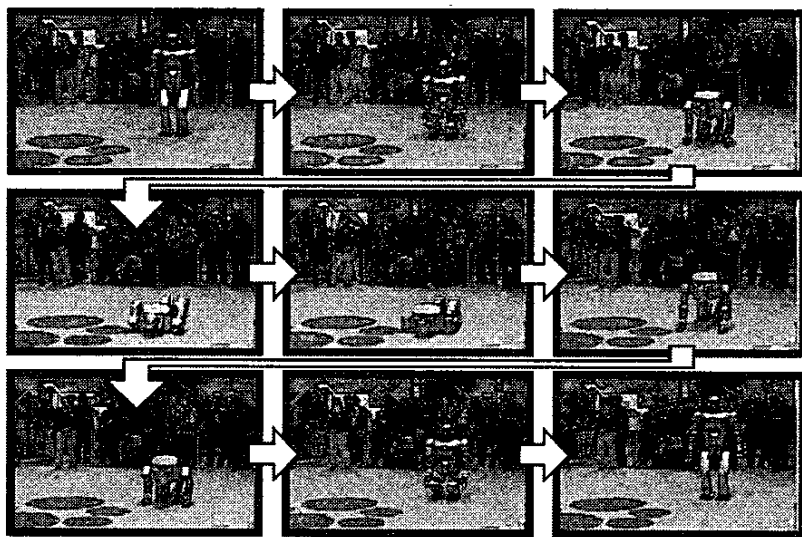

Figure 15. Lying down and Getting up of HRP-2

7. Conclusions

This paper presented how we developed the humanoid robot: HRP-2, which has a ability to walk on narrow paths, to cope with uneven surface, to walk at two third level of human speed (2.5 [km/h]), to lie down, and to get up by a humanoid robot's own self. Several distinctive mechanisms such as a cantilever type structure in hip joint and a waist joint mechanism are employed for HRP-2. This paper also presented the detail of appearance design, mechanism design, electrical design, its specifications, and features upgraded from its prototype.

Future works include more walking experiments in the open air. The developments of controller for walk with more stable balance, controller for application tasks, integration of vision system, and integration of intelligence will also be investigated in the future. A development of next humanoid HRP-3, which reflects experiences obtained from using HRP-2, is also our future work.

Acknowledgments

This research was supported by the Humanoid Robotics Project (HRP) of the Ministry of Economy, Trade and Industry (METI), through the New Energy and Industrial Technology Development Organization (NEDO) and the Manufacturing Science and Technology Center (MSTC). The authors would like to express sincere thanks to them for their financial supports.

This successful development of humanoid robot HRP-2 would not be achieved without helpful discussions from our cooperative members. The authors would like to thank sincerely the members of the Humanoid Research Group (HRG) of the National Institute of Advanced Industrial Science and Technology (AIST), Dr. K. Yokoi, Dr. K. Harada, and Mr. K. Fujiwara. We would also like to acknowledge Mr. T. Kawada, Mr. K. Chiba, Mr. A. Hayashi, Mr. M. Ishizaki, Mr. N. Kanehira, Mr. M. Kawaguchi, Mr. G. Miyamori, Mr. T. Ohsawa, Mr. S. Ohta, and Mr. T. Okano, who are members of the Aircraft and Mechanical Systems Division of KAWADA Industries, Inc. It is not too much to say that their hard work and passion completed HRP-2 for so short developing period. And further, we would like to acknowledge Mr. Y. Izubuchi for the cool design and Prof. H. Inoue who was a project leader of HRP for his valuable comments that led into this successful development of HRP-2.

References

- [1] K. Nishiwaki, T. Sugihara, S. Kagami, F. Kanehiro, M. Inaba, and H. Inoue, "Design and Development of Research Platform for Perception-Action Integration in Humanoid Robot: H6," Proc. IEEE/RSJ Int. Conference on Intelligent Robots and Systems, pp. 1559-1564, 2000.
- [2] M. Gienger, K. Löffler, and F. Pfeiffer, "Towards the Design of Biped Jogging Robot," Proc. IEEE Int. Conference on Robotics and Automation, pp. 4140-4145, 2001.
- [3] K. Löffler, M. Gienger, and F. Pfeiffer, "Sensor and Control Design of a Dynamically Stable Biped Robot," Proc. IEEE Int. Conference on Robotics and Automation, pp. 484-490, 2003.
- [4] Y. Kuroki, T. Ishida, J. Yamaguchi, M. Fujita, and T. Doi, "A Small Biped Entertainment Robot," Proc. IEEE-RAS Int. Conference on Humanoid Robots, pp. 181-186, 2001.
- [5] Y. Kuroki, M. Fujita, T. Ishida, K. Nagasaka, and J. Yamaguchi, "A Small Biped Entertainment Robot Exploring Attractive Applications," Proc. IEEE Int. Conference on Robotics and Automation, pp. 471-476, 2003.
- [6] K. Hirai, "Current and Future Perspective of Honda Humanoid Robot," Proc. IEEE/RSJ Int. Conference on Intelligent Robots and Systems, pp. 500-508, 1997.
- [7] K. Hirai, M. Hirose, Y. Haikawa, and T. Takenaka, "The Development of Honda Humanoid Robot," Proc. IEEE Int. Conference on Robotics and Automation, pp. 1321-1326, 1998.
- [8] M. Hirose, Y. Haikawa, T. Takenaka, and K. Hirai, "Development of Humanoid Robot ASIMO," Proc. IEEE/RSJ Int. Conference on Intelligent Robots and Systems, Workshop2 (Oct. 29, 2001), 2001.
- [9] H. Inoue, S. Tachi, Y. Nakamura, K. Hirai, N. Ohya, S. Hirai, K. Tanie, K. Yokoi, and H. Hirukawa, "Overview of Humanoid Robotics Project of METI," Proc. the 32nd Int. Symposium on Robotics, pp. 1478-1482, 2001.
- [10] K. Kaneko, F. Kanehiro, S. Kajita, K. Yokoyama, K. Akachi, T. Kawasaki, S. Ota, and T. Isozumi, "Design of Prototype Humanoid Robotics Platform for HRP," Proc. IEEE/RSJ Int. Conference on Intelligent Robots and Systems, pp. 2431-2436, 2002.
- [11] K. Yokoyama, J. Maeda, T. Isozumi, and K. Kaneko, "Application of Humanoid Robots for Cooperative Tasks in the Outdoors," Proc. IEEE/RSJ Int. Conference on Intelligent Robots and Systems, Workshop2 (Oct. 29, 2001), 2001.
- [12] K. Yokoyama, H. Handa, T. Isozumi, Y. Fukase, K. Kaneko, F. Kanehiro, Y. Kawai, F. Tomita, and H. Hirukawa, "Cooperative Works by a Human and a Humanoid Robot," Proc. IEEE Int. Conference on Robotics and Automation, pp. 2985-2991, 2003.
- [13] Y. Kagawa, "Bio-Engineering Technical Terms Dictionary," Japanese Standards Association, ISBN 4-542-20125-2, (in Japanese).
- [14] K. Kaneko, S. Kajita, F. Kanehiro, K. Yokoi, K. Fujiwara, H. Hirukawa, T. Kawasaki, M. Hirata, and T. Isozumi, "Design of Advanced Leg Module for Humanoid Robotics Project of METI," Proc. IEEE Int. Conference on Robotics and Automation, pp. 38-45, 2002.
- [15] N. Kanehira, T. Kawasaki, S. Ota, K. Akachi, T. Isozumi, F. Kanehiro, and K. Kaneko, and S. Kajita, "Design and Experiment of Advanced Leg Module (HRP-2L) for Humanoid Robot (HRP-2) Development," Proc. IEEE/RSJ Int. Conference on Intelligent Robots and Systems, pp. 2455-2460, 2002.
- [16] F. Kanehiro, K. Kaneko, K. Fujiwara, K. Harada, S. Kajita, K. Yokoi, H. Hirukawa, K. Akachi, and T. Isozumi, "The first Humanoid Robot that has the Same Size as a Human and that can Lie down and Get up," Proc. IEEE Int. Conference on Robotics and Automation, pp. 1633-1639, 2003.
- [17] Y. Sumi, Y. Kawai, T. Yoshimi, and F. Tomita, "3D Object Recognition in Cluttered Environments by Segment-Based Stereo Vision," International Journal of Computer Vision, 46, 1, pp.5-23, 2002.