

Development of a Hybrid Humanoid Platform and Incorporation of the Passive Actuators

V. Santos, *Member, IEEE*, R.A.S. Moreira
M. Ribeiro, F. Silva

Abstract—This paper describes the design and development of a new hybrid humanoid platform conceived to use both active and passive actuators. Power efficiency and mechanical response capability of the robot were the main concerns driving this development. Maintaining the use of off-the-shelf RC servomotors, due to their limited cost and commercial availability, the platform was nonetheless custom-designed for lightness, mechanical stiffness and prone to vast sensorial enrichment for future advanced control. Low-cost actuators may degrade and perform poorly and erroneously in demanding conditions; therefore, one major inspiration for this work relies on the potential energy storage mechanism, using elastic elements to overcome the motors limitation, avoiding their operation near the limits, while saving energy and wearing, and also obtain faster responses of the overall platform in various motion schemes and gaits. A standard simulation environment allows the initial design and future tuning of the passive actuators for several joints in motion tasks. The early simulation results show that the elastic elements approach indeed eases the actuators tasks and is a must in the future development of the new platform now presented.

I. INTRODUCTION

HUMANOID robots are complex machines with complex requirements. Most of these are concerned with autonomy: either of decisions (control) or computational and processing power, but also in energy storage and efficiency. Artificial legged locomotion is well-known to be much less efficient than wheeled locomotion, and the Lagrangean alternations between potential and kinetic energy are usually all dealt with active power in the non-conservative actuators such as electric motors. This has two issues to bear in mind: power saving and operation limits of the actuators to cope with more extreme demands of motion.

The usage of elastic passive actuators is not new and several works have taken place. What seems to be underexploited, though, is an appropriate combination of simple actuators (motors) with appropriate and adjustable passive elements such as springs, elastic rubber bands and other similar mechanical energy storage devices. Hybrid actuation is a powerful practice in machine design and control in order to achieve more dynamics and less control,

greater energy efficiency and, expectantly, better reactivity during transients or fast responses.

To deal with this concern, practical design issues must be taken into account and although a huge variety of formats exists for rubber bands and springs (spiral, helical, leaf, etc.) the simplicity of fixation, accommodation, replacement and tuning demand some attention in designing a humanoid platform to comply with those requirements and that can cope with a large variety of passive elements, even with their absence or possibly variable properties.

This paper proposes, therefore, a new humanoid structure, designed from scratch in light and stiff materials, suited for the installation of linear elastic elements in a similar way as ligaments and muscles in the human body. Special attention is given to the lower limbs assembly since this is the central element for locomotion tasks. The paper continues in section 2 that describes the new design of the two legs from the foot up to the hip, where specific concerns and cares were addressed. Section 3 presents a brief description on actuation challenges and it describes details on the passive actuator of the knee. Section 4 describes some steps towards hybrid control and the first preliminary experiments. Section 5 draws the main conclusions about the success of the approach and entails the next steps to complete the development of a platform keen to fast response, when the appropriate control will be installed.

II. MECHANICAL DESIGN OF A NEW PLATFORM

The new humanoid skeleton structure has been conceived according to a set of design requirements, such as kinematically simple structure, light weight and compact size, backlash-free actuation and energy efficiency. From the initial sketches, the concern on simple but effective structural solutions has been driving the conceptual process, allowing though the inclusion of adjusting mechanisms able to tune the mechanical components behaviour.

These simple solutions include axles' intersection on universal joints (for easy future modelling and control), multiple and adjustable anchoring points for elastic elements, the implementation of antagonist passive actuators in joints operating around a central point, and also simple mechanisms to adjust pulleys and belts tensions to account for natural wearing of these kinematic components. For manufacturing purposes, some levels of symmetry and ankle-hip duality have been devised. Installation of force sensors

Manuscript received July 23, 2010.

V. Santos and R. Moreira are with the Department of Mechanical Engineering, Center for Mechanical Technology and Automation, TEMA, University of Aveiro, Portugal. E-mails: vitor@ua.pt, rmoreira@ua.pt

M. Ribeiro and F. Silva are with the Department of Electronics, Telecommunications and Informatics/IEETA of the University of Aveiro. E-mail: miguelribeiro@ua.pt, fmsilva@ua.pt (corresponding author).

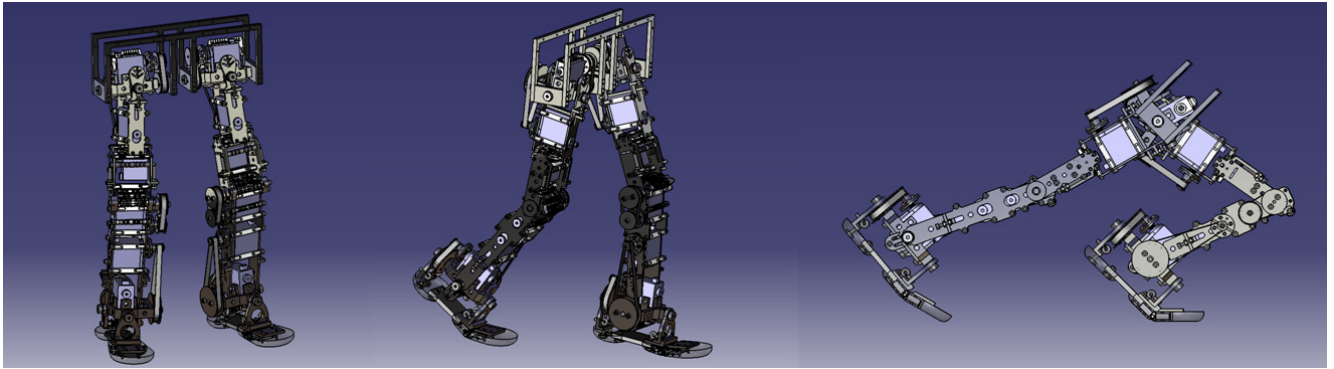

Fig. 1 - Model of the lower limbs of the new platform illustrating some postures.

and other perception components was also kept in mind, allowing the easy integration of such dynamic behaviour transducers. The kinematic degrees of freedom are similar to those described by the human skeleton and the structure dimensions are related to a 6 month child.

The new structure has already started in manufacturing and the lower limbs are ready for the first experiments. Fig. 1 illustrates the CAD model of the lower extremities and some of the possible postures.

A. Articulated foot

Contrary to the conventional rigid foot assembly, the proposed design intentionally mimics the real passive behaviour of human foot by considering a hinged and partitioned foot (Fig. 2). This approach increases the period of humanoid equilibrium during a normal walk task since the folded foot ensures a real support up to the last ground contact stage. In the present form, the front section of the foot is connected to the main base foot section through a set of controlled stiffness spring bending laminas, providing an impulsive mechanism during the foot rising movement, similar to the real musculoskeletal kinematics behaviour.

This construction enables future upgrade improvement by adopting passive or active control of the link stiffness or by incorporating an active mechanism simulating the front foot section tendons effect. Additionally, the principal foot section, which provides the main vertical support for the humanoid, is also partitioned into two sections enabling the torsion of the foot to maximize the foot-surface contact.

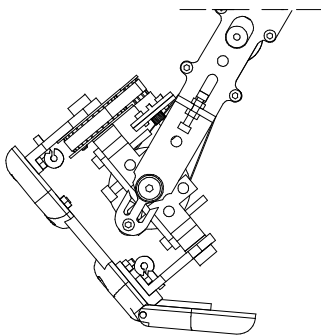

Fig. 2 - Articulated foot construction detail

B. The Ankle joints

The ankle joint is formed by a cross axe assembly enabling the usual Flexion/Extension and the Dorsiflexion-Plantarflexion degrees of freedom (Fig. 3). The cross axe assembly provides a kinematic joint mimicking the ball joint existing in the human skeleton. Furthermore, this special joint construction reduces significantly the motion inertia since most of it is related to the axes, bearing and associated gears or transmission pulleys, which, in this case, are located near the rotation point.

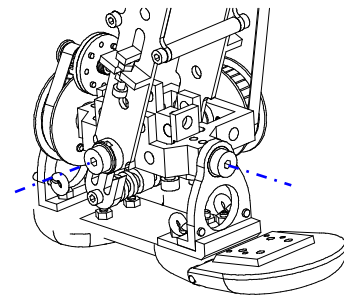

Fig. 3 - Ankle joint

C. The knee

The knee joint (Fig. 4), mimicking the degree of freedom related to the Flexion/Extension movement, is one of the most important joints for the legs kinematic assembly of the proposed humanoid. In conjunction with the hip joint, the knee joint is responsible for most of the weight displacement. For this reason, a passive system using extensible counteracting springs is designed, acting as a potential energy storage system.

By adopting this elastic subsystem, the skeleton is intended to attain a null-momentum equilibrium condition for the vertical position, ensuring the upright position of the skeleton at a rest state (motors turned off) and minimizing the required peak motor torque value. As for the remaining kinematic joints, the knee assembly ensures a rotation range similar or even exceeding the human kinematics.

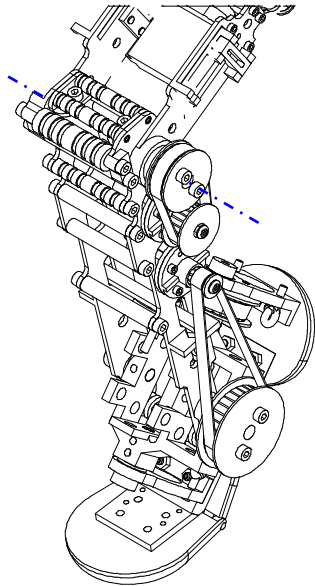

Fig. 4 - Knee joint.

D. The hip joint and connection of the legs

The hip joint enables the three degrees of freedom for this kinematic joint: Flexion/Extension, Adduction/Abduction and Lateral/Medial rotation. The Flexion/Extension and Adduction/Abduction movements are combined into a single joint, using a cross axle assembly similar to the one designed for the ankle joint (Fig. 5). This assembly mimics the ball joint provided by the acetabular cup/femoral head joint. The Lateral/Medial rotation degree of freedom is provided by a rotation joint located in the upper section of each leg (Fig. 5). Despite the kinematics simplicity for this rotation joint, its longitudinal force transmission capability is an important issue during the joint design process. To reduce the rotation inertia and considering the low weight of the head/torso/upper limbs sections of the humanoid, an axial/rotation low friction PTFE-coated bushing was considered instead of the conventional axial ball bearing.

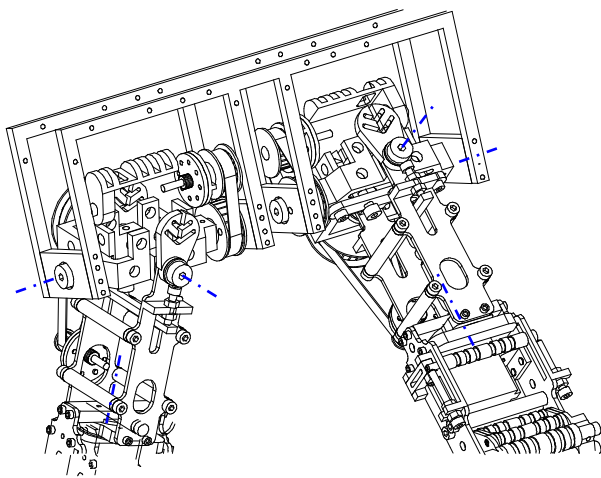

Fig. 5 - Hip joints.

Similarly to the knee joint, specially designed extensible springs were considered to ensure the upright condition for minimum motor load and minimize the peak torque value for the Flexion/Extension movement.

III. HYBRID ACTUATION SYSTEM

A. Actuation Challenges

An increasing number of studies support the idea that the structure and mechanical characteristics of the robot body (*i.e.*, morphology) play a crucial role in behavior generation and control. The morphology determines the kinematics and dynamics of the robot, and thereby the possible repertoire of behaviors, as well as affects the control required for these behaviors. The relevance of this idea have become apparent with the seminar work of Tad McGeer [1] who built self-stabilizing passive mechanisms which could walk down a slope in the absence of control. Since then, many other robots have been developed demonstrating how well-designed morphologies can lead to reduction in control requirements and improved efficiency [2][3][4].

The current research challenge is to design innovative robotic systems that combine energetic efficiency with the ability to execute a variety of complex maneuvers without complex computation. Central to the study is the need to work out principles of biological systems and transfer desirable properties to the robot design, both existing and novel solutions [5].

From a mechanical design standpoint, several new technologies can contribute to an economical and versatile robot. The most obvious, yet most challenging, approach is to develop muscle-like actuators (*e.g.*, McKibben muscles or emerging technologies based on electro-active polymers). At present time, these kinds of actuators are becoming commercially available and robotic applications will soon test their suitability for walking [6].

Another promising actuation concept for walking robots is series-elastic actuators, a combination of a spring and a motor [7]. The series elasticity allows to store and release energy during one gait cycle. During energy release, the power output can exceed the peak power limit of the motor. Hybrid actuation is another powerful practice in machine design and control in order to achieve “more dynamics” and “less control”, greater energy efficiency and, expectantly, better reactivity during transients or fast responses [8][9].

In line with this, the strategy proposed in this paper is to exploit the strengths of active actuation (Hitec digital servo motors) in terms of versatility and the advantages of passive mechanisms. For this purpose, the legs accounts for a set of insertion points that allow the inclusion of different mechanisms like springs, elastic fibers and other basic mechanisms of energy conservation. Although these design features can improve energy efficiency, they tend to be ill-suited for theoretical control design. Further, there are few

theoretical methods which serve to analyze the role of passive elements combined with active actuation for reduce power requirements. This fundamental gap justifies our intention to perform a research effort, from various perspectives, in order to better understand the relationship among the mechanical structure, its dynamics and control.

B. The knee passive actuator

Although elastic components are being incorporated in most of the platform joints, the knee presents a particular interest since it is deeply involved in more demanding gaits or locomotion tasks. Indeed, the knee may be subjected to high torques when bending to large angles (Fig. 6) and also when high responses are needed.

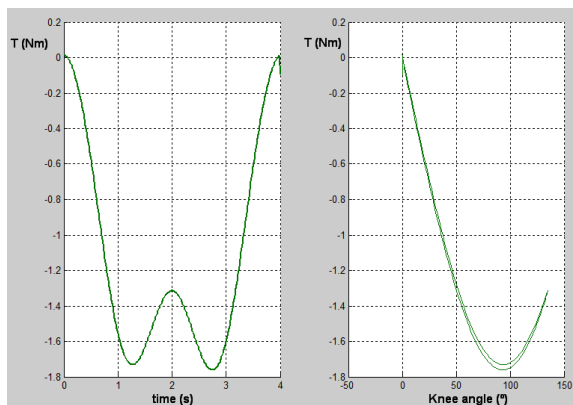

Fig. 6 - Torque developed by the knee motor to bend from upright position (0°) down to 135° and go back in a full cycle of 4 seconds. The right chart shows the closed cycle of the required torque.

Supporting gravity is usually an apparent drawback in many humanoid robots, but that can be turned into an advantage if storing potential energy is possible. This can be done by the use of elastic energy storage elements. Helix springs may appear as a suited solution, namely for their linear behaviour with the torsion angle, which is interesting for control and modelling purposes. However, helix springs may turn out to be mechanically hard to tune and even troublesome to attach to the links they are expected to bind.

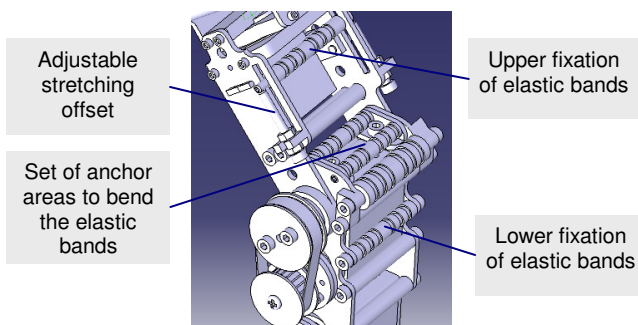

Fig. 7 - Detail of fixation and anchor points for the elastic bands.

The alternative in this project has been to use linear elastic rubber bands duly guided through the structure around the knee. Moreover, the system was conceived in a way that these elastic bands remain confined in a path and may be

manually tuned by stretching them and imposing an adjustable initial force offset (Fig. 7).

Although the force may be considered proportional to the elongation of the elastic band, that elongation may not be linear with the knee angle, nor will be the resistant torque that develops against that bending.

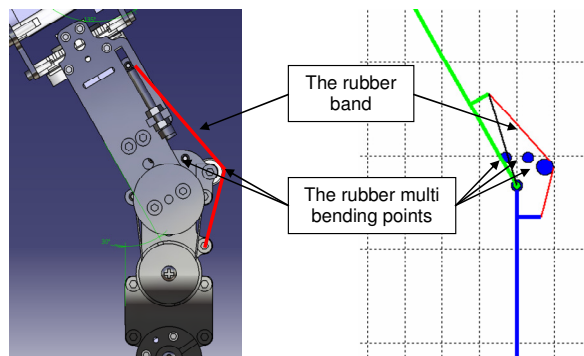

Fig. 8 - Model of the deformation of the knee elastic band.

Fig. 8 illustrates a concept that allows keeping the torque generated by the passive actuator in raised levels throughout the full span of the knee joint. The multi bending points provide a stepwise adjustment of force direction to yield a more sustainable torque.

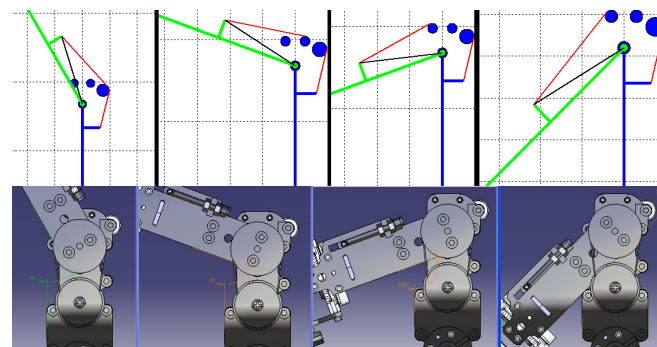

Fig. 9 - Sequence of knee angles (30°, 70°, 110°, 135°) to illustrate the changing direction of the force exerted by the elastic band to keep resulting torque at high levels across the full knee span.

The resulting torque is therefore monotonic with the angle (Fig. 10) and therefore usable as an additive torque component that will ease the task of the motor that drives the knee.

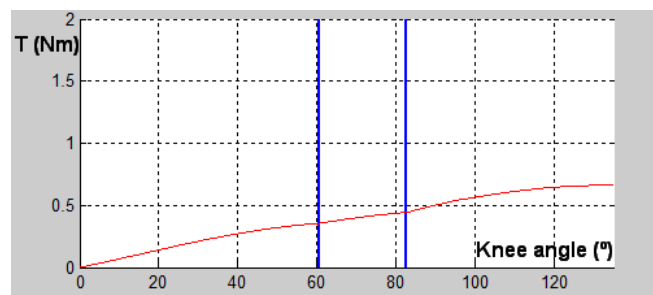

Fig. 10 - Plot of torque developed by the passive actuator on the knee. The vertical lines indicate where new bending points start operating.

IV. COMPUTING SYSTEM

The main long term idea behind this project is the design of a humanoid robotic platform that combines energetic efficiency with flexible and robust motion without complex computation. The work currently being performed focus on the construction of the lower extremities of the new robot to explore the hypothesis that human-like walking requires hybrid actuation and hybrid control systems. The primary challenge is to balance the need for human-like walking capabilities with the reality of relying on current technology in actuators, motor control, sensors, as well as with factors such as reliability, cost, and availability. A faster development phase is expected once the new platform will be able to reuse several components, structures and modules developed in the previous phase of the project [10]-[12], while optimizing others aspects that may require adjustments.

Current activities are concentrated on design concepts, technological solutions and the development and integration of hardware and software components to build a full-actuated small-size 20 degrees of freedom (DOFs) humanoid robot at reduced costs, but still aiming at a fully autonomous platform for research. Most of the final platform hardware was built and the first experimental results are promising (see Fig. 11).

The most relevant achievements of this implementation include the distributed computational system and the modularity at the system's level. A modular design was conceived to ensure easy maintenance and faster reproducibility, given the possibility of reusing specific modules, in terms of both hardware and software, with no major efforts.

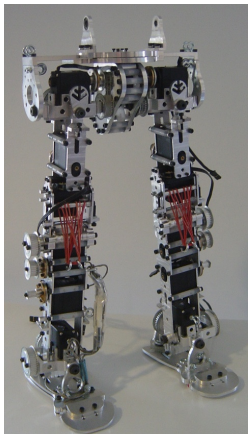

Fig. 11 - New humanoid platform based on active and passive actuators

A. Distributed control architecture

A distributed control architecture has been conceived having in mind the system's scalability, robustness, increased computational power and true effective parallelization of machine functions [10][11]. The proposed solution is based on a three level hierarchy of controllers: (1) the main control unit consists of an embedded PC104-based controller (Intel

Atom processor at 1.6 GHz) running Linux. This processing unit have the following major roles: capture images and process them, interfaces to remote monitoring and possibly control, and communicates by RS232 serial line with the master unit; (2) the master unit whose role is to gather and maintain the status of the system as well as establish the communication protocols between levels; and (3) the slave units, based on dsPIC microcontrollers seeded all over the robot's structure, are responsible for actuator direct control, sensor reading and immediate processing. The slave units are connected by a ECAN bus which also includes the master unit.

B. Low-level control

On-board full processing and autonomy is now possible in what concerns control and perception based on the distributed architecture in which independent and self-contained tasks may allow a standalone operation. This feature allows for a control system where centralized and local controls co-exist and compete to cope with the requirements of dynamic walking. Some motion joints have been grouped (*e.g.*, entire foot and knee in Fig. 12) by vicinity criteria and they are controlled locally by a dedicated board based on a dsPIC microcontroller. The selected servos have themselves a built-in motor, gearbox, position feedback and controlling electronics, making them practical and robust devices.

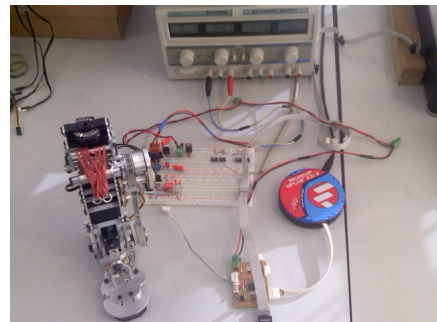

Fig. 12 - Experimental setup for the control of one leg

C. Force sensors

From the very beginning of the project, it was clear that the feet of the robot should be equipped with force sensors and force feedback should be introduced into the control system. The first decision was to develop a custom system based on strain gauges and to amplify the deformation of some stiff material [11]. Afterwards, a force-driven controller was successfully applied to demonstrate the possibility of keeping the humanoid robot in upright balance on an uneven surface or one whose slope changes [12]. For this purpose, it was considered feedback control from four sensors inserted into the foot corners. After calibration, the unbalanced force distribution was used as input to joint actuation and allowed some kind of local control laws to rule the robot behavior.

The custom-made strain-gauge based force sensors suffer from several limitations in what concerns material fatigue and reliability with the progressive and localized (asymmetric) structural damage that occurs when the stiff materials are subjected to continuous deformations. Nowadays, the feet of the robot are equipped with reliable force sensors: four miniature load cells are distributed by the principal foot's corners able to measure loads up to 5 lbs and with the most demanding requirements in terms of sensitivity, stiffness, linearity and hysteresis. Fig. 13 depicts the temporal evolution of the force sensing during manual pressure applied on the foot extremities.

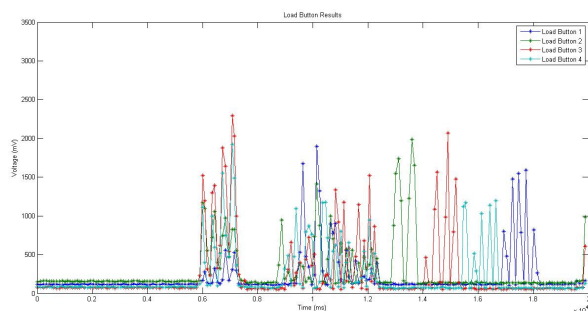

Fig. 13 – Temporal evolution of the force sensors when acting manually on the foot extremities

V. CONCLUSIONS AND FUTURE WORK

This paper describes the initial development stages of a new humanoid platform with the purpose of taking advantage of the hybrid approach of active and passive actuation combined. Special care is being taken in the mechanical conception of the system and some novelties were introduced, although only few of them are physically developed as this moment. The study is still evolving but it has already proven that the passive actuator on the knee definitely eases the task of the joint motor. An articulated foot has also been introduced and designed, and preliminary results are expected soon when the manufacturing completes. The team has previous know-how on platform design and construction and that will be of great value when installing the sensorial and control units.

The near future is very exciting, since force and other sensorial data will be used in a fully hybrid device, where hybrid covers not only the actuation and mechanical

component, but also in terms of control where the low-level coexists with others levels including learning. The efficiency of the machine due to the passive actuators is a must that will ensure better performance of motors that will operate far from their limits. Last, but not least, the expected energy savings will turn this platform on a competitive platform both for education and advanced research in many fronts.

REFERENCES

- [1] T. McGeer, "Passive Dynamic Walking" in *The International Journal of Robotics Research*, vol. 9, no. 2, 1990, pp. 62-82.
- [2] S. Anderson, M. Wisse, C.G. Atkeson, J. Hodgins, G. Zeglin and B. Moyer, "Powered Biped Based on Passive Dynamic Principles", in *Proceedings of the IEEE International Conference on Humanoid Robots*, 2005.
- [3] S.H. Collins and A. Ruina, "A Bipedal Walking Robot with Efficient and Human-like Gait", in *Proceedings of the International Conference on Robotics and Automation*, 2005.
- [4] D. Hobbelen and M. Wisse, "Limit Cycle Walking", in *Humanoid Robots: Human-like Machines*, edited by Matthias Hanckel, Vienna, AT: I-Tech Education and Publishing, ISBN: 978-3-902613-07-3, Chapter 14, 2007, pp. 277-294.
- [5] S.O. Anderson, M. Wisse, C.G. Atkeson, J.K. Hodgins, G.J. Zeglin and B. Moyer, "Powered Biped Based on Passive Dynamic Principles", in *Proceedings of the IEEE-RAS International Conference on Humanoid Robotics*, 2005, pp. 110-116.
- [6] K. Hosoda, T. Takuma, A. Nakamoto and S. Hayashi, "Biped Robot Design Powered by Antagonistic Pneumatic Actuators for Multimodal Locomotion", *Robotics and Autonomous Systems*, vol. 56, 2008, pp. 46-53.
- [7] G. Pratt, "Legged Robots at MIT: What's New Since Raibert", *IEEE Robotics and Automation Magazine*, Sept. 2000, pp. 15-19.
- [8] M. Wisse, G. Feliksdaal, J.v. Frankenhuyzen and B. Moyer, "Passive-Based Walking Robot", *IEEE Robotics and Automation Magazine*, June 2007, pp. 52-62.
- [9] D. Owaki and A. Ishiguro, "Enhancing stability of a passive dynamic running biped by exploiting a non linear spring", in *Proceedings of the IEEE/RSJ International Conference on Intelligent Robots and Systems*, 2006, pp. 4923-4928.
- [10] F. Silva and V. Santos, "Multipurpose Small-Cost Humanoid Platform and Modular Control Software Development", in *Humanoid Robots: Human-like Machines*, [ISBN: 978-3-902613-07-3], edited by Matthias Hanckel, 2007.
- [11] V. Santos and F. Silva, "Design and Low-Level Control of a Humanoid Robot Using a Distributed Architecture Approach", *Journal of Vibration and Control*, Special Issue on Modeling and Control of Artificial Locomotion Systems, vol. 12, n° 12, 2006, pp. 1431-1456.
- [12] M. Ruas, P. Ferreira, F. Silva and V. Santos, "Local-level Control of a Humanoid Robot Prototype with Force-Driven Balance", in *Proceedings of the IEEE/RSJ International Conference on Humanoid Robots*, Nov. 29 – Dec. 1, Pittsburgh, Pennsylvania, USA, 2007.