

D

C

B

A

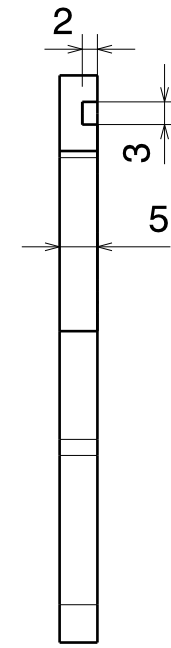
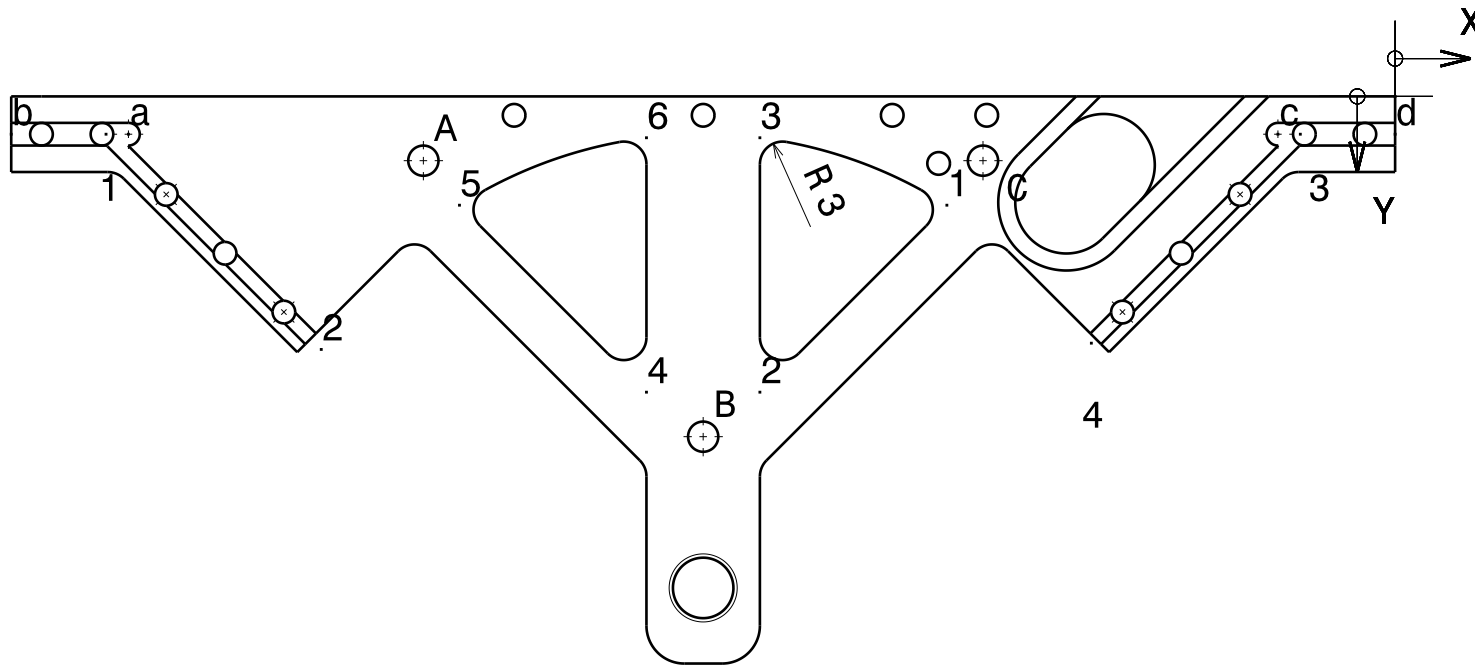

REF.	X	Y	Diameter
A	-128,5	8,5	4
B	-91,5	45	4
C	-54,5	8,5	4

REF.	X	Y
1	-59,27	14,39
2	-84	39,12
3	-84	5,47
4	-99	39,12
5	-123,73	14,39
6	-99	5,47

rasgo D3mm		
REF.	X	Y
a	-167,5	5
b	-183	5
c	-15,5	5
d	0	5

rasgo D2mm		
REF.	X	Y
1	-170,46	5
2	-142	33,46
3	-12,54	5
4	-40,17	32,63

D

A

4

3

2

1

4

3

2

1