

# FX<sub>2N</sub>

## FX<sub>2N</sub>-232-BD COMMUNICATION BOARD

### USER'S GUIDE

JY992D66001A

This manual contains text, diagrams and explanations which will guide the reader in the correct installation and operation of the FX<sub>2N</sub>-232-BD and should be read and understood before attempting to install or use the unit. Further information can be found in the FX SERIES PROGRAMMING MANUAL, FX<sub>2N</sub> SERIES HARDWARE MANUAL and FX-485PC-IF USER'S MANUAL.

## 1 INTRODUCTION

The communication board FX<sub>2N</sub>-232-BD for RS232C (hereinafter referred to as "232BD") can be connected to the main unit of the FX<sub>2N</sub> Series programmable controller, and used as the port for the following applications.

- (1) To perform data transfer between RS232C devices such as personal computers, bar code readers and printers.
- (2) To perform data transfer using the dedicated protocol between RS232C devices. For details of the dedicated protocol, refer to the users manual of the FX-485PC-IF.
- (3) To connect a programming tool.

And when the 232BD is used for the application (1) or (2) above, the communication format including the baud rate, the parity and the data length is specified by the parameters or the contents of the special data register D8120 of the FX<sub>2N</sub> programmable controller.

Only one 232BD can be connected to one base unit. Accordingly, the 232BD cannot be used together with the FX<sub>2N</sub>-485-BD or the FX<sub>2N</sub>-422-BD. When two or more RS232C units are required to be connected for the application, use the special block for RS232C communication.

### 1.1 EXTERNAL DIMENSIONS

Dimensions : mm (inches) Accessory : M3 self-tapping screws × 2, mounting bracket × 2

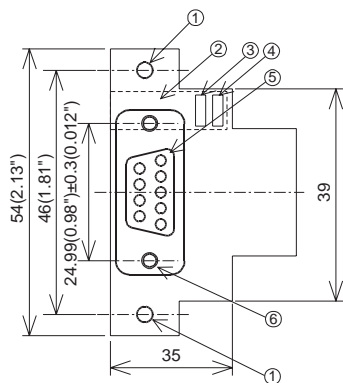

- ① Mounting holes <math>2-\phi 4.0 (0.16'')>
- ② Connector for programmable controller
- ③ RXD LED : Flashes at high speed during sending.
- ④ TXD LED : Flashes at high speed during sending.
- ⑤ Connector (9-pin D-SUB type) for peripheral unit  
The top face of this connector is higher than the top face of the panel cover of the programmable controller by approximately 3 mm (0.12") or by approximately 50 mm when the cable is connected.
- ⑥ Mounting holes of connector <math>2 - M2.7 (0.11'') \times 0.635 (0.025'')>

## 2 TERMINAL LAYOUTS

The connector is a 9-pin D-SUB type, and the pin configuration is as shown below.

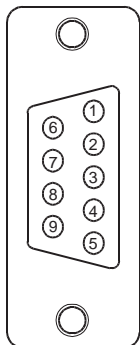

Pin No.	Signal	Meaning	Function
1	CD(DCD)	Carrier detection	ON when carrier is detected for data reception
2	RD(RXD)	Receive data	Receive data (RS232C device to 232BD)
3	SD(TXD)	Send data	Send data (232BD to RS232C device)
4	ER(DTR)	Send request	Signal requesting preparation for data sending to RS232C device
5	SG(GND)	Signal ground	Signal ground
6	DR(DSR)	Send enable	Shows RS232C device is ready to receive
7,8,9	NC	No connection	

### 3.1 General specification

General specifications is same as those for the FX<sub>2N</sub> series programmable controller.

### 3.2 Power supply specification

5 V DC, 60 mA is required from the programmable controller.

### 3.3 Specification

<b>Transmission standard</b>	Conforming to RS232C
<b>Transmission distance</b>	Max. 15m
<b>Connector</b>	9-pin D-SUB type
<b>Pin layout of connector</b>	1:CD(DCD) 2:RD(RXD) 3:SD(TXD) 4:ER(DTR) 5:SG(GND) 6:DR(DSR) 7,8,9:NC(No connection)
<b>LED indicators</b>	RXD, TXD
<b>Communication method</b>	Half-duplex communication system
<b>Protocol</b>	Programming protocol, dedicated protocol (format 1 or 4), non protocol
<b>Isolation</b>	No isolation

### 3.4 Related flag and data registers

Diagnostic devices	Operation	Diagnostic devices	Operation
<b>M8121</b>	Data transmission delayed (RS instruction)	<b>D8120</b>	Communications format (RS instruction, dedicated protocol)
<b>M8122</b>	Data transmission flag (RS instruction)	<b>D8121</b>	Local station number (dedicated protocol)
<b>M8123</b>	Finished receiving data (RS instruction)	<b>D8122</b>	Amount of data to be transmitted (RS instruction)
<b>M8124</b>	Carrier detection flag (RS instruction)	<b>D8123</b>	Amount of remaining data already received (RS instruction)
<b>M8126</b>	Global flag (dedicated protocol)	<b>D8124</b>	Data header <default STX (02H)> (RS instruction)
<b>M8127</b>	On demand handshake flag (dedicated protocol)	<b>D8125</b>	Data terminator <default ETX (03H)> (RS instruction)
<b>M8128</b>	On demand error flag (dedicated protocol)	<b>D8127</b>	On demand head device register (dedicated protocol)
<b>M8129</b>	On demand Byte/Word flag (dedicated protocol)	<b>D8128</b>	On demand data length register (dedicated protocol)
<b>M8161</b>	Selection of 8 bit operations for applied instructions ASC, RS, ASCII, HEX, CCD (RS instruction)	<b>D8129</b>	Data network 'time-out' timer value (dedicated protocol)

### 3.5 Communication format D8120

To send and receive the data between the RS232C unit using the 232BD, the communication format including the transmission speed (baud rate) and the parity must be consistent between the 232BD and the RS232C unit. The communication format can be set using parameters or the contents of special data register D8120 of the FX<sub>2N</sub> programmable controller. Make sure to set appropriately the communication format in accordance with the RS232C unit used. For the setting method using the parameters of the FX<sub>2N</sub> programmable controller, refer to the manual of the peripheral unit used.

Make sure to turn off the power of the programmable controller and turn it on again after modifying the setting.

Bit No.	Meaning	Contents	
		0 (OFF)	1 (ON)
<b>b0</b>	Data length	7 bit	8 bit
<b>b1</b> <b>b2</b>	Parity	b2,b1 (0, 0) : None (0, 1) : Odd	b2,b1 (1, 1) : Even
<b>b3</b>	Stop bit	1 bit	2 bit
<b>b4</b> <b>b5</b> <b>b6</b> <b>b7</b>	Baud rate (bps)	b7,b6,b5,b4 (0, 0, 1, 1) : 300 (0, 1, 0, 0) : 600 (0, 1, 0, 1) : 1,200 (0, 1, 1, 0) : 2,400	b7,b6,b5,b4 (0, 1, 1, 1) : 4,800 (1, 0, 0, 0) : 9,600 (1, 0, 0, 1) : 19,200

Bit No.	Meaning	Contents	
		0 (OFF)	1 (ON)
<b>b8</b>	Header character *1	None	D8124 *2
<b>b9</b>	Terminator character *1	None	D8125 *3
<b>b10</b>	Reserved		
<b>b11</b>	DTR check (Control line) *4	Send and receive	Receive
<b>b12</b>	Control line *4	None	H / W
<b>b13</b>	Sum check *5	Sum check code is not added	Sum check code is added automatically
<b>b14</b>	Protocol	No protocol	Dedicated protocol
<b>b15</b>	Transmission control protocol *5	Protocol format 1	Protocol format 4

\*1 Set to "0" when using the dedicated protocol.

\*2 Effective only when no protocol (RS instruction) is selected, and has an initial value of STX (02H: Can be modified by the user).

\*3 Effective only when no protocol (RS instruction) is selected, and has an initial value of ETX (03H: Can be modified by the user).

\*4 Set to (b11, b12) = (1, 0) when using the dedicated protocol.

\*5 Set to "0" when using no protocol.

#### 3.5.1 Example program of setting

The communication format is set by special data register D8120. Setting the communication format using D8120 is effective only at the time the RS instruction is driven, and therefore if changed after driving, it is not actually accepted.

An example of setting D8120 is shown below.

M8002	MOV	H138F	D8120
-------	-----	-------	-------

H138F = 0001 0011 1000 1111(binary)

The settings for the above program are as right.

<b>Data length</b>	8 bit
<b>Parity</b>	Even
<b>Stop bit</b>	2 bit
<b>Baud rate</b>	9,600
<b>Protocol</b>	No protocol
<b>Header</b>	Used
<b>Terminator</b>	Used
<b>Control line</b>	H / W
<b>DTR check</b>	Send and receive

The control line is set by b12.

b12 = 0 : No hardware hand shaking. Send and receive are controlled by software protocol.

b12 = 1 : Hardware hand shaking. Signal lines ER(DTR)and DR(DSR)are used to control send and receive of data.

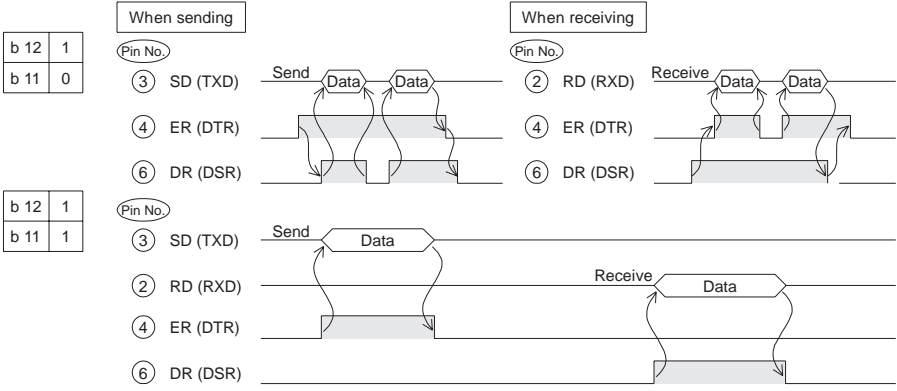

## 4

## WIRING

To connect the 232BD to RS232C device use an RS232C cable. Make sure that the shield of cables is connected to ground (100 Ω or less).

The connector of the 232BD is 9-pin D-SUB (see Section 1.2 and Chapter 2). The connections of RS232C devices varies with each device being used. Check the specification of the device, and connect.

### 4.1 Connection examples

#### 4.1.1 Terminal specification device

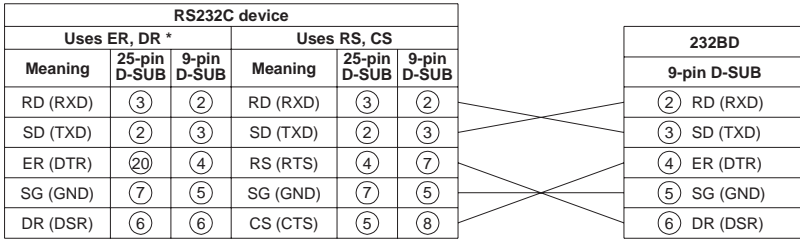

\* When using ER and DR signals, please also check if RS and CS signals are needed according to the RS232C device's specifications.

#### 4.1.2 Modem specification device

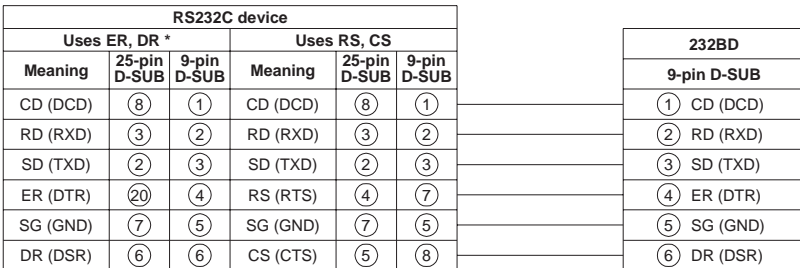

\* When using ER and DR signals, please also check if RS and CS signals are needed according to the RS232C device's specifications.

#### 4.1.3 When programming or monitoring

Use F2-232CAB-1 and 25-pin D-SUB to 9-pin D-SUB adapter or make a suitable cable.

## 5

## MOUNTING PROCEDURE

Turn off the power of the programmable controller, and mount the 232BD using the following procedure.

- Remove the panel cover from the top face of the main unit.
- Connect the 232BD to the board mounting connector provided on the base unit.
- Fix the 232BD to the main unit using the M3 self-tapping screws provided, fitting the mounting bracket and the round crimp-style terminal with the ground cable as shown in the figure on the right. Make sure that the crimp-style terminal is attached in the direction shown in the figure on the right, and that the ground cable extends from the unit shown in the figure below. Tightening torque: 0.3 to 0.6 Nm (3 to 6 kgf·cm)

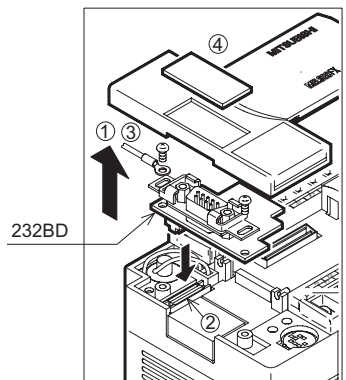
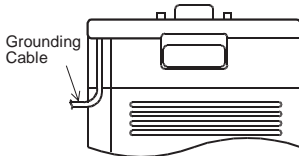
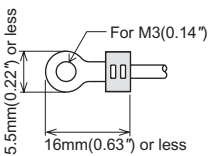

- Cut out the hole provided on the left portion of the panel cover using a tool such as nippers and cutter so that the terminal block can be seen. The top face of this connector is higher than the top face of the panel cover of the programmable controller by approximately 7 mm (0.27").

- 1) When programming tool is connected to the 232BD, do not use any other communication format or parameters. If communication format or parameters is set, programming is not possible.
- 2) Only one programming tool (such as FX-10P, FX-20P, etc.) should be connected to either the programming port or the port provided on the 232BD. If a programming tool is connected to both connectors, the following may occur.
  - a) The program inside the programmable controller may not be consistent with the program inside the programming tool. If the program is modified or the set value for the timer or the counter is modified, a part of the program may be damaged and the programmable controller may malfunction.
  - b) When the sampling trace function of the programmable controller is used from both ports, the correct sampling trace result cannot be obtained.

- 1) Connecting 232BD and a printer, and printing out the data sent from the PC.

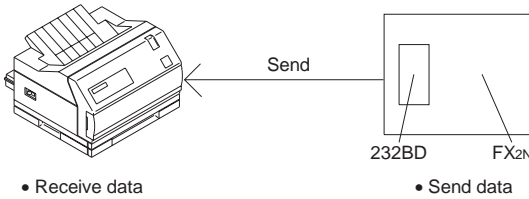

- The communication format of the serial printer is as follows.

<b>Data length</b>	8 bit
<b>Parity</b>	Even
<b>Stop bit</b>	1 bit
<b>Baud rate</b>	2400 bps

#### Sequence program

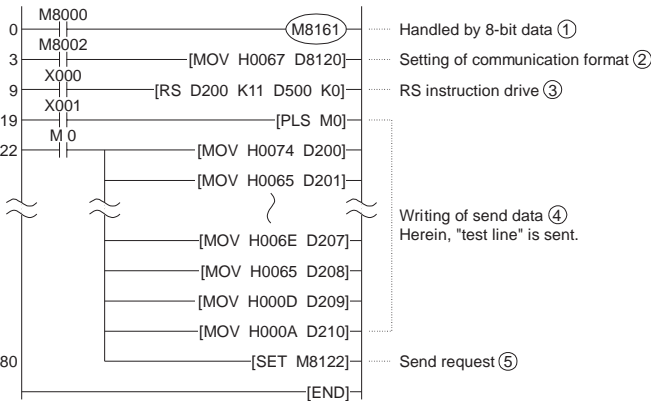

#### Operation

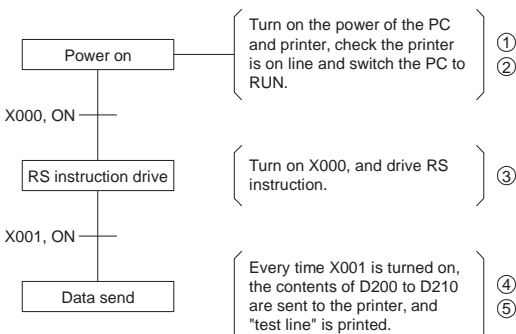

- In this example, CR (H000D) and LF (H000A) are written at the end of the message. The printer moves down one line for each message.

CR : Carriage Return

LF : Line Feed

Note: It may be necessary to set the DIP switches of your printer. Check your printer manual for how to configure the serial communications.

2) Connect 232BD and a personal computer, and exchange data with PC.

Preparation of software

- Use ordinary communication software (terminal emulator) or dedicated program in the personal computer.

The communication format of the PC for this example is as follows.

<b>Data length</b>	8 bit
<b>Parity</b>	Even
<b>Stop bit</b>	1 bit
<b>Baud rate</b>	2400

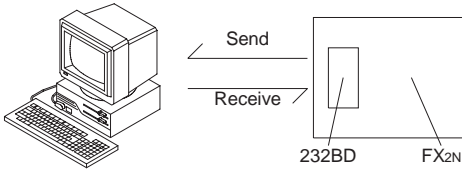

- Receive data
- Send data
- Send data
- Receive data
- Use the communication cable suited to the connector pin configuration of the personal computer. (For representative wiring see section 4.)

If the communication format of the software cannot be adjusted to this setting, adjust the PC and the software to be the same.

Sequence program

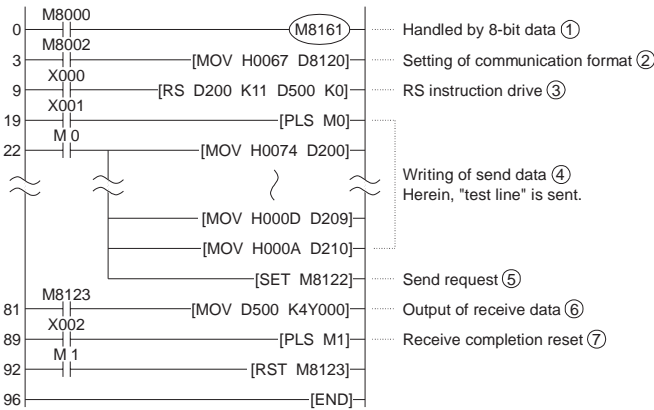

Operation

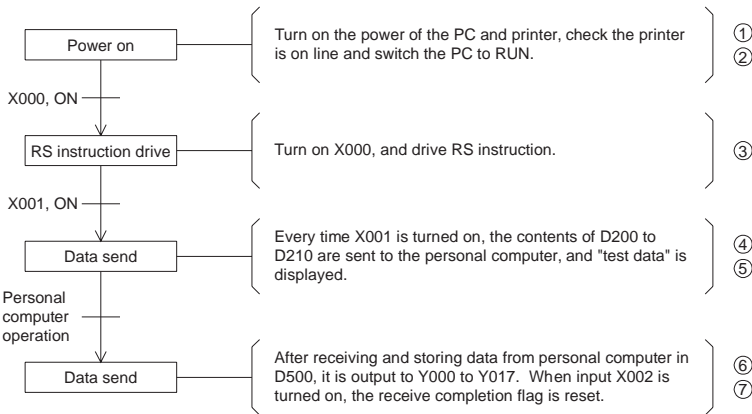

# 8 DIAGNOSTICS

**8.1 Common items**

- 1) Make sure that the programmable controller is connected and that the POWER LED is lighted on the programmable controller.
- 2) Make sure that the VRRD or VRSC instruction is not used in the program. If such an instruction is used, delete it, turn off the power of the programmable controller, then turn it on again.
- 3) When the special auxiliary relay M8070 or M8071 is turned on, turn off the relay using the peripheral unit, turn off the power of the programmable controller, then turn on the power again.
- 4) Make sure that wiring is performed correctly. Refer to Section 4.
- 5) Make sure using the peripheral unit that the communication parameters are set correctly in accordance with the application. If the setting is not correct, set the parameters correctly using the peripheral unit.

**8.2 When the parallel link function is used**

- 1) Make sure that the communication format is in the initial state (D8120 = K0). Check using the peripheral unit how the communication parameters are set. If the no protocol (RS instruction) or the dedicated protocol is selected, set the parameters correctly using the peripheral unit.
- 2) If the RS instruction is used in the program, delete it, turn off the power of the programmable controller, then turn it on again.

### 8.3 When communication is performed between the computer using the no protocol

- 1) Make sure that the communication format is consistent between the external unit (RS232C unit) and the programmable controller (D8120). If it is not consistent, correct the setting of the communication parameters or correct the contents of the D8120. When the D8120 is modified, turn on the RS instruction again. When the communication parameters are modified, turn off the power of the programmable controller, then turn it on again.
- 2) Check the timing for sending and receiving the data. For example, confirm that the counterpart unit is ready for receiving before sending the data.
- 3) If a terminator is not used, make sure that the send data quantity is consistent with the receivable data quantity. If both quantities are not consistent with each other, make them be consistent. (If the send data quantity varies, use a terminator.)
- 4) Make sure that the external unit is operating correctly.
- 5) Make sure that the data format transferred is equivalent. If it is not equivalent, correct it.
- 6) When the RS instruction is used twice or more in the program, make sure that only one RS instruction is turned on in one calculation cycle. Never set the RS instruction to OFF state while the data is being received or sent.

### 8.4 When the dedicated protocol is used for communication between the computer

- 1) Make sure that the communication format is consistent between the computer (RS232C unit) and the programmable controller (D8120). If it is not consistent, correct the setting of either the computer or the programmable controller. When the programmable controller is modified, turn off the power of the programmable controller, then turn it on again.
- 2) Make sure that the station No. of the programmable controller which is the target of data transfer is equivalent to the station No. set in the communication procedure. If they are not equivalent, correct the wrong one.
- 3) Make sure that the communication procedure is correct. If it is not correct, modify the setting of the RS232 unit to realize correct procedure.
- 4) Check whether errors have occurred in the RS232 unit and the programmable controller. For the check method and the countermeasures, refer to the users manual of the FX-485PC-IF.
- 5) If the RS instruction is used in the program, delete it, turn off the power of the programmable controller, then turn it on again.

#### Guidelines for the safety of the user and protection of the FX<sub>2N</sub>-232-BD

- This manual has been written to be used by trained and competent personnel. This is defined by the European directives for machinery, low voltage and EMC.
- If in doubt at any stage during the installation of the FX<sub>2N</sub>-232-BD always consult a professional electrical engineer who is qualified and trained to the local and national standards. If in doubt about the operation or use of the FX<sub>2N</sub>-232-BD please consult the nearest Mitsubishi Electric distributor.
- Under no circumstances will Mitsubishi Electric be liable or responsible for any consequential damage that may arise as a result of the installation or use of this equipment.
- All examples and diagrams shown in this manual are intended only as an aid to understanding the text, not to guarantee operation. Mitsubishi Electric will accept no responsibility for actual use of the product based on these illustrative examples.
- Owing to the very great variety in possible application of this equipment, you must satisfy yourself as to its suitability for your specific application.

Manual number : JY992D66001

Manual revision : A

Date : JUNE 1997

 **MITSUBISHI ELECTRIC CORPORATION**

HEAD OFFICE: MITSUBISHI DENKI BLDG MARUNOUCHI TOKYO 100 TELEX: J24532 CABLE MELCO TOKYO  
HIMEJI WORKS: 840, CHIYODA CHO, HIMEJI, JAPAN



# FX<sub>2N</sub>

## FX<sub>2N</sub>-232-BD COMMUNICATION BOARD

### USER'S GUIDE

JY992D66001A

This manual contains text, diagrams and explanations which will guide the reader in the correct installation and operation of the FX<sub>2N</sub>-232-BD and should be read and understood before attempting to install or use the unit. Further information can be found in the FX SERIES PROGRAMMING MANUAL, FX<sub>2N</sub> SERIES HARDWARE MANUAL and FX-485PC-IF USER'S MANUAL.

## 1 INTRODUCTION

The communication board FX<sub>2N</sub>-232-BD for RS232C (hereinafter referred to as "232BD") can be connected to the main unit of the FX<sub>2N</sub> Series programmable controller, and used as the port for the following applications.

- To perform data transfer between RS232C devices such as personal computers, bar code readers and printers.
- To perform data transfer using the dedicated protocol between RS232C devices. For details of the dedicated protocol, refer to the users manual of the FX-485PC-IF.
- To connect a programming tool.

And when the 232BD is used for the application (1) or (2) above, the communication format including the baud rate, the parity and the data length is specified by the parameters or the contents of the special data register D8120 of the FX<sub>2N</sub> programmable controller.

Only one 232BD can be connected to one base unit. Accordingly, the 232BD cannot be used together with the FX<sub>2N</sub>-485-BD or the FX<sub>2N</sub>-422-BD. When two or more RS232C units are required to be connected for the application, use the special block for RS232C communication.

### 1.1 EXTERNAL DIMENSIONS

Dimensions : mm (inches) Accessory : M3 self-tapping screws × 2, mounting bracket × 2

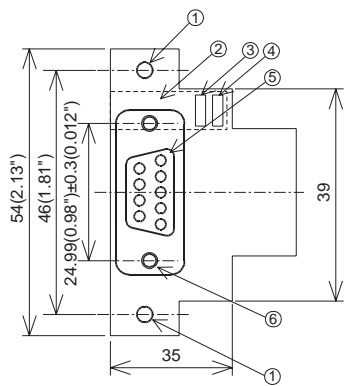

- Mounting holes <math>2\text{-}\phi 4.0 (0.16'')>
- Connector for programmable controller
- RXD LED : Flashes at high speed during sending.
- TXD LED : Flashes at high speed during sending.
- Connector (9-pin D-SUB type) for peripheral unit  
The top face of this connector is higher than the top face of the panel cover of the programmable controller by approximately 3 mm (0.12") or by approximately 50 mm when the cable is connected.
- Mounting holes of connector <math>2\text{-} M2.7 (0.11'') \times 0.635 (0.025'')>

## 2 TERMINAL LAYOUTS

The connector is a 9-pin D-SUB type, and the pin configuration is as shown below.

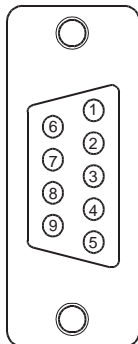

Pin No.	Signal	Meaning	Function
1	CD(DCD)	Carrier detection	ON when carrier is detected for data reception
2	RD(RXD)	Receive data	Receive data (RS232C device to 232BD)
3	SD(TXD)	Send data	Send data (232BD to RS232C device)
4	ER(DTR)	Send request	Signal requesting preparation for data sending to RS232C device
5	SG(GND)	Signal ground	Signal ground
6	DR(DSR)	Send enable	Shows RS232C device is ready to receive
7,8,9	NC	No connection	

## 3 SPECIFICATION

### 3.1 General specification

General specifications is same as those for the FX<sub>2N</sub> series programmable controller.

### 3.2 Power supply specification

5 V DC, 60 mA is required from the programmable controller.

### 3.3 Specification

<b>Transmission standard</b>	Conforming to RS232C
<b>Transmission distance</b>	Max. 15m
<b>Connector</b>	9-pin D-SUB type
<b>Pin layout of connector</b>	1:CD(DCD) 2:RD(RXD) 3:SD(TXD) 4:ER(DTR) 5:SG(GND) 6:DR(DSR) 7,8,9:NC(No connection)
<b>LED indicators</b>	RXD, TXD
<b>Communication method</b>	Half-duplex communication system
<b>Protocol</b>	Programming protocol, dedicated protocol (format 1 or 4), non protocol
<b>Isolation</b>	No isolation

### 3.4 Related flag and data registers

Diagnostic devices	Operation	Diagnostic devices	Operation
<b>M8121</b>	Data transmission delayed (RS instruction)	<b>D8120</b>	Communications format (RS instruction, dedicated protocol)
<b>M8122</b>	Data transmission flag (RS instruction)	<b>D8121</b>	Local station number (dedicated protocol)
<b>M8123</b>	Finished receiving data (RS instruction)	<b>D8122</b>	Amount of data to be transmitted (RS instruction)
<b>M8124</b>	Carrier detection flag (RS instruction)	<b>D8123</b>	Amount of remaining data already received (RS instruction)
<b>M8126</b>	Global flag (dedicated protocol)	<b>D8124</b>	Data header <default STX (02H)> (RS instruction)
<b>M8127</b>	On demand handshake flag (dedicated protocol)	<b>D8125</b>	Data terminator <default ETX (03H)> (RS instruction)
<b>M8128</b>	On demand error flag (dedicated protocol)	<b>D8127</b>	On demand head device register (dedicated protocol)
<b>M8129</b>	On demand Byte/Word flag (dedicated protocol)	<b>D8128</b>	On demand data length register (dedicated protocol)
<b>M8161</b>	Selection of 8 bit operations for applied instructions ASC, RS, ASCII, HEX, CCD (RS instruction)	<b>D8129</b>	Data network 'time-out' timer value (dedicated protocol)

### 3.5 Communication format D8120

To send and receive the data between the RS232C unit using the 232BD, the communication format including the transmission speed (baud rate) and the parity must be consistent between the 232BD and the RS232C unit. The communication format can be set using parameters or the contents of special data register D8120 of the FX<sub>2N</sub> programmable controller. Make sure to set appropriately the communication format in accordance with the RS232C unit used. For the setting method using the parameters of the FX<sub>2N</sub> programmable controller, refer to the manual of the peripheral unit used. Make sure to turn off the power of the programmable controller and turn it on again after modifying the setting.

Bit No.	Meaning	Contents	
		0 (OFF)	1 (ON)
<b>b0</b>	Data length	7 bit	8 bit
<b>b1</b>	Parity	b2,b1 (0, 0) : None (0, 1) : Odd	b2,b1 (1, 1) : Even
<b>b3</b>	Stop bit	1 bit	2 bit
<b>b4</b>	Baud rate (bps)	b7,b6,b5,b4 (0, 0, 1, 1) : 300	b7,b6,b5,b4 (0, 1, 1, 1) : 4,800
<b>b5</b>		(0, 1, 0, 0) : 600	(1, 0, 0, 0) : 9,600
<b>b6</b>		(0, 1, 0, 1) : 1,200	(1, 0, 0, 1) : 19,200
<b>b7</b>		(0, 1, 1, 0) : 2,400	

Bit No.	Meaning	Contents	
		0 (OFF)	1 (ON)
<b>b8</b>	Header character *1	None	D8124 *2
<b>b9</b>	Terminator character *1	None	D8125 *3
<b>b10</b>	Reserved		
<b>b11</b>	DTR check (Control line) *4	Send and receive	Receive
<b>b12</b>	Control line *4	None	H / W
<b>b13</b>	Sum check *5	Sum check code is not added	Sum check code is added automatically
<b>b14</b>	Protocol	No protocol	Dedicated protocol
<b>b15</b>	Transmission control protocol *5	Protocol format 1	Protocol format 4

\*1 Set to "0" when using the dedicated protocol.

\*2 Effective only when no protocol (RS instruction) is selected, and has an initial value of STX (02H: Can be modified by the user).

\*3 Effective only when no protocol (RS instruction) is selected, and has an initial value of ETX (03H: Can be modified by the user).

\*4 Set to (b11, b12) = (1, 0) when using the dedicated protocol.

\*5 Set to "0" when using no protocol.

### 3.5.1 Example program of setting

The communication format is set by special data register D8120. Setting the communication format using D8120 is effective only at the time the RS instruction is driven, and therefore if changed after driving, it is not actually accepted.

An example of setting D8120 is shown below.



H138F = 0001 0011 1000 1111(binary)

The settings for the above program are as right.

<b>Data length</b>	8 bit
<b>Parity</b>	Even
<b>Stop bit</b>	2 bit
<b>Baud rate</b>	9,600
<b>Protocol</b>	No protocol
<b>Header</b>	Used
<b>Terminator</b>	Used
<b>Control line</b>	H / W
<b>DTR check</b>	Send and receive

The control line is set by b12.

b12 = 0 : No hardware hand shaking. Send and receive are controlled by software protocol.

b12 = 1 : Hardware hand shaking. Signal lines ER(DTR)and DR(DSR)are used to control send and receive of data.

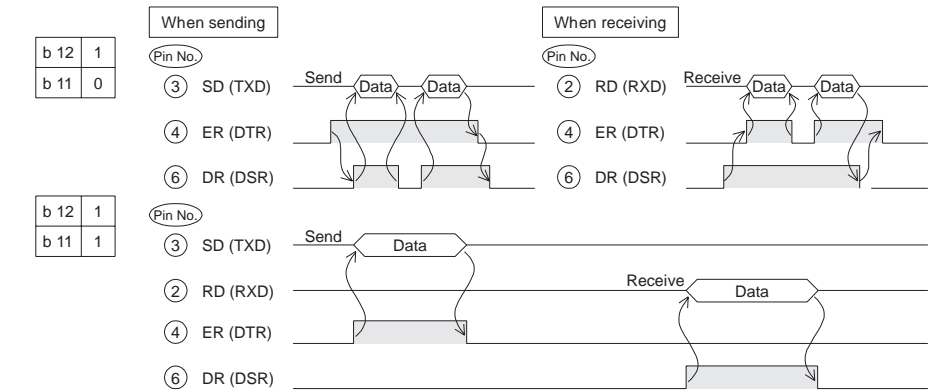

## 4 WIRING

To connect the 232BD to RS232C device use an RS232C cable. Make sure that the shield of cables is connected to ground (100 Ω or less).

The connector of the 232BD is 9-pin D-SUB (see Section 1.2 and Chapter 2). The connections of RS232C devices varies with each device being used. Check the specification of the device, and connect.

### 4.1 Connection examples

#### 4.1.1 Terminal specification device

RS232C device						232BD	
Uses ER, DR *			Uses RS, CS			9-pin D-SUB	
Meaning	25-pin D-SUB	9-pin D-SUB	Meaning	25-pin D-SUB	9-pin D-SUB		
RD (RXD)	③	②	RD (RXD)	③	②	②	RD (RXD)
SD (TXD)	②	③	SD (TXD)	②	③	③	SD (TXD)
ER (DTR)	⑳	④	RS (RTS)	④	⑦	④	ER (DTR)
SG (GND)	⑦	⑤	SG (GND)	⑦	⑤	⑤	SG (GND)
DR (DSR)	⑥	⑥	CS (CTS)	⑤	⑧	⑥	DR (DSR)

\* When using ER and DR signals, please also check if RS and CS signals are needed according to the RS232C device's specifications.

#### 4.1.2 Modem specification device

RS232C device						232BD	
Uses ER, DR *			Uses RS, CS			9-pin D-SUB	
Meaning	25-pin D-SUB	9-pin D-SUB	Meaning	25-pin D-SUB	9-pin D-SUB		
CD (DCD)	⑧	①	CD (DCD)	⑧	①	①	CD (DCD)
RD (RXD)	③	②	RD (RXD)	③	②	②	RD (RXD)
SD (TXD)	②	③	SD (TXD)	②	③	③	SD (TXD)
ER (DTR)	⑳	④	RS (RTS)	④	⑦	④	ER (DTR)
SG (GND)	⑦	⑤	SG (GND)	⑦	⑤	⑤	SG (GND)
DR (DSR)	⑥	⑥	CS (CTS)	⑤	⑧	⑥	DR (DSR)

\* When using ER and DR signals, please also check if RS and CS signals are needed according to the RS232C device's specifications.

#### 4.1.3 When programming or monitoring

Use F2-232CAB-1 and 25-pin D-SUB to 9-pin D-SUB adapter or make a suitable cable.

## 5 MOUNTING PROCEDURE

Turn off the power of the programmable controller, and mount the 232BD using the following procedure.

- Remove the panel cover from the top face of the main unit.
- Connect the 232BD to the board mounting connector provided on the base unit.
- Fix the 232BD to the main unit using the M3 self-tapping screws provided, fitting the mounting bracket and the round crimp-style terminal with the ground cable as shown in the figure on the right. Make sure that the crimp-style terminal is attached in the direction shown in the figure on the right, and that the ground cable extends from the unit shown in the figure below. Tightening torque: 0.3 to 0.6 Nm (3 to 6 kgf-cm)

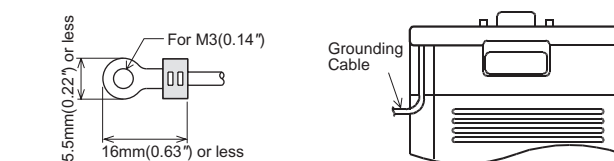

- Cut out the hole provided on the left portion of the panel cover using a tool such as nippers and cutter so that the terminal block can be seen. The top face of this connector is higher than the top face of the panel cover of the programmable controller by approximately 7 mm (0.27").

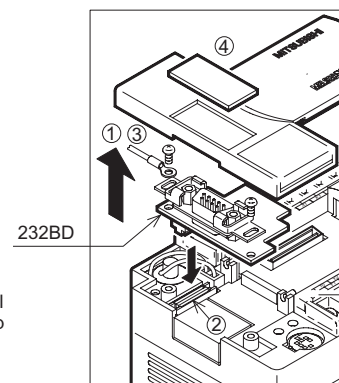

## 6 CAUTION FOR USE

- When programming tool is connected to the 232BD, do not use any other communication format or parameters. If communication format or parameters is set, programming is not possible.
- Only one programming tool (such as FX-10P, FX-20P, etc.) should be connected to either the programming port or the port provided on the 232BD. If a programming tool is connected to both connectors, the following may occur.
  - The program inside the programmable controller may not be consistent with the program inside the programming tool. If the program is modified or the set value for the timer or the counter is modified, a part of the program may be damaged and the programmable controller may malfunction.
  - When the sampling trace function of the programmable controller is used from both ports, the correct sampling trace result cannot be obtained.

- Connect 232BD and a personal computer, and exchange data with PC.

### Preparation of software

- Use ordinary communication software (terminal emulator) or dedicated program in the personal computer.

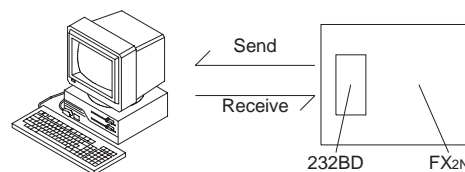

- Receive data
- Send data

The communication format of the PC for this example is as follows.

Data length	8 bit
Parity	Even
Stop bit	1 bit
Baud rate	2400

- Use the communication cable suited to the connector pin configuration of the personal computer. (For representative wiring see section 4.)

If the communication format of the software cannot be adjusted to this setting, adjust the PC and the software to be the same.

### 8.3 When communication is performed between the computer using the no protocol

- Make sure that the communication format is consistent between the external unit (RS232C unit) and the programmable controller (D8120). If it is not consistent, correct the setting of the communication parameters or correct the contents of the D8120. When the D8120 is modified, turn on the RS instruction again. When the communication parameters are modified, turn off the power of the programmable controller, then turn it on again.
- Check the timing for sending and receiving the data. For example, confirm that the counterpart unit is ready for receiving before sending the data.
- If a terminator is not used, make sure that the send data quantity is consistent with the receivable data quantity. If both quantities are not consistent with each other, make them be consistent. (If the send data quantity varies, use a terminator.)
- Make sure that the external unit is operating correctly.
- Make sure that the data format transferred is equivalent. If it is not equivalent, correct it.
- When the RS instruction is used twice or more in the program, make sure that only one RS instruction is turned on in one calculation cycle. Never set the RS instruction to OFF state while the data is being received or sent.

## 7 PROGRAM EXAMPLES

- Connecting 232BD and a printer, and printing out the data sent from the PC.

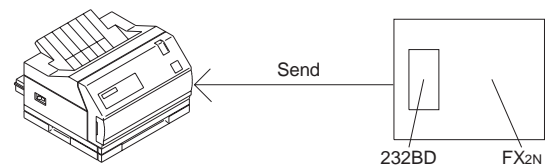

- Receive data
  - Send data
- The communication format of the serial printer is as follows.

Data length	8 bit
Parity	Even
Stop bit	1 bit
Baud rate	2400 bps

### Sequence program

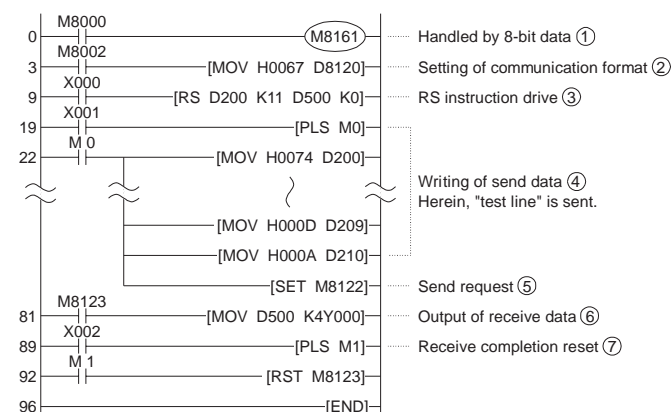

### 8.4 When the dedicated protocol is used for communication between the computer

- Make sure that the communication format is consistent between the computer (RS232C unit) and the programmable controller (D8120). If it is not consistent, correct the setting of either the computer or the programmable controller. When the programmable controller is modified, turn off the power of the programmable controller, then turn it on again.
- Make sure that the station No. of the programmable controller which is the target of data transfer is equivalent to the station No. set in the communication procedure. If they are not equivalent, correct the wrong one.
- Make sure that the communication procedure is correct. If it is not correct, modify the setting of the RS232 unit to realize correct procedure.
- Check whether errors have occurred in the RS232 unit and the programmable controller. For the check method and the countermeasures, refer to the users manual of the FX-485PC-IF.
- If the RS instruction is used in the program, delete it, turn off the power of the programmable controller, then turn it on again.

### Sequence program

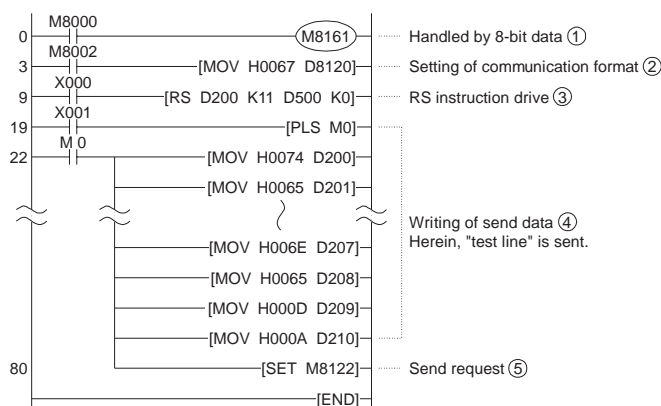

### Operation

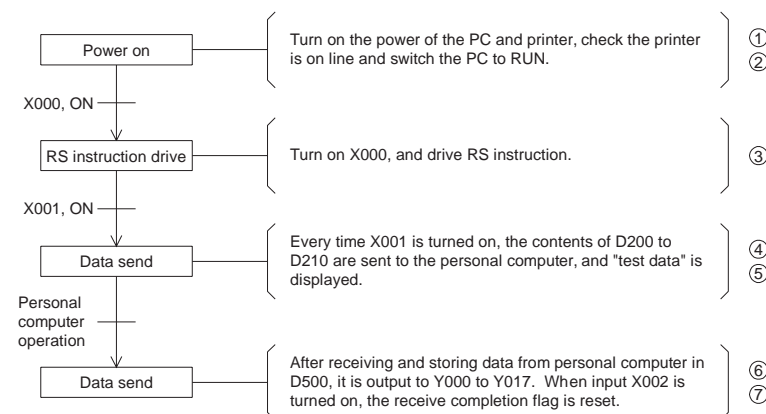

### Guidelines for the safety of the user and protection of the FX2N-232-BD

- This manual has been written to be used by trained and competent personnel. This is defined by the European directives for machinery, low voltage and EMC.
- If in doubt at any stage during the installation of the FX2N-232-BD always consult a professional electrical engineer who is qualified and trained to the local and national standards. If in doubt about the operation or use of the FX2N-232-BD please consult the nearest Mitsubishi Electric distributor.
- Under no circumstances will Mitsubishi Electric be liable or responsible for any consequential damage that may arise as a result of the installation or use of this equipment.
- All examples and diagrams shown in this manual are intended only as an aid to understanding the text, not to guarantee operation. Mitsubishi Electric will accept no responsibility for actual use of the product based on these illustrative examples.
- Owing to the very great variety in possible application of this equipment, you must satisfy yourself as to its suitability for your specific application.

### Operation

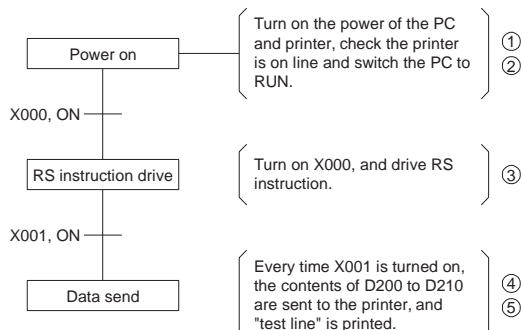

- In this example, CR (H000D) and LF (H000A) are written at the end of the message. The printer moves down one line for each message.  
CR : Carriage Return  
LF : Line Feed

Note: It may be necessary to set the DIP switches of your printer. Check your printer manual for how to configure the serial communications.

## 8 DIAGNOSTICS

### 8.1 Common items

- Make sure that the programmable controller is connected and that the POWER LED is lighted on the programmable controller.
- Make sure that the VRRD or VRSC instruction is not used in the program. If such an instruction is used, delete it, turn off the power of the programmable controller, then turn it on again.
- When the special auxiliary relay M8070 or M8071 is turned on, turn off the relay using the peripheral unit, turn off the power of the programmable controller, then turn on the power again.
- Make sure that wiring is performed correctly. Refer to Section 4.
- Make sure using the peripheral unit that the communication parameters are set correctly in accordance with the application. If the setting is not correct, set the parameters correctly using the peripheral unit.

### 8.2 When the parallel link function is used

- Make sure that the communication format is in the initial state (D8120 = K0). Check using the peripheral unit how the communication parameters are set. If the no protocol (RS instruction) or the dedicated protocol is selected, set the parameters correctly using the peripheral unit.
- If the RS instruction is used in the program, delete it, turn off the power of the programmable controller, then turn it on again.

Manual number : JY992D66001  
Manual revision : A  
Date : JUNE 1997

**MITSUBISHI ELECTRIC CORPORATION**  
HEAD OFFICE: MITSUBISHI DENKI BLDG MARUNOUCHI TOKYO 100 TELEX: J24532 CABLE MELCO TOKYO  
HIMEJI WORKS: 840, CHIYODA CHO, HIMEJI, JAPAN