

**MELSEC
FX1S
FX1N
FX2N**

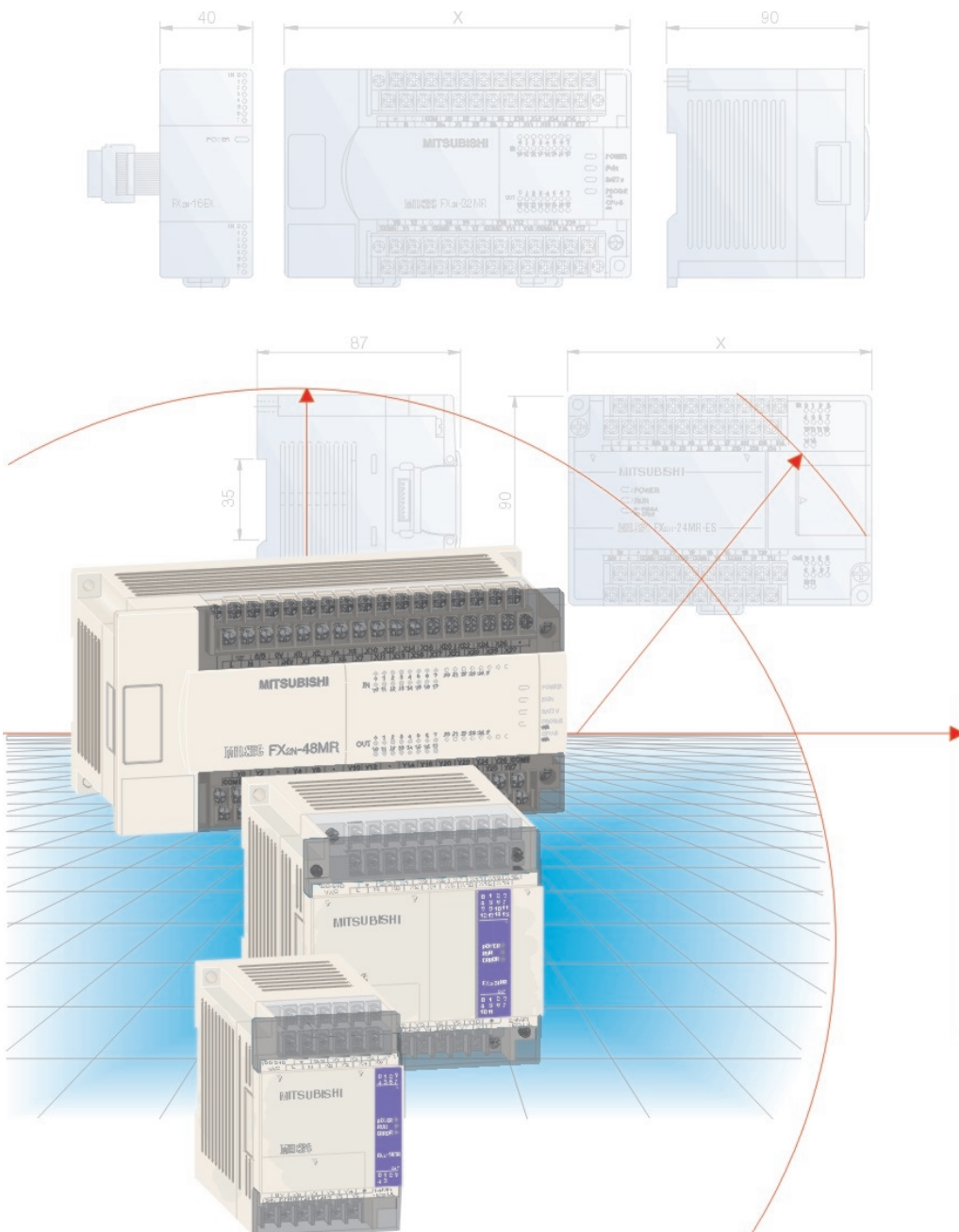

Technical Catalogue

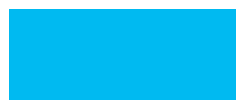

New Items in this Catalogue

New Products 2002



MELSEC FX1S

The range of base units has been extended by 4 modules with transistor outputs and a power supply of 100–240 V AC.

For the FX1S the alarm and remote control system FX1S Messenger for wireless telephony via GSM is available.



MELSEC FX1N

The range of FX1N base units has been extended as well by 4 modules with transistor outputs and a power supply of 100–240 V AC.

For the application in the FX1S and FX1N controllers new adapters are available:

- Extension adapter board FX1N-4EX-BD with 4 digital inputs
- Extension adapter board FX1N-2EYT-BD with 2 transistor outputs
- Analog adapter board FX1N-2AD-BD for 2 channel AD conversion
- Analog adapter board FX1N-1DA-BD for 1 channel DA conversion



MELSEC FX2N

The new positioning module FX2N-10PG facilitates the output of up to 1 MHz pulses to control 1-axis servo or stepping motors.

New memory module FX2N-ROM-E1 for an easier communication between PLC and Mitsubishi frequency inverters.

Further Publications within the PLC Range

Technical Catalogues

Q, AnU, QnA, AnS, QnAS Series Technical Catalogues

Product catalogues for programmable logic controllers and accessories for the further MELSEC PLC series

Networks Technical Catalogue

Product catalogue for Master and Slave modules as well as accessories for the use of programmable logic controllers in open and MELSEC networks (art. no. 136730)

HMI Technical Catalogue

Product catalogue for operator terminals, supervision software and accessories (art. no. 68542)

Additional Services

You will find current information on updates, alterations, new items, and technical support on the MITSUBISHI ELECTRIC's web pages (www.mitsubishi-automation.com). The products section of the MITSUBISHI home site includes various documentations of the whole product range by MITSUBISHI ELECTRIC as well as the current version of this catalogue on hand. All manuals and catalogues can be downloaded. The content is updated daily and to date is provided in German and English.

About this product catalogue

Due to the constantly growing product range, technical alteration, and new or changed characteristic features, this catalogue is updated frequently.

Texts, figures and diagrams shown in this product catalogue are intended exclusively for explanation and assistance in planning and ordering the programmable logic controllers of the MELSEC FX1S, FX1N and FX2N series and the associated accessories. Only the manuals supplied with the units are relevant for installation, commissioning and handling of the units and the accessories. The information given in these documentations must be read before installation and commissioning of the units or software.

Should questions arise with regard to the planning of modules described in this product catalogue, do not hesitate to contact the German branch of the MITSUBISHI ELECTRIC EUROPE B.V. in Ratingen or one of its distributors (see cover page).

© MITSUBISHI ELECTRIC EUROPE B.V. 10/2002 (4th edition - version D)

FX FAMILY

SYSTEM DESCRIPTION

- ◆ Introduction of the FX family 4
- ◆ Networks 8

MELSEC FX1S

BASE UNITS

- ◆ Description of system and unit 10
- ◆ Specifications 12

ACCESSORIES

- ◆ Adapter, display module, control panels 14
- ◆ Memory cassette, simulation strip, simulation box, FX1S Messenger 15

TERMINALS AND DIMENSIONS

- ◆ Terminal assignments 16
- ◆ Dimensions 17

MELSEC FX1N/FX2N

SYSTEM DESCRIPTION

- ◆ Base units, possible configurations 18
- ◆ Extension and special function modules 22
- ◆ System specifications 25

BASE UNITS

- ◆ Specifications FX1N 26
- ◆ Specifications FX2N 28

EXTENSION UNITS

- ◆ Compact extension units 32
- ◆ Modular extension units 34
- ◆ Extension adapter boards 36

SPECIAL FUNCTION UNITS

- ◆ Analog modules and adapters, temperature control module 37
- ◆ Counter module, positioning modules 43
- ◆ Interface modules and adapters 46
- ◆ Communications modules and adapters, network modules 47

ACCESSORIES

- ◆ Interface converter, communications modules and adapters 59
- ◆ Memory cassettes, batteries 63
- ◆ Display module, control panels 64
- ◆ Simulation devices, cables 65

TERMINALS AND DIMENSIONS

- ◆ Terminal assignments of the base units 66
- ◆ Terminal assignments of the extension units 71
- ◆ Terminal assignments of the special function units 73
- ◆ Dimensions 79

PROGRAMMING

SOFTWARE AND PROGRAMMING UNITS

- ◆ Software 83
- ◆ Hand-held programming units, cables and EPROM writer 88

APPENDIX

- ◆ Order form 90
- ◆ Index 91



The MELSEC PLC Systems

BASICS

The MELSEC FX Family

The MELSEC FX family includes a very comprehensive range of base and expansion modules, enabling you to configure a customised system tailored to your precise requirements.

Depending on your application and control needs you can choose from the small, attractively-priced, "stand-alone" MELSEC FX1S series, the expandable FX1N series or the more powerful FX2N series.

The FX1N and FX2N series are both a good choice for plant installations because their expansion options enable them to grow with the needs of your application.

Network integration is also supported, making it possible for your FX controllers to communicate with other PLCs, controllers and HMIs. The PLC systems can be configured as local stations in MITSUBISHI networks, and as slave stations in open networks (PROFIBUS/DP).

In addition to this, the controllers of the MELSEC FX1S/FX1N/FX2N series also support integration in multidrop and peer-to-peer network configurations.

All FX systems are members of the great MELSEC family of PLCs, in which all systems are compatible with one another.



Special features:

- Expandable from 10 – 256 I/Os
- Compact, robust design
- Extensive communications support
- Simple installation
- Custom configuration for the needs of existing systems
- Innovative, "future-proof" technology protects your investment
- Worldwide standards
- Quality products manufactured in facilities with ISO 9001 certified quality management systems and subject to special manufacturers' standards

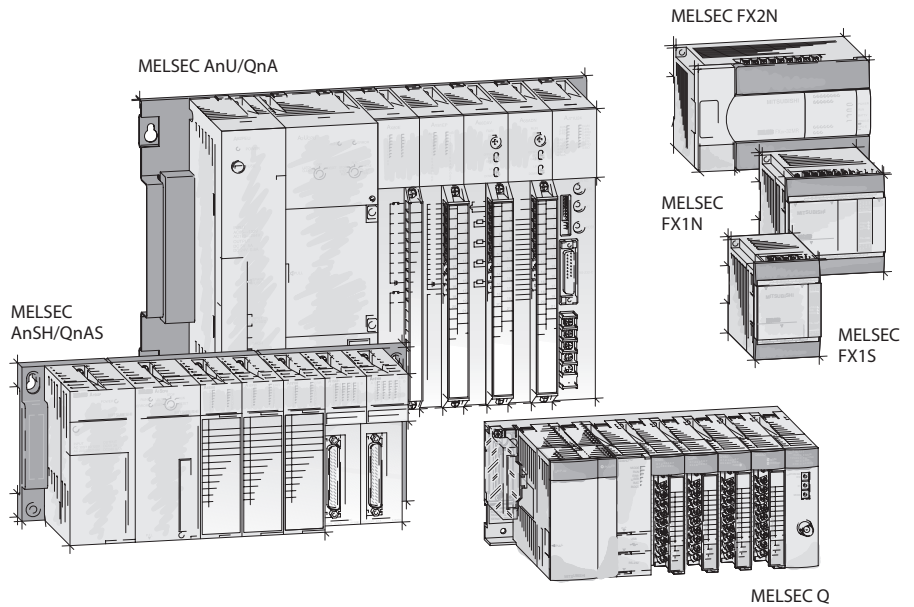

Expandability and Power

The MELSEC FX family is highly flexible, enabling fast and efficient configuration and programming for the application at hand.

It is the ideal choice, no matter whether you need to install a simple control application requiring up to 34 I/Os (FX1S) or a demanding, complex system with up to 256 I/O points (FX2N).

The capacity of the CPUs of the FX1S/FX1N/FX2N series can be expanded with memory cassettes. Non-volatile memory cassettes with a capacity of up to 16 K program steps are available for reliable, long-term storage of your PLC projects. In addition to the other advantages this enables you to switch programs at very short notice, simply by replacing a cassette.



There are three series in the MELSEC FX family, each of which is designed for a different application profile:

● The FX1S series

The MELSEC FX1S series is the inexpensive entry to the MELSEC FX family. With its small dimensions it is also an excellent alternative to relay/contact control configurations.

● The FX1N series

The CPUs of the FX1N series offer more power than the FX1S series, plus modular expansion capabilities. You can choose from I/O expansion modules and special function modules for a wide variety of applications.

● The FX2N series

The FX2N series complements the existing FX family. It gives you the freedom of modular expandability, with a wide selection of expansion modules and special function modules.

The FX2N is also one of the fastest PLC systems available, with a cycle time of just 0,08 µs per logical instruction.

Thus the FX2N series gives you the most powerful CPU for your application and combines all benefits of a compact PLC system with the performance of a modular PLC system.

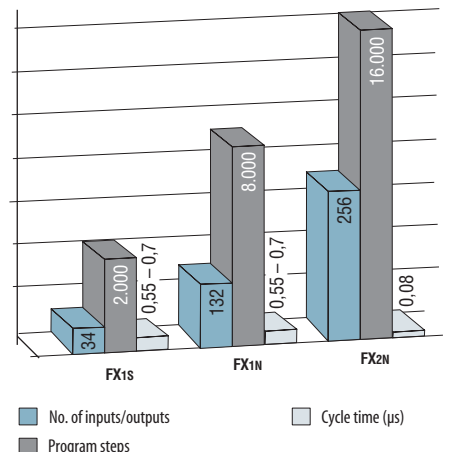

Features

The modular design of the FX1N/FX2N series makes it extremely flexible, enabling it to be used for a very broad range of applications.

You can configure tailor-made systems by combining modules from a variety of different categories (see figure).

All modules are electrically isolated from their environment with optocouplers for maximum reliability.

Communications modules

Interface modules with RS232/RS422/RS485 interfaces for the connection of peripherals and PLC-PLC links. Network modules for Profibus/DP, ASI and for the configuration of proprietary Mitsubishi networks

Positioning modules

High-speed counter modules with support for the connection of incremental rotary transducers and positioning modules for servo and stepping motor drives

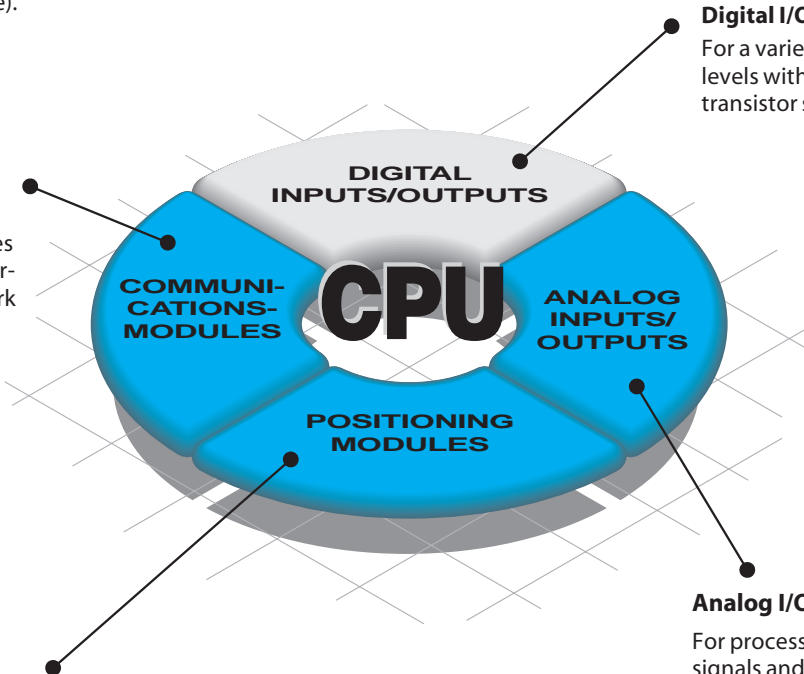

Digital I/O modules

For a variety of signal levels with relay or transistor switches

Analog I/O modules

For processing current/voltage signals and temperature registration with a direct connection option for PT100 resistance thermometers and thermocouples

Digital and special function modules – configuration

The options for using digital and special function modules are dictated by the CPU used in the system.

When calculating the number of special function modules you can use in a system you must take both the number of digital modules and the maximum number of special function modules that can be used into account.

The table on the right provides a simplified guide to the number of modules you can use in each system type. More detailed information and the basic principles of system configuration can be found on page 21 ff.

CPU type	System restrictions
FX1S	Stand-alone PLC with 10 / 14 / 20 or 30 I/Os; no special function modules but 1 I/O adapter board can be installed
FX1N	PLC with max. 132 I/Os; max. 2 special function modules supported
FX2N	PLC with max. 256 I/Os; max. 8 special function modules



Handling

Installation

Handling and installation of the modules are very simple.

All modules are fitted with an integrated DIN adapter for snap-on installation on DIN rail systems.

If you wish, the modules can also be installed normally on flat surfaces with screw fastenings.

In the FX1N and FX2N series all connections between the CPU's system bus and the expansion and special function modules are made with the standard flat ribbon cable. No other internal system wiring is required for connecting the CPU and modules.

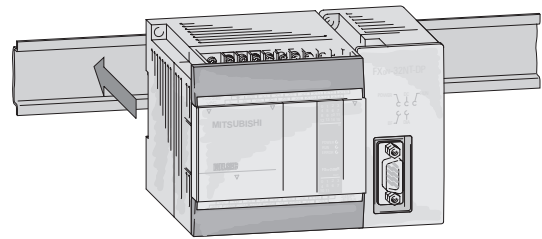
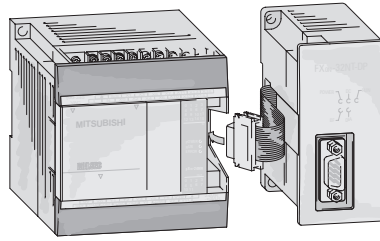

Wiring

All external wiring is connected to the standard cable terminals to the screw terminals on the modules. The entire terminal block has a cover which provides protection against short circuits and inadvertent contact.

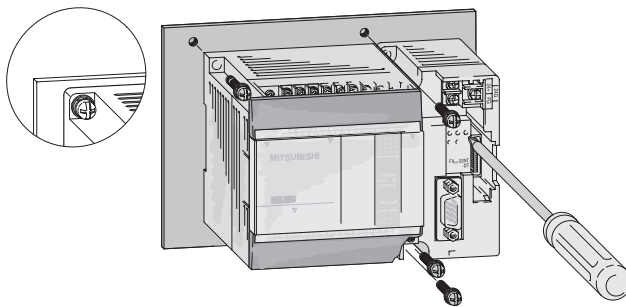

Programming

All CPUs have a standardised programming interface for the connection of a programming unit or a personal computer.

Simple control tasks can be programmed directly in ladder or instruction list using hand-held programming units, the control units of the MAC E series and GOT series or the programming tool FX-PCS/WIN and GX Developer (FX). In addition to this the CPUs can also be programmed with the GX IEC Developer (FX) software package, which runs on a normal PC. This powerful programming environment can be used to create large application programs conforming to the IEC 1131.3 (EN 61131) standard.

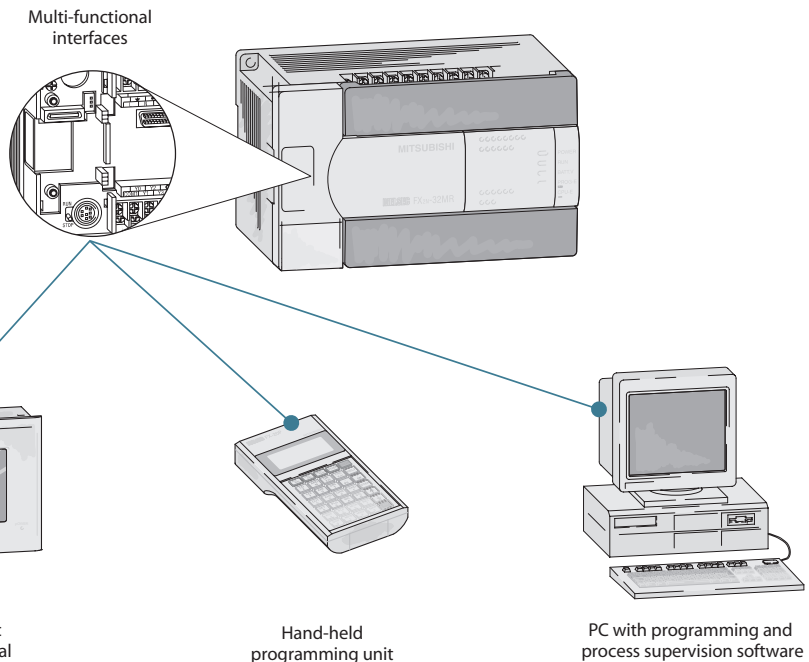

BASICS



Process visualisation

For more effective supervision of machines and processes you can configure a process visualisation system as a hardware or software solution with partial or full graphical support. Process visualisation products available from Mitsubishi include a variety of different operator terminals and the powerful MX SCADA process visualisation software package.

Peripherals

Separate interface modules enable the connection of output devices such as printers and also a variety of input devices such as barcode readers. Optional plug-in interfaces support the connection of additional programming or operator terminals, as well as the realization of various serial links. A range of special communications modules is also available for the integration of your PLC systems in a variety of networks.

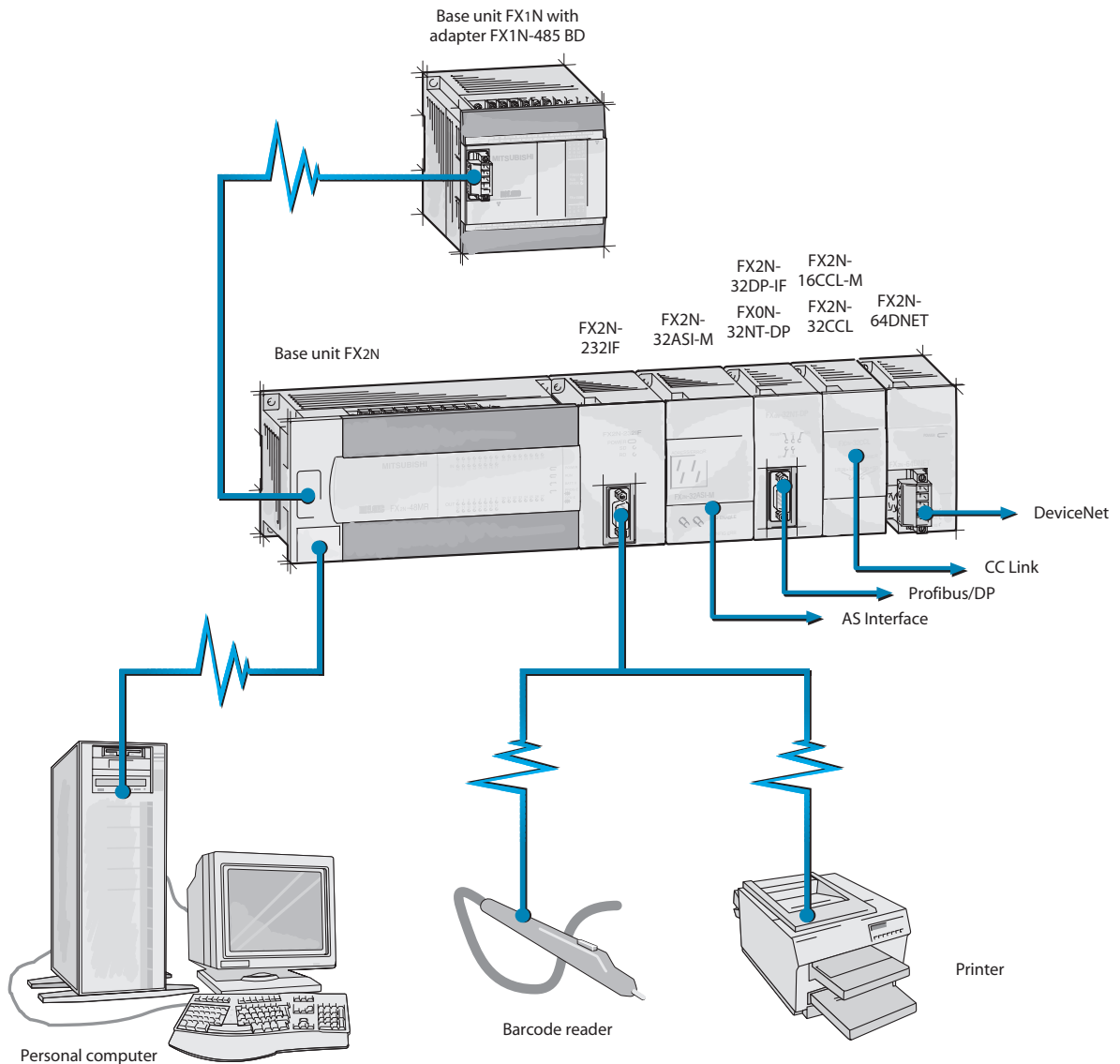
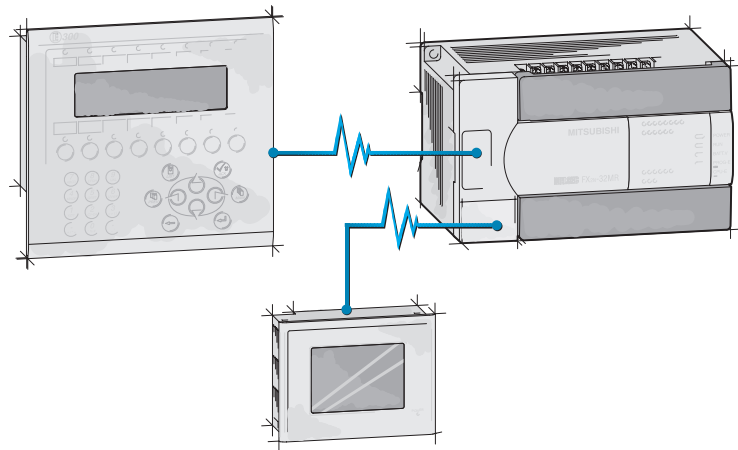

BASICS



MELSEC Networks

BASICS

TCP/IP ETHERNET

Ready for immediate operation with the worldwide standard TCP/IP protocol. A PC connected to the Ethernet has full access to all PLCs in the MELSECNET, all the way down to the I/Os on the production level.

MELSECNET/10 and -NET(II)

Low-cost cabling, brilliantly simple set-up and maximum availability thanks to redundancy and Floating Master. The max. coverage is up to 30 km.

MELSECNET/B

A cost-effective alternative within the production level. Enables implementation of easily-manageable configurations for complex applications by means of distributed intelligence.

CC-Link

The network for the control and I/O level comprises capabilities like real-time processing and distributed intelligence. Modules of third-party manufacturers can be integrated in this open network.

MELSEC I/O-LINK

Remote module distribution to the machine. Devices of third-party manufacturers can be integrated. Cabling with twisted pair cable in a tree structure.

MELSEC FX-PPN

The FX-PPN construction enables a network for up to 8 FX controllers as clients. The maximum coverage is up to 500 m. A standard twisted-pair cable can be used as the communications media.

COMMAND LEVEL

TCP/IP ETHERNET

CONTROL LEVEL

MELSECNET/10
MELSECNET(II)
MELSECNET/B
CC-Link

PRODUCTION LEVEL

CC-Link
MELSEC I/O LINK
MELSEC FX-PPN

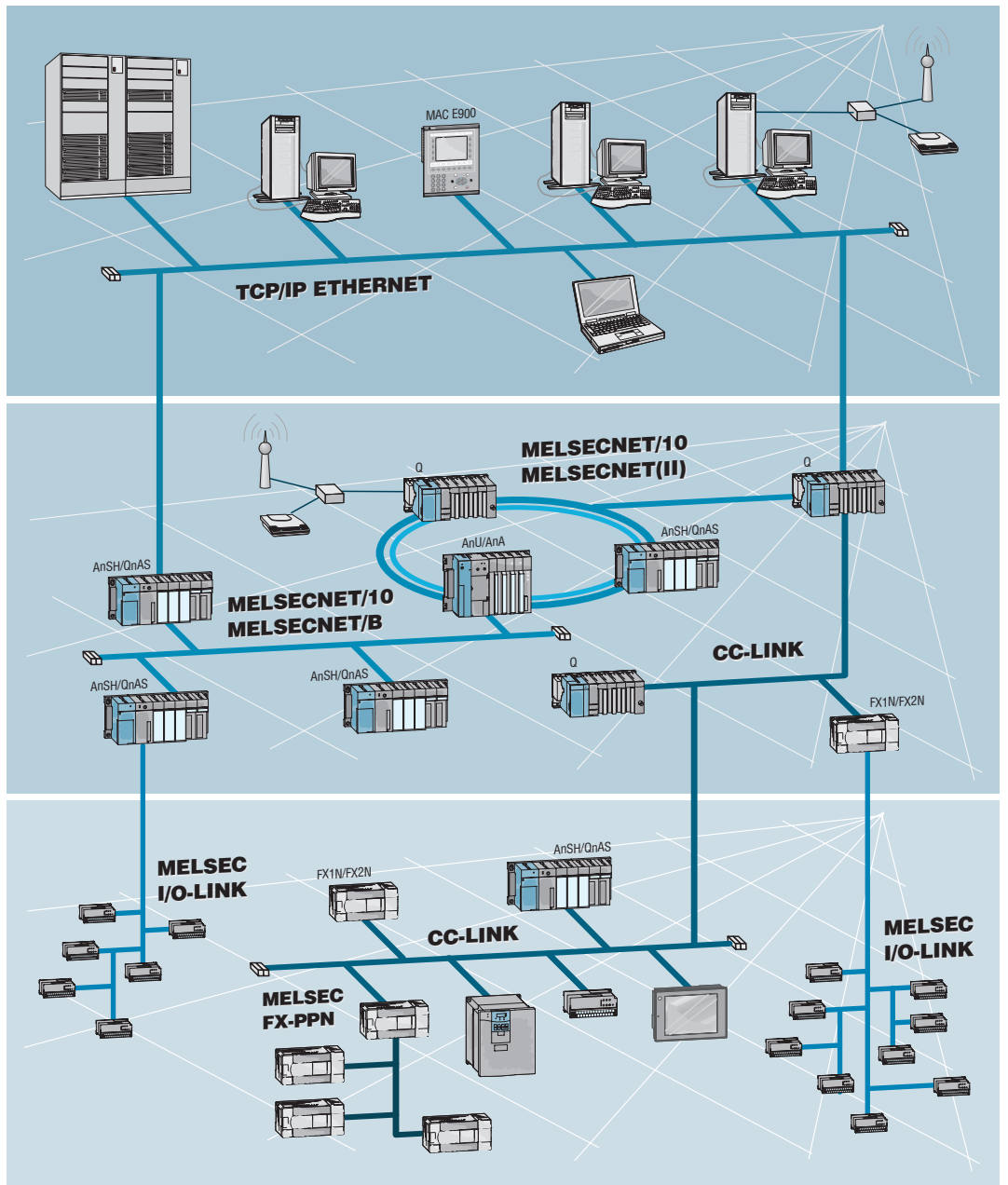

Open Networks

MAP 3.0 ETHERNET

Interdepartmental data exchange between the command and production levels using a non-proprietary protocol with short throughput times.

CC-Link

The new open network for the control and I/O level. Different sensors and actuators can be connected independently from the manufacturer. Up to 64 participants can be linked up to a network.

Profibus/DP

Enables quick and simple connection of sensors and actuators from different manufacturers to MELSEC PLCs, with data transfer rates of up to 12 Mbaud.

DeviceNet

Cost-effective CAN-based network communications. Fault-resistant network structure where components of different manufacturers can be integrated quickly and easily.

AS-Interface

International standard for the lowest field bus level. Connection of conventional sensors and actuators with twisted pair cable.

CANopen

Cost-effective communications network in interference tolerant network structure. Components of different manufacturers can be integrated easily and quickly.

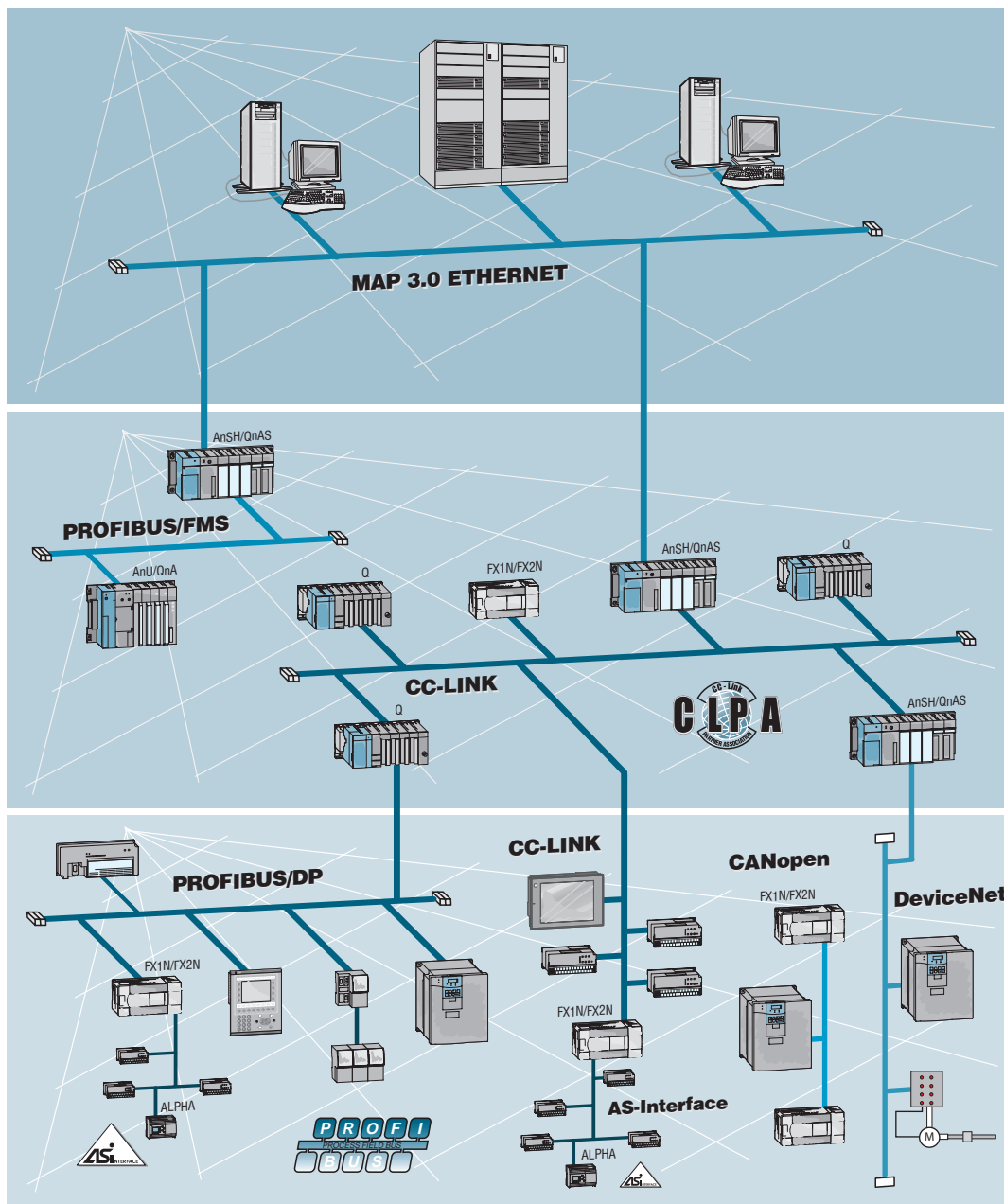

COMMAND LEVEL
MAP 3.0 ETHERNET

CONTROL LEVEL
Profibus/FMS
CC-Link

PRODUCTION LEVEL
Profibus/DP
DeviceNet
AS-Interface
CC-Link
CANopen

BASICS



The MELSEC FX1S Series

BASICS

Description

The MELSEC FX1S is the cost-effective entry to the MELSEC family. It was developed following user-oriented criteria and provides

- very compact package
- amazing functionality
- a significant decrease of costs

Existing FX0S/FX0N applications are terminal- and program-compatible with the new FX1S/FX1N this way making the adjustment easier.

To meet the increased demands the FX1S compared to its predecessor FX0S is extended by additional functions such as

- Incorporated positioning control
- High-speed operations
- Increased counting frequencies on the counting inputs
- Ample memory capacity and devices
- Additional setup and display functions
- Enhanced communication functions

System Structure

- Base unit with full PLC functionality
- Integrated power supply unit
- CPU
- Maintenance-free EEPROM memory
- Integrated digital inputs and outputs
- Real-time clock
- User-friendly programming systems, including IEC 1131.3 (EN 61131)-compatible programming software, HMIs and hand-held programming units
- Accessories

Equipment Features

Base units are available in a number of versions with different power supply and output type configurations.

You can choose between units with 100 – 230 V AC or 24 V DC power supplies and relay or transistor outputs.

All the base unit versions have the same basic CPU and performance specifications. Thanks to the extended communicational functions the FX1S can be integrated easily into a peer-to-peer or a 1:n network.



High-speed inputs for fast counting tasks with counting frequencies of up to 60 kHz and **interrupt processing capabilities**

The **internal service power supply unit** for 24 V DC has a capacity of 200 mA.

All units feature two **analog potentiometers** for setpoint value entry and an **integrated RUN/STOP** switch.

Square pulse output

Two **integrated high speed pulse outputs** for frequencies up to 100 kHz for outputting **pulse signals** and controlling stepping motors

Integration of **interface, extension, and functions adapters** for direct installation in the base unit

Your PLC programs are stored in a maintenance-free **EEPROM user memory** with a capacity of 2,000 program steps, so there is no need for a backup battery to protect against power failures.

Integrated serial RS422 interface for direct communication with computers

Flexible installation with the integrated DIN rail adapter and screw fastening hose for mounting on flat surfaces

Password access protection facility for effective protection of your intellectual property.

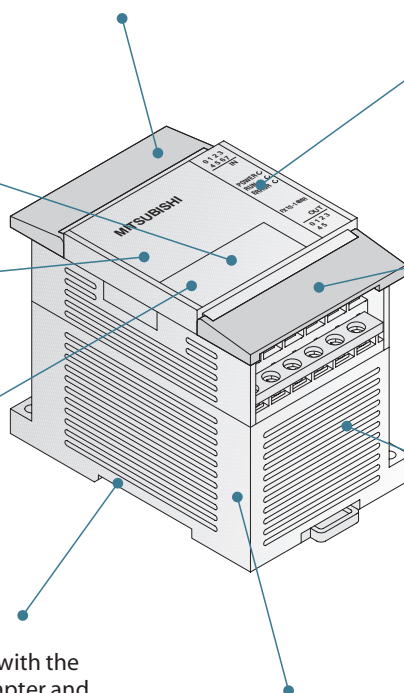

Description of the Unit

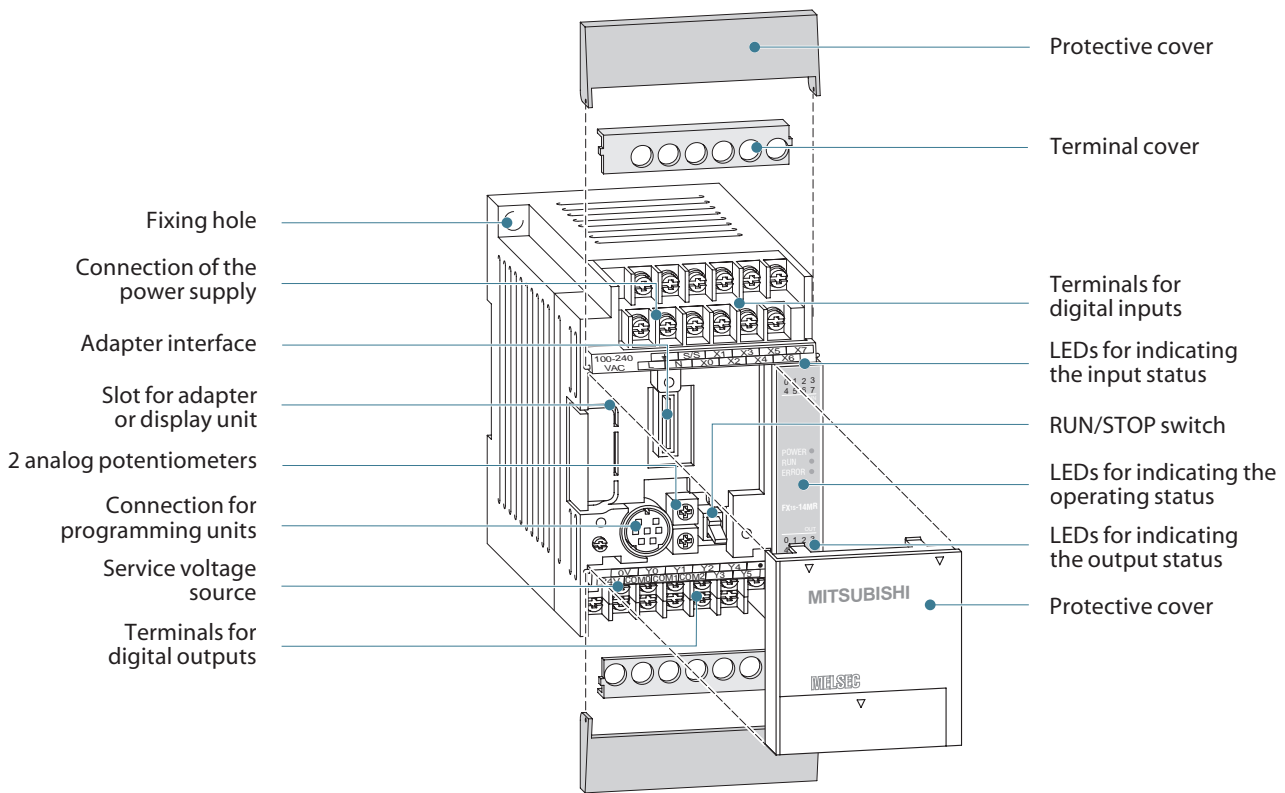

Reference Table for Model Designation Code

FX□□		-	14	M	R	E	S	UL
1			2	3	4	5a	5b	6

The code in detail:

- FX□□** = PLC series
- 1** Designation of the PLC series
- 2** Number of inputs/outputs e.g. 14 I/Os
- 3** Description of the unit type:
 - M = base unit
 - E = extension unit
 - EX = modular input extension
 - EY = modular output extension
- 4** Description of the output type:
 - R = relay
 - T = transistor
- 5a** Power supply:
 - E = 100/240 V AC
 - D = 24 V DC
 - UA1 = Power source and inputs as AC type
- 5b** Model variants:
 - S = Inputs selectable as sink or source type
 - Relay outputs
 - SS = Inputs selectable as sink or source type
 - Transistor outputs
 - source type
- 6** UL = UL certification

General Specifications

General Specifications	Data
Ambient temperature	0 – 55 °C
Operating temperature	0 – 55 °C
Storage temperature	-20 – +70 °C
Primary power supply	24 V DC, 400 mA; ripple ratio at maximum load: ≤ ±5 %
Protection	IP 20
Noise durability	1000 Vpp with noise generator; 1 μs at 30 – 100 Hz
Dielectric withstand voltage	1500 V AC, 1 min. (500 V AC for direct voltage modules)
Ambient relative humidity	35 – 85 % (non-condensing)
Shock resistance	Acc. to IEC 68-2-27 (15 G (3 times each in 3 directions for 11 ms))
Vibration resistance	Acc. to IEC 68-2-6 (1 G: resistance to vibrations from 57 – 150 Hz for 80 minutes along all 3 axes; 0.5 G for DIN rail mounting)
Insulation resistance	500 V DC, 5 MΩ
Ground	Class 3
Fuse	3 A
Environment	Avoid environments containing corrosive gases, install in a dust-free location.
Certifications	UL / CSA / CE / LR / (approx. summer 2002: DNV / RINA / BV / GL / ABS)

Specifications of Base Units

Specifications	FX1S-10 MR-DS	FX1S-10 MR-ES/UL	FX1S-10 MT-DSS	FX1S-10 MT-ESS/UL	FX1S-14 MR-DS	FX1S-14 MR-ES/UL	FX1S-14 MT-DSS	FX1S-14 MT-ESS/UL		
Electrical data										
Max. number inputs/outputs	10	10	10	10	14	14	14	14		
Power supply	AC range (+10%, -15%)	—	100–240 V AC	—	100–240 V AC	—	100–240 V AC	—	100–240 V AC	
	Frequency at AC	Hz	—	50/60 (±10 %)	—	50/60 (±10 %)	—	50/60 (±10 %)	—	50/60 (±10 %)
	DC range (+10%, -15%)	24 V DC	—	24 V DC	—	24 V DC	—	24 V DC	—	
Max. input apparent power	W	6	19	6	19	6.5	19	6.5	19	
Inrush current at ON	100 V AC	—	15 A / 5 ms	—	15 A / 5 ms	—	15 A / 5 ms	—	15 A / 5 ms	
	200 V AC	—	25 A / 5 ms	—	25 A / 5 ms	—	25 A / 5 ms	—	25 A / 5 ms	
	24 V DC	15 A / 0.1 ms	—	15 A / 0.1 ms	—	15 A / 0.1 ms	—	15 A / 0.1 ms	—	
Allowable momentary power failure time	ms	5	10	5	10	5	10	5	10	
External current supply (24 V DC)	mA	—	400	—	400	—	400	—	400	
Inputs										
Integrated inputs	6	6	6	6	8	8	8	8		
Min. current for logical 1 X0→X7 / X10→∞	mA	4.5 / 3.5	4.5 / 3.5	4.5 / 3.5	4.5 / 3.5	4.5 / 3.5	4.5 / 3.5	4.5 / 3.5		
Max. current for logical 0	mA	1.5	1.5	1.5	1.5	1.5	1.5	1.5		
Response time	ms	For all units of the MELSEC FX1S series values: 10 ms (at time of shipping), adjustable from 0 to 15 ms in steps of 1 ms.								
Outputs										
Integrated outputs	4	4	4	4	6	6	6	6		
Output	Type	Relay	Relay	Transistor	Transistor	Relay	Relay	Transistor	Transistor	
Switching voltage (max.)	V	Generally for relay version: < 250 V AC, < 30 V DC; for transistor version: 5 – 30 V DC								
Max. output current	- per output	A	2	2	0.5	0.5	2	2	0.5	0.5
	- per group*	A	8	8	0.8	0.8	8	8	0.8	0.8
Max. switching current	- inductive load	W	80 VA	80 VA	12 W	12 W	80 VA	80 VA	12 W	12 W
	- lamp load	W	100	100	0.9	0.9	100	100	0.9	0.9
Response time	ms	10	10	0.2	0.2	10	10	0.2	0.2	
Life of contacts (switching times)		For all base units of the MELSEC FX1S series values: 3000000 at 20 VA; 1000000 at 35 VA; 200000 at 80 VA								
Mechanical data										
Weight	kg	0.22	0.3	0.22	0.3	0.22	0.3	0.22	0.3	
Dimensions (W x H x D)	mm	60 x 90 x 49	60 x 90 x 75	60 x 90 x 49	60 x 90 x 75	60 x 90 x 49	60 x 90 x 75	60 x 90 x 49	60 x 90 x 75	
Order information	Art. no.	141240	141243	141246	139435	141247	141248	141249	139436	

* The limitation applies only per reference terminal for each group, 4 and 8 outputs for relays and 2 and 4 outputs for transistors. Please observe the terminal assignments for the group identification.

Programming Specifications

System Specifications

Program data

Program memory	2,000 steps EEPROM (internal)
Program execution	Periodical execution of the stored program
Program protection	Password protection with 3 protection levels
Number of instructions	29 sequence instructions, 2 step ladder instructions, 89 applied instructions
Cycle period	0.55 – 0.7 μs / log. instruction

Operands

Internal relays	512 total, with 384 general (M0 – M383) and 128 buffered (M384 – M511)
Special relays	256 (M8000 – M8255)
Step relays	128
Timers	63 (max. 63 timers, partially switchable to 100 ms, 10 ms and 1 ms)
External setpoint entry via potentiometer	2 potentiometers
Counter	32 (16 bit), C0 – C31
High-speed counter inputs	1 phase: 6 input for max. 60 kHz, 2 phases: 2 inputs for max. 30 kHz
Data register	256 subtotal (128 common (D0 – D127) and 128 buffered (D128 – D255))
Index register	16
Special register	256 (16 bit), D8000 – D8255
Pointer	64, P0 – P63
Nesting operands	8, N0 – N7
Interrupt inputs	6
Constants	16 bits: K: -32768 to +32767, hex: 0–FFFF 32 bits: K: 2147483648 to +2147483647, hex: 0–FFFF FFFF

Specifications of Base Units

FX1S-20 MR-DS	FX1S-20 MR-ES/UL	FX1S-20 MT-DSS	FX1S-20 MT-ESS/UL	FX1S-30 MR-DS	FX1S-30 MR-ES/UL	FX1S-30 MT-DSS	FX1S-30 MT-ESS/UL
20	20	20	20	30	30	30	30
—	100–240 V AC	—	100–240 V AC	—	100–240 V AC	—	100–240 V AC
—	50/60 (±10 %)	—	50/60 (±10 %)	—	50/60 (±10 %)	—	50/60 (±10 %)
24 V DC	—	24 V DC	—	24 V DC	—	24 V DC	—
7	20	7	20	8	21	8	21
—	15 A / 5 ms	—	15 A / 5 ms	—	15 A / 5 ms	—	15 A / 5 ms
—	25 A / 5 ms	—	25 A / 5 ms	—	25 A / 5 ms	—	25 A / 5 ms
15 A / 0.1 ms	—	15 A / 0.1 ms	—	15 A / 0.1 ms	—	15 A / 0.1 ms	—
5	10	5	10	5	10	5	10
—	400	—	400	—	400	—	400
12	12	12	—	16	16	16	16
4.5 / 3.5	4.5 / 3.5	4.5 / 3.5	—	4.5 / 3.5	4.5 / 3.5	4.5 / 3.5	4.5 / 3.5
1.5	1.5	1.5	—	1.5	1.5	1.5	1.5
For all units of the MELSEC FX1S series values: 10 ms (at time of shipping), adjustable from 0 to 15 ms in steps of 1 ms.							
8	8	8	8	14	14	14	14
Relay	Relay	Transistor	Transistor	Relay	Relay	Transistor	Transistor
Generally for relay version: < 250 V AC, < 30 V DC; for transistor version: 5 – 30 V DC							
2	2	0.5	0.5	2	2	0.5	0.5
8	8	0.8	0.8	8	8	0.8	0.8
80 VA	80 VA	12 W	12 W	80 VA	80 VA	12 W	12 W
100	100	0.9	0.9	100	100	0.9	0.9
10	10	0.2	0.2	10	10	0.2	0.2
For all base units of the MELSEC FX1S series values: 3,000,000 at 20 VA; 1,000,000 at 35 VA; 200,000 at 80 VA							
0.3	0.4	0.3	0.4	0.35	0.45	0.35	0.45
75 x 90 x 49	75 x 90 x 75	75 x 90 x 49	75 x 90 x 75	100 x 90 x 49	100 x 90 x 75	100 x 90 x 49	100 x 90 x 75
141251	141252	141254	139437	141255	141256	141257	139439



BASICS



Interface, Extension and Functions Adapter FX1N-□□□-BD

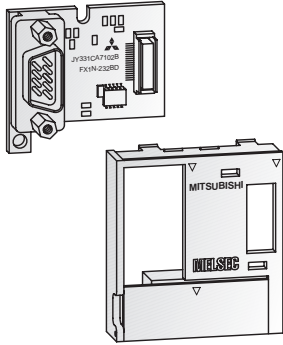

For the FX1S PLC several different interface, extension, and functions adapters are available for the direct installation in the controller.

For detailed information please refer to the chapter "Special functions modules" for the FX1N/FX2N series (see table below).

Adapter	FX1N-4EX-BD	FX1N-2EYT-BD	FX1N-2AD-BD	FX1N-1DA-BD
Function	4 digital inputs	2 transistor outputs	AD converter	DA converter
Catalogue reference	Page 36	Page 36	Page 37	Page 38
Order information	Art. no. 139418	139420	139421	139422

Adapter	FX1N-8AV-BD	FX1N-422-BD	FX1N-232-BD	FX1N-485-BD	FX1N-CNV-BD
Function	Analog setting values	Communications interface	Communication interface	Communication interface	Adapter for special function modules*
Catalogue reference	Page 37	Page 46	Page 46	Page 60	Page 62
Order information	Art. no. 130744	130741	130743	130742	130745

* For connection to FX0N-232ADP and FX0N-485ADP (refer to page 46 and 60)

Display Module FX1N-5DM

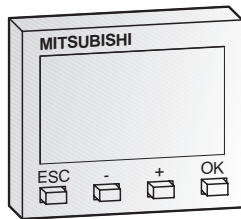

The display module FX1N-5DM is inserted directly into the controller and enables monitoring and editing of the data stored in the PLC.

The display module e.g. can be used instead of digital switches and external 7-segment displays in very confined areas. The following detailed functions can be performed by the FX1N-5DM:

- Bit and word device monitoring (X, Y, M and T, C, D)
- Current and set values can be altered during monitoring (T, C and D)
- Devices can be forced on and off (Y, M and S)
- Current time of the real-time clock can be displayed and set

Specifications	FX1N-5DM	
Environmental specifications	Conforms to FX1S base units	
Power supply	5 V DC ±5 % (from base unit)	
Current consumption	mA	110
Display	LCD (backlight)	
Weight	kg	0.02
Dimensions (W x H x D)	mm	40 x 32 x 11
Order information	Art. no.	129197



Control and Display Panels

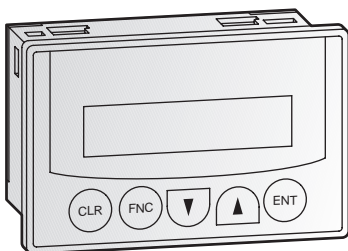

Besides the control and display panel FX-10-DM-E for the monitoring and setting of process data in the PLC (see also page 64) several other control and display panels for FX1S are available. A detailed overview of these is included in the HMI technical catalogue.



Memory Cassette FX1N-EEPROM-8L for FX1S/FX1N

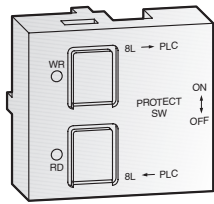

The FX1N-EEPROM-8L memory cassette provides an internal EEPROM memory with a capacity of 2,000 steps PLC program for the FX1S.

Moreover, the program can be transferred with this memory cassette from the memory of one FX1S or FX1N controller to another without any programming unit.

Specifications	FX1N-EEPROM-8L	
Environmental specifications	Conforms to FX1S base units	
Power supply	5 V DC \pm 5% (from base unit)	
Dimensions (W x H x D)	mm	33 x 30 x 9
Order information	Art. no.	130746

Simulation Strip: Input-SIM for FX1S/FX1N

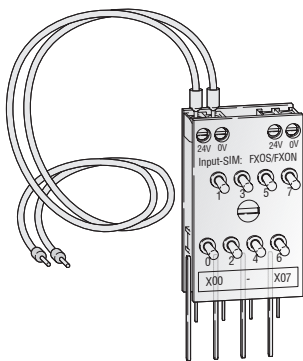

The simulation strip has 8 switches for simulating digital inputs. The strip is directly mounted to the terminals of the unit and fixed with screws to the terminal block. A cable is provided for connecting the strip to the power supply.

The simulation strip is applicable for all PLCs of the MELSEC FX1S and FX1N series. The simulation strip can be expanded with another strip for further inputs.

Specifications	Input-SIM: FX1S/FX1N	
Switches	8	
Dimensions (W x H x D)	mm	30 x 50 x 15
Order information	Art. no.	65081

Simulation Box

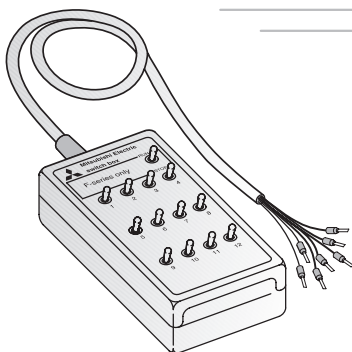

The simulation box has 12 switches for simulating digital inputs. It can be used on all controllers of the MELSEC FX family.

Specifications	Simulation Box	
Switches	12	
Dimensions (W x H x D)	mm	50 x 100 x 25
Order information	Art. no.	3386

FX1S Messenger

The FX1S Messenger Set is an alarm and remote control system for wireless telephony (GSM). In case of a fault up to 4 messages can be transmitted from the FX1S PLC via SMS to up to 4 different mobile phones. The mobile phone can immediately be used to undertake a fault repair action to the system.

With the help of the easy-to-use FX1S Messenger parameter-setting software you enter the required parameters such as mobile phone numbers and alarm messages offline on your PC or notebook. For operation a SIM card (3 V) is merely necessary.

Specifications	FX1S Messenger	
Delivery schedule	PLC FX1S-10MR-DS, GSM modem TC35, mobile phone aerial, FX1S Messenger software, interface adapter FX1N-232-BD, connection cable	
Order information	Art. no.	141697

Terminal Assignment of Base Units

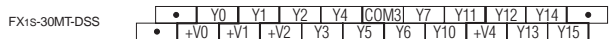
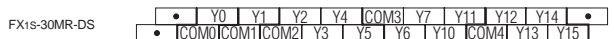
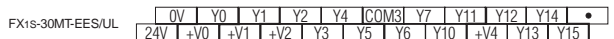
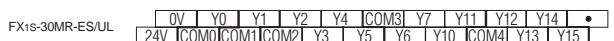
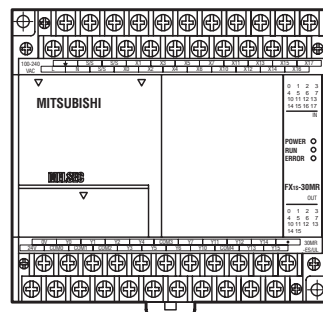
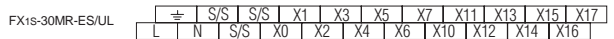
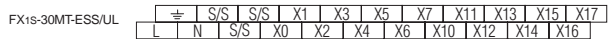
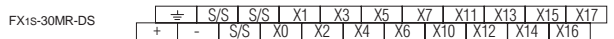
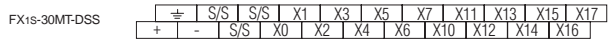
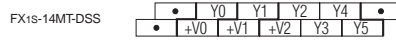
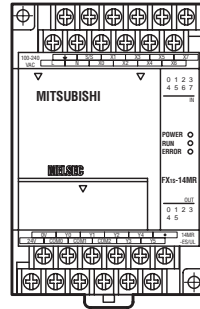
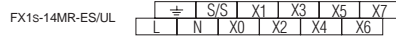
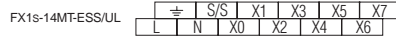
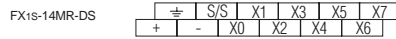
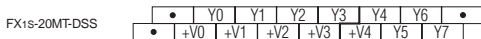
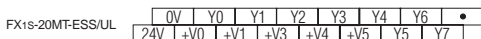
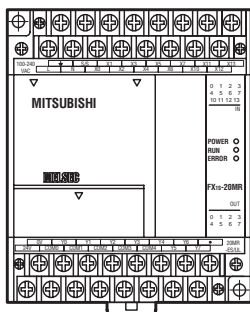
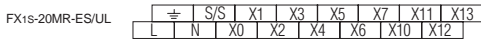
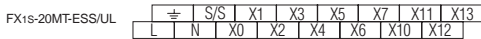
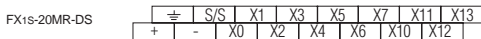
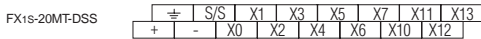
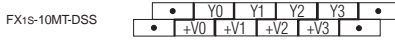
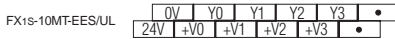
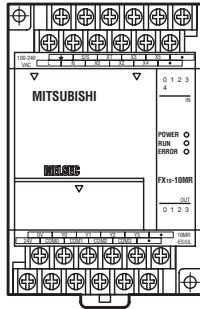
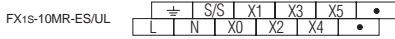
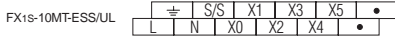
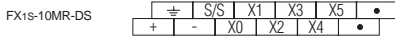
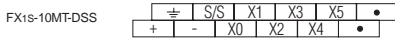

BASICS



Dimensions of Base Units

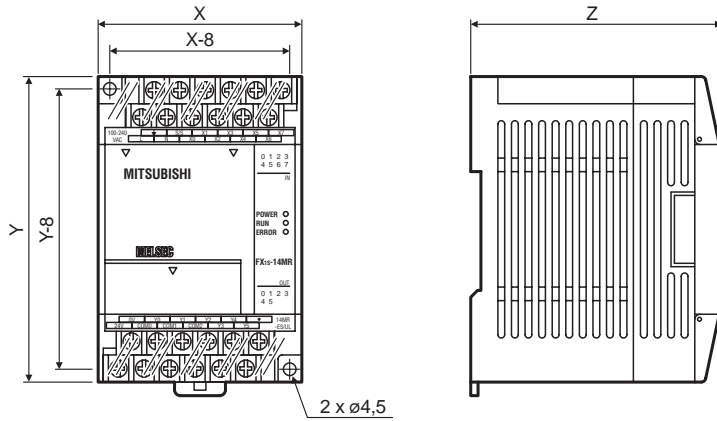

Base unit	X	Y	Z
FX1S-10MR-DS	60	90	49
FX1S-10MR-ES/UL	60	90	75
FX1S-10MT-DSS	60	90	49
FX1S-10MT-ESS/UL	60	90	75
FX1S-14MR-DS	60	90	49
FX1S-14MR-ES/UL	60	90	75
FX1S-14MT-DSS	60	90	49
FX1S-14MT-ESS/UL	60	90	75
FX1S-20MR-DS	75	90	49
FX1S-20MR-ES/UL	75	90	75
FX1S-20MT-DSS	75	90	49
FX1S-20MT-ESS/UL	75	90	75
FX1S-30MR-DS	100	90	49
FX1S-30MR-ES/UL	100	90	75
FX1S-30MT-DSS	100	90	49
FX1S-30MT-ESS/UL	100	90	75

BASICS



The MELSEC FX1N Series

Description

Small-scale PLC offering excellent value for money.

- Small
- Fast
- Universal
- Modular expansion capability

The ability to combine the compact base units with small, modular expansion units and compact I/O expansion units makes the FX1N enormously flexible, giving you a highly economical combination of the cost benefits of compact systems with the versatile expansion capabilities of modular systems.

The FX1N series base units can be combined with all FX0N or FX2N extension units without any problems.

System Structure

- Base unit with full PLC functionality
- Integrated power supply unit
- CPU
- Maintenance-free EEPROM memory
- Integrated digital inputs and outputs
- Expansion units for adapting the controller system to the required I/O ranges and functionality
- Configurable as a slave station in peer-to-peer and 1:n networks
- Configurable with special function modules in various open networks
- User-friendly programming systems, including IEC 1131.3-compatible programming software, HMIs and hand-held programming units
- Wide range of accessories

Equipment Features

Base units are available in a number of versions with different power supply and output type configurations.

You can choose between units with 100–230VAC or 12–24VDC power supplies and relay or transistor outputs.

All the base unit versions have the same basic CPU and performance specifications.

As a special feature functional and interface adapters as well as a display module can be installed directly into the controller.

In comparison to the predecessor module the following features of the FX1N were further improved:

- Improved performance and functionality
- Faster processing speeds
- Enlarged counting frequency at the counter inputs
- Enhanced programming capacity
- Enhanced communications functions
- Ample device range

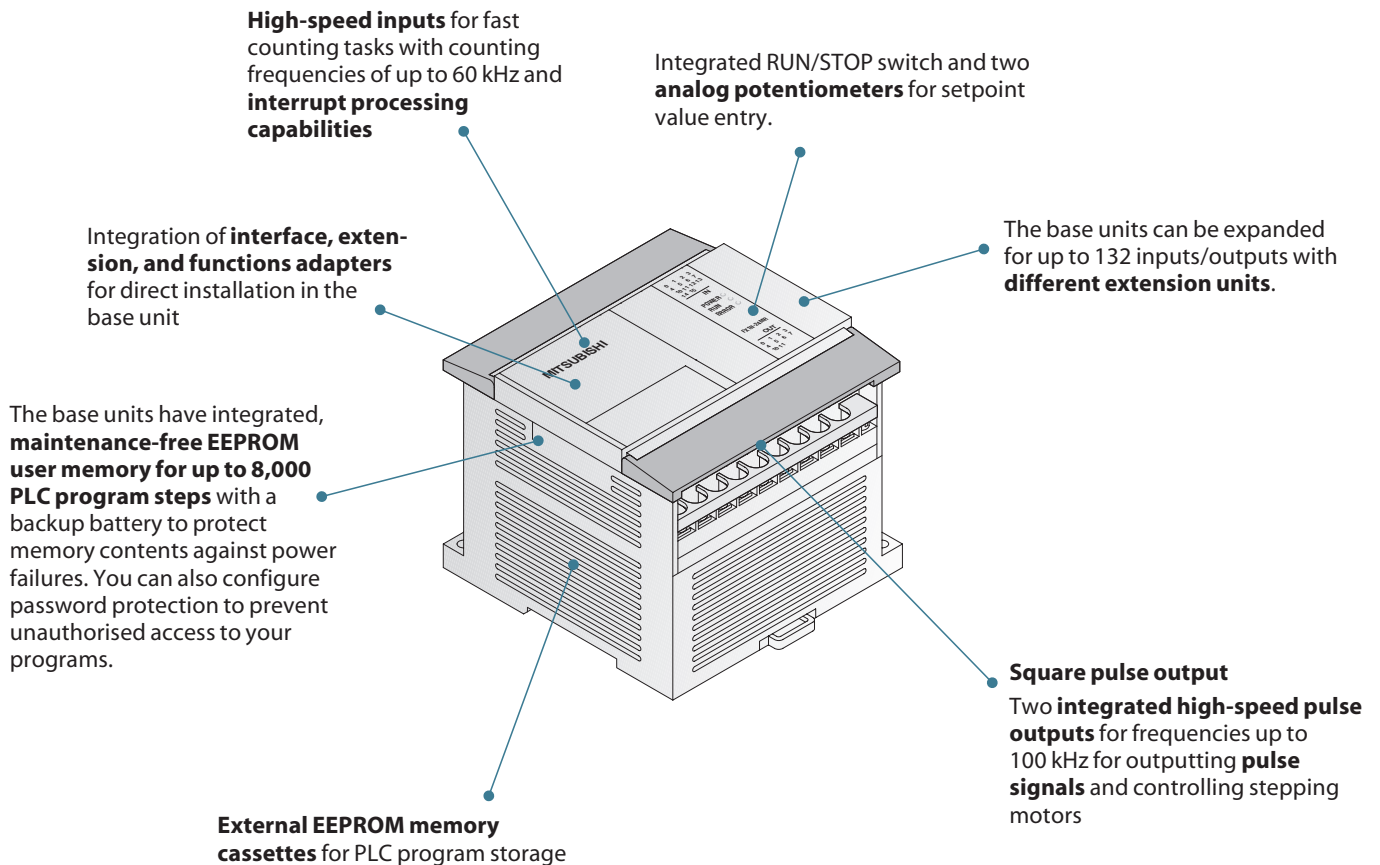

The MELSEC FX2N Series

Description

The MELSEC FX2N series has the most powerful CPUs in the MELSEC FX family. It combines the advantages of a compact PLC with the performance boost of modular PLC systems:

- One of the fastest PLC systems available, with a program cycle period of just 0.08 µs per logical instruction
- Powerful basic instruction set with additional 125 dedicated instructions for fast, efficient programming of complex tasks
- Simple handling
- Integrated real-time clock
- Integrated PID controller with auto-tuning facility
- Floating-point math, square root function
- Big memory capacity for up to 16,000 PLC program steps

System Structure

- Base unit with full PLC functionality
- Integrated power supply unit
- CPU
- Integrated digital inputs and outputs
- Supplementary add-in function boards for adapting the controller system to the required I/O ranges and functionality
- Integration as a master or slave station in peer-to-peer networks and as a slave station in 1:n networks
- Master function for a distributed I/O Link network or Actor-Sensor Interface (ASI)
- including IEC 1131.3-compatible programming software, HMI and hand-held programming units
- Wide range of accessories

Equipment Features

A basic MELSEC FX2N PLC system consists of a stand-alone base unit. Just like the modules in the other FX series these base units contain all the PLC components, including the CPU, memory and the I/O control circuitry.

All the base unit versions in the series have the same basic CPU and performance specifications.

A total of 21 different base units are available, with between 16 and 128 I/Os in their standard configuration. Versions are available with 100 – 230 V AC and 24 V DC power supplies and relay or transistor outputs. The digital inputs are powered by the integrated power supply unit. Removable terminal blocks make reconfiguration for new tasks very quick and easy.

A range of powerful expansion and special function modules enable you to configure your setup flexibly to provide the precise functionality and I/O specifications required by your application.

You can add I/Os to the base units by installing modular expansion units with 8 or 16 additional I/Os each. You can also add a range of compact expansion units and special function modules – for example for processing analog signals, for positioning tasks and to provide additional interfaces.

Integrated high-speed counter inputs for processing fast input signals. For example, you can configure two 60 kHz counters or four 10 kHz counters.

Interrupt processing is also handled via the inputs.

Add-in function boards can be installed in the PLC to provide a **second RS485 / RS422 / RS232 communications interface** for programming or network configurations.

An add-in function board with 8 analog potentiometers is also available.

Integrated serial interface for direct communication with computers

An **integrated RUN/STOP** switch is available.

RAM/EEPROM memory for up to **16,000 PLC program steps** gives you plenty of reserve, even for big, complex applications.

The base units can be expanded to provide configurations with up to 256 inputs and outputs with **modular and compact expansion units**.

Integrated real-time clock with year, month and time

Two **integrated pulse outputs** for frequencies from 2 to 20,000 Hz **with deceleration and acceleration ramps** for controlling stepping motors and outputting **pulse-width modulated signals**

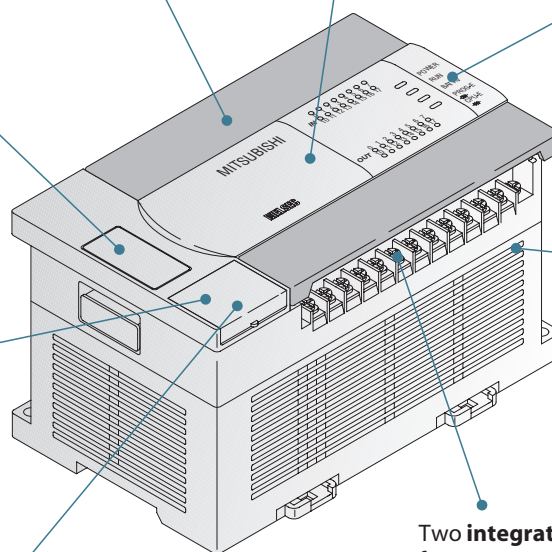

Description of Units

■ FX1N Series

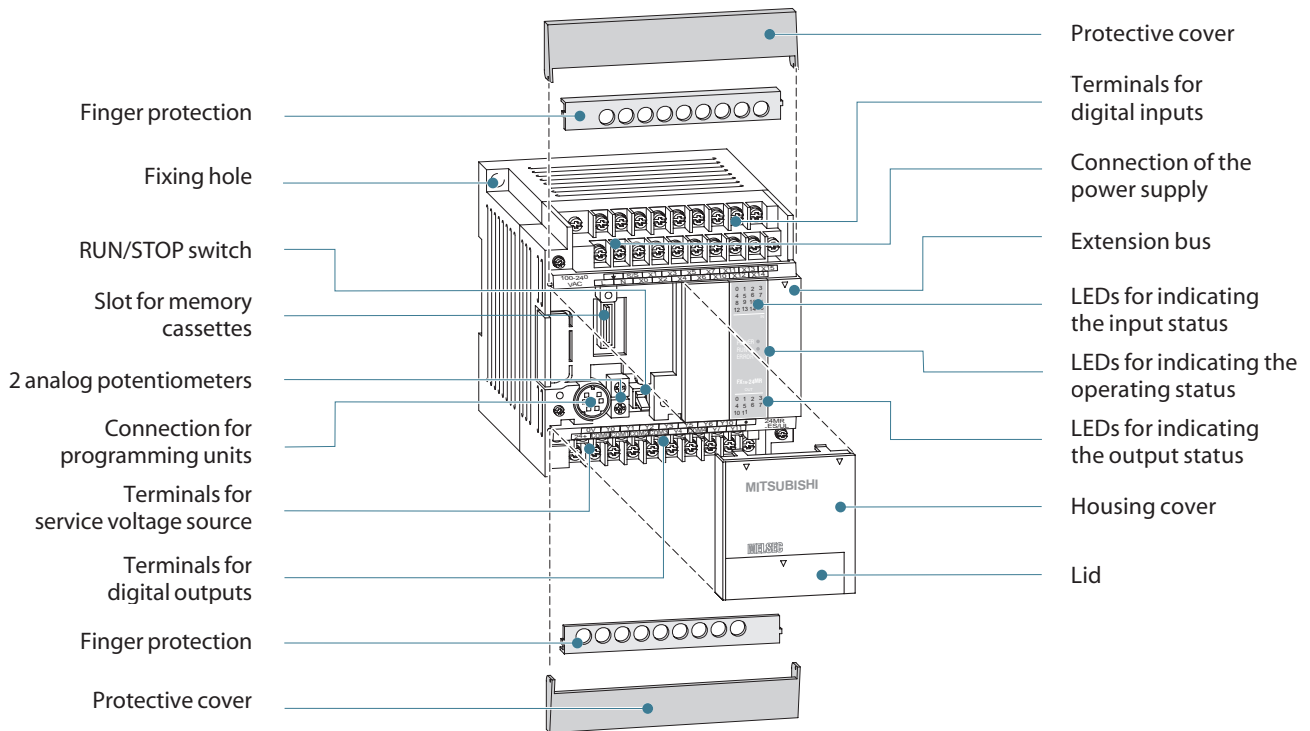

■ FX2N Series

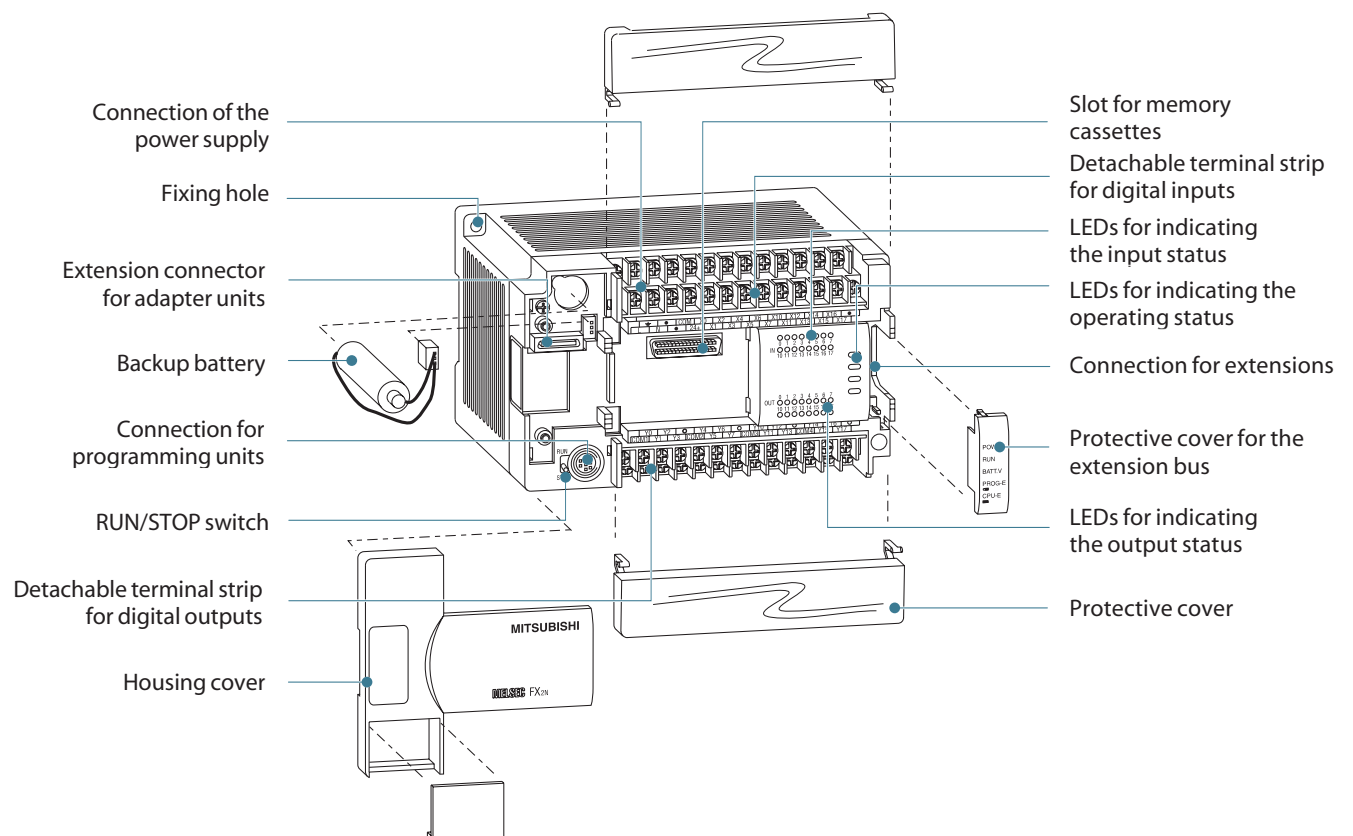

Combining Units from Different Series

The I/O expansion modules and special function modules from the two series can be combined at will, subject to the restrictions imposed by the differences between the systems.

For example, you can use all the modules for the FX0N or FX2N series in combination with a base unit from the FX2N series. Combined use of modules from both series is also possible.

A special conversion adapter is available for connecting modules from the old FX series to the base units of the FX1N/FX2N series (designation: FX1N-CNV-IF for FX1N and FX2N-CNV-IF for FX2N).

The tables and figures below show the restrictions and other special requirements that apply for combined use of modules from different systems.

Series	FX1N	FX2N
Restrictions	The FX0N/FX2N special function modules are useable without restrictions. Up to 2 modules are connectable.	The FX0N/FX2N special function modules are useable without restrictions. Up to 8 modules are connectable.
Special requirements	Modules FX0N-485ADP and FX0N-232ADP are connected to the left of the CPU and require function board FX1N-CNV-BD for connection to the FX1N.	Modules FX0N-485ADP and FX0N-232ADP are connected to the left of the CPU and require function board FX2N-CNV-BD for connection to the FX2N.

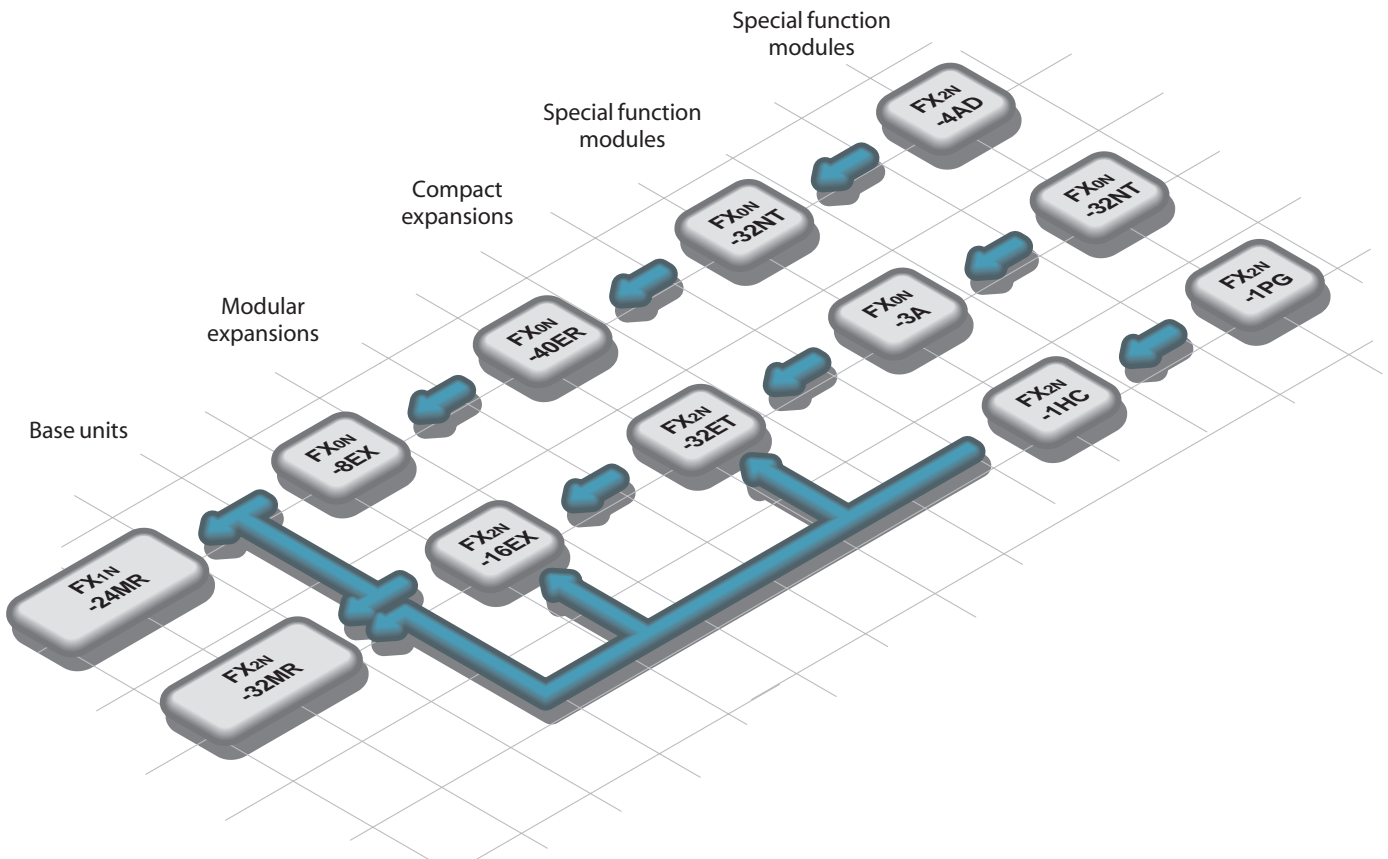

Special Function Modules MELSEC FX1N/FX2N

☑ FX1N ☑ FX2N

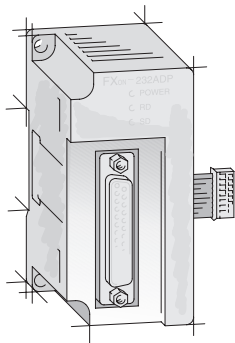

Left-side installation

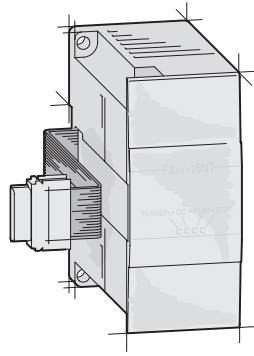

Right-side installation

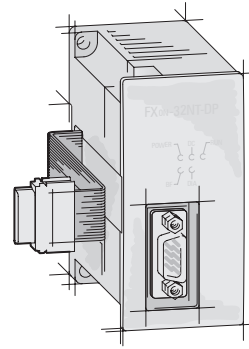

Right-side installation

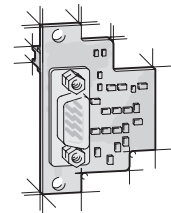

Installation in base unit

General

Additional special function modules are available that make it possible to extend the capacity of the basic and extension units of your PLC system.

There are three basic categories of special function modules:

- Modules that occupy digital I/Os (connected on the right hand side of the base unit). These are the digital compact and modular extension units as well as the special function modules.
- Modules of the FX0N series that do not occupy any digital I/Os (connected on the left hand side of the base unit). These are the FX0N-232ADP and the FX0N-485ADP.
- Internal adapter boards for the FX1S/FX1N series and the FX2N series. These expansion units are installed directly in the base unit and do not occupy any digital I/Os.

FX1N series configuration notes

The configuration specifications for the FX1N series permit connection of the following combinations of expansion units to the base units:

- a maximum of 2 special function modules or
- digital expansion modules with up to 32 inputs and outputs (4 x 8 I/Os or 2 x 16 I/Os) or
- one special function module and one digital expansion module with up to 16 inputs and outputs (2 x 8 I/Os or 1 x 16 I/Os)

The same configuration specifications apply for the connection of compact expansion modules (limited to 128 I/Os). Provided you observe these rules the system's power supply will also be adequate to provide the 5 V DC input required by the FX0N-232ADP communications module.

Similarly, the power supply for HMIs such as the MAC E series operator terminals or the programming tools is provided via the system's 5 V bus.

FX2N series configuration notes

The configuration specifications for the FX2N series permit connection of the following combinations of units:

- A maximum of 8 special function modules or
- Digital expansion modules with up to 256 I/Os

Please note that it is important to calculate the connected load to ensure that the internal 5 V bus has adequate capacity for the installed modules.

When using special function modules you must also check the 24 V power supply load – the necessary 24 V power can be drawn from the internal service power supply, but it may be necessary to complement this with an external power supply in some configurations.

You can calculate the precise power load with the values provided in the table on the next page.

Calculation of the Power Consumption

FX1N FX2N

The power consumption figures on the 5 V DC bus for the special function modules are shown in the specifications tables on the following pages.

The maximum permissible currents on the 5 V DC bus are shown in the table below.

Module	Max. current on 5 V bus
FX2N-□□M□-ES(ESS)	290 mA
FX2N-□□E□-ES(ESS)	690 mA

The residual currents for the 24 V DC service voltage at different input/output configurations are shown in the tables on the right.

Special function modules have to be supplied externally, if the residual current for the service voltage is not satisfying.

A maximum of 256 I/Os is possible.

Max. residual current values (in mA) for FX2N-16M□-E□□ through FX2N-32M□-E□□, FX2N-32E□-E□□ for the permissible configuration

Number of additional outputs	24	25					
	16	100	50	0			
	8	175	125	75	25		
	0	250	200	150	100	50	
		0	8	16	24	32	
Number of additional inputs							

Max. residual current values (in mA) for FX2N-48M□-E□□ through FX2N-128M□-E□□, FX2N-48E□-E□□ for the permissible configuration

Number of additional outputs	48	10								
	40	85	35							
	32	160	110	60	10					
	24	235	185	135	85	35				
	16	310	260	210	160	110	60	10		
	8	385	335	285	235	185	135	85	35	
	0	460	410	360	310	260	210	160	110	60
			0	8	16	24	32	40	48	56
Number of additional inputs										

Sample Calculations

FX1N FX2N

The tables below and on the right show different examples for sample power calculation for a PLC system.

The current values for the special function modules can be found in the specifications on the following pages.

Comparison with the current value tables show that the calculated figures for the 5 V bus lie within the allowable ranges.

In the example below all units can be supplied sufficiently with the internal 24 V power supply.

Module	No.	24 V DC calculation		5 V DC calculation	
		Current / module	Calculation	Current / module	Total current
FX2N-80MR-ES	1	460 mA	+460 mA	+290 mA	+290 mA
FX2N-4AD	3	50 mA	-150 mA	30 mA	-90 mA
FX2N-4DA	2	200 mA	-400 mA	30 mA	-60 mA
FX2N-232IF	1	80 mA	-80 mA	40 mA	-40 mA
			-170 mA !!!		290 - 190 mA
				Result:	100 mA (OK!)

An external 24 V power supply has to be added in the example above.

Module	No.	Number of I/Os			24 V DC calculation		5 V DC calculation		
		X	Y	X/Y	Total ^①	Total current ^②	Current / module	Total current	
FX2N-48MR-ES/UL	1	24	24	—	X = 8 Y = 24 →	+185 mA	290 mA	+290 mA	
FX2N-16EYR-ES/UL	1	—	16	—			—	0 mA	
FX2N-8EX-ES/UL	1	8	—	—			—	0 mA	
FX2N-8EYR-ES/UL	1	—	8	—			—	0 mA	
FXON-3A	1	—	—	8			-90 mA	30 mA	-30 mA
						+95 mA (OK!)		+260 mA (OK!)	
FX2N-32ER-ES/UL	1	16	16	—	X = 16 Y = 0 →	+150 mA	690 mA	+690 mA	
FX2N-16EX-ES/UL	1	16	—	—			—	0 mA	
FX2N-4AD	1	—	—	8			50 mA	30 mA	-30 mA
FX2N-1HC	1	—	—	8			0 mA	90 mA	-90 mA
Result:		64 + 64 + 24 = 152! (< 256) OK!				+100 mA (OK!)		+570 mA (OK!)	

① Total no. of I/Os which are connected to a base unit to calculate the max. residual current values (see tables) ② see tables above (max. residual current values)

Configuration Example FX1N

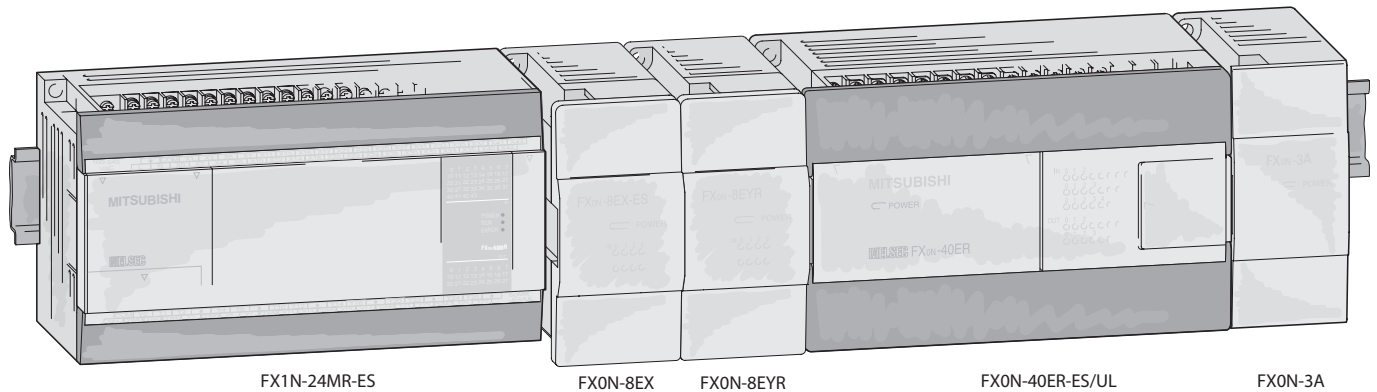

The addressing of the special function modules is independent of the addressing of the digital inputs/outputs. An example of addressing is shown in the table on the right.

Configuration	FX1N-24MR-ES/UL	FX0N-8EX-ES/UL	FX0N-8EYR-ES/UL	FX0N-40ER-ES/UL	FX0N-3A	Total
Number						
Inputs X	14	8	—	24	—	46
Outputs Y	10	—	8	16	—	34
Special function modules	—	—	—	—	8	8
Addresses						
Inputs X	0 – 15	20 – 27	—	30 – 57	—	
Outputs Y	0 – 11	—	20 – 27	30 – 47	—	
Special function modules					Nr. 0	
						88

Configuration Example FX2N

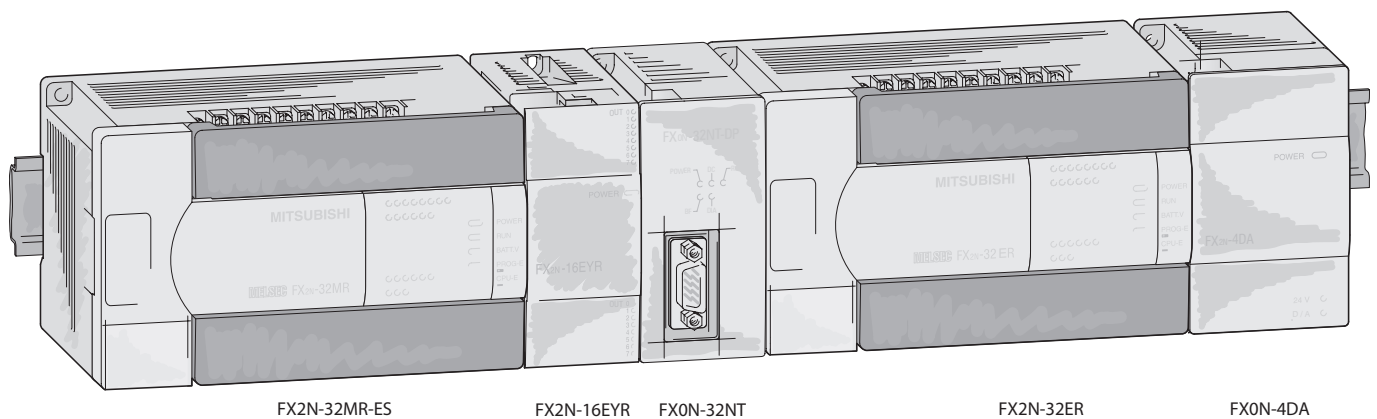

The addressing of the special function modules is independent of the addressing of the digital inputs/outputs. An example of addressing is shown in the table on the right.

Configuration	FX2N-32MR-ES/UL	FX2N-16EYR-ES/UL	FX0N-32NT/DP	FX2N-32ER-ES/UL	FX0N-4DA	Total
Number						
Inputs X	16	—	—	16	—	32
Outputs Y	16	16	—	16	—	48
Special function modules	—	—	8	—	8	16
Addresses						
Inputs X	0 – 17	—	—	20 – 37	—	
Outputs Y	0 – 17	20 – 37	—	40 – 57	—	
Special function modules			Nr. 0		Nr. 1	
						96

Environmental Specifications

☑ FX1N ☑ FX2N

General specifications	Data
Ambient temperature	0 – 55 °C
Operating temperature	0 – 55 °C
Storage temperature	-20 – +70 °C
Service power supply	24 V DC, 400 mA (FX1N); 250/460 mA (FX2N) ripple ratio at maximum load: ≤ ±5 %
Protection	IP 20
Noise durability	1000 Vpp with noise generator; 1 ms at 30 – 100 Hz
Dielectric withstand voltage	1,500 V AC, 1 min.
Ambient relative humidity	35 – 85 % (non-condensing)
Shock resistance	FX1N: 15 G (3 times in 3 directions) for 11 ms; FX2N: 10 G (3 times in 3 directions)
Vibration resistance	FX1N: 1 G (resistance to vibrations from 57–150 Hz for 80 minutes along all 3 axes); 0.5 G for DIN rail mounting FX2N: 2 G (resistance to vibrations from 10 – 55 Hz for 2 hours along all 3 axes; 0.5 G for DIN rail mounting)
Insulation resistance	500 V DC, 5 MΩ
Ground	Class 3
Fuse	Up to FX1N-24□□: 1 A; from FX1N-40□□: 3 A; from FX2N-32□□: 3, 15 A; from FX2N-48□□: 5 A
Environment	Avoid environments containing corrosive gases, install in a dust-free location.
Certifications	FX1N: UL/CSA/CE/DNV/RINA/BV/GL/LR/ABS, FX2N: UL/CSA/CE/DNV/LR/GL/RINA

General Specifications

☑ FX1N ☑ FX2N

System specifications	FX1N	FX2N
Program data		
I/O points (addresses)	128 (+4 optional)	256
Address range	Max. 84 inputs X0–X123, max. 64 outputs Y0–Y77	Max. 248 inputs X0–X367, max. 248 outputs Y0–Y367
Program memory	8,000 steps EEPROM (internal), EEPROM/ EPROM cassettes (optional)	8,000 steps RAM (internal), 4,000 steps EPROM/EEPROM cassettes (optional), 16,000 steps RAM cassettes (optional), 16,000 steps EEPROM cassettes (optional) <small>for further details refer to p. 63</small>
Cycle period	0.55 – 1.0 μs /logical instruction	0.08 μs / logical instruction
Number of instructions	29 sequence instructions, 2 step ladder instructions, 89 applied instructions	27 sequence instructions, 2 step ladder instructions, 18 verify instructions, 107 applied instructions
Programming language	Step ladder, instruction list, SFC	Step ladder, instruction list, SFC
Program execution	Cyclical execution, refresh mode processing	Cyclical execution, refresh mode processing
Program protection	Password protection with 3 protection levels	Password protection with 3 protection levels
Operands		
Internal relays	1,536	3,072
Special relays	256	256
Step ladder	1,000	1,000
Timer	256	256
Ext. preset value via potentiometer	2	—
Counter	235	235
High-speed counter	6 single phase inputs (max. 60 kHz), 2 double phase inputs (max. 30 kHz)	6 single phase inputs (max. 60 kHz), 2 double phase inputs (max. 30 kHz)
Real-time clock	Year, month, day, hour, minut, second, weekday	Year, month, day, hour, minut, second, weekday
Data register	8,000	8,000
File register	Max. 7,000 (parameter editable), Total registers = 8,000	Max. 7,000 (parameter editable), Total registers = 8,000
Index register	16	16
Special register	256	256
Pointer	128	128
Nestings	8	8
Interrupt inputs	6	6
Constants	16 bits: K: -32768 to +32767, hex: 0–FFFF 32 bits: K: 2147483648 to +2147483647, hex: 0–FFFF FFFF	16 bits: K: -32768 to +32767, hex: 0–FFFF 32 bits: K: 2147483648 to +2147483647, hex: 0–FFFF FFFF 32 bits floating point: 0, ±1.175 x 10 ⁻³⁸ to ±3.403 x 10 ⁻³⁸

Base Units

FX1N FX2N

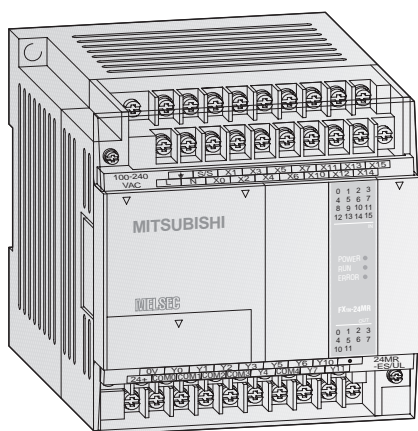

Base Units FX1N

The FX1N series base units are available with 14, 24, 40 or 60 input/output points.

It is possible to choose between relay and transistor output type.

Special Features:

- Integrated serial interface for communication between Personal computers and HMI
- Standard programming unit interface
- LEDs for indicating the input and output status
- Detachable terminal blocks at units with 40 and 60 I/Os
- Slot for memory cassettes
- All DC models with variable voltage from 12 up to 24 V
- Integrated real-time clock
- Exchangeable interface and I/O adapter boards for direct fitting into the base unit

Specifications	FX1N-14 MR-DS	FX1N-14 MR-ES/UL	FX1N-14 MT-DSS	FX1N-14 MT-ESS/UL	FX1N-24 MR-DS	FX1N-24 MR-ES/UL	FX1N-24 MT-DSS	FX1N-24 MT-ESS/UL		
Electrical data										
Integrated inputs/outputs	14	14	14	14	24	24	24	24		
Power supply	AC range (+10%, -15%)	—	100–240 V	—	100–240 V	—	100–240 V	—	100–240 V	
	Frequency at AC	Hz	—	50/60 (±10 %)	—	50/60 (±10 %)	—	50/60 (±10 %)	—	50/60 (±10 %)
	DC range (+20%, -15%)	12–24 V	—	12–24 V	—	12–24 V	—	12–24 V	—	
Max. input apparent power	W	13	29	13	29	15	30	15	30	
Inrush current at ON	100 V AC	—	15 A / 5 ms	—	15 A / 5 ms	—	15 A / 5 ms	—	15 A / 5 ms	
	200 V AC	—	25 A / 5 ms	—	25 A / 5 ms	—	25 A / 5 ms	—	25 A / 5 ms	
	24 V DC	25 A / 1 ms	—	25 A / 1 ms	—	25 A / 1 ms	—	25 A / 1 ms	—	
	12 V DC	22 A / 0.3 ms	—	22 A / 0.3 ms	—	22 A / 0.3 ms	—	22 A / 0.3 ms	—	
Allowable momentary power failure time	ms	5	10	5	10	5	10	5	10	
External service power supply (24 V DC)	mA	—	400	—	400	—	400	—	400	
Inputs										
Integrated inputs	8	8	8	8	14	14	14	14		
Min. current for logical 1 X0→X7 / X10→∞	mA	4.5 / 3.5	4.5 / 3.5	4.5 / 3.5	4.5 / 3.5	4.5 / 3.5	4.5 / 3.5	4.5 / 3.5		
Max. current for logical 0	mA	1.5	1.5	1.5	1.5	1.5	1.5	1.5		
Response time	For all base units of the MELSEC FX1N series: 10 ms (at time of shipment), partly adjustable between 0 and 15 ms									
Outputs										
Integrated outputs	6	6	6	6	10	10	10	10		
Output type	Relay	Relay	Transistor	Transistor	Relay	Relay	Transistor	Transistor		
Max. switching voltage	Generally for relay version: < 264 V AC, < 30 V DC; for transistor version: 5 – 30 V DC									
Max. output current	- per output	A	2	2	0.5	0.5	2	2	0.5	0.5
	- per group	A	8	8	0.8	0.8	8	8	0.8	0.8
Max. switching power	- inductive load	VA	80	80	12	12	80	80	12	12
	- lamp load	W	100	100	1.5	1.5	100	100	1.5	1.5
Response time	ms	10	10	< 0.2 (Y0, Y1 < 5 μs)	< 0.2 (Y0, Y1 < 5 μs)	10	10	< 0.2 (Y0, Y1 < 5 μs)	< 0.2 (Y0, Y1 < 5 μs)	
Life of contacts (switching times)	For all base units of the MELSEC FX1N series: 3,000,000 at 20 VA; 1,000,000 at 35 VA; 200,000 at 80 VA									
Mechanical data										
Weight	kg	0.45	0.45	0.45	0.45	0.45	0.45	0.45		
Dimensions (W x H x D)	mm	90 x 90 x 75	90 x 90 x 75	90 x 90 x 75	90 x 90 x 75	90 x 90 x 75	90 x 90 x 75	90 x 90 x 75		
Order information										
Art. no.	141254	141259	141260	139440	141261	141262	141263	139452		

Base Units

FX1N FX2N

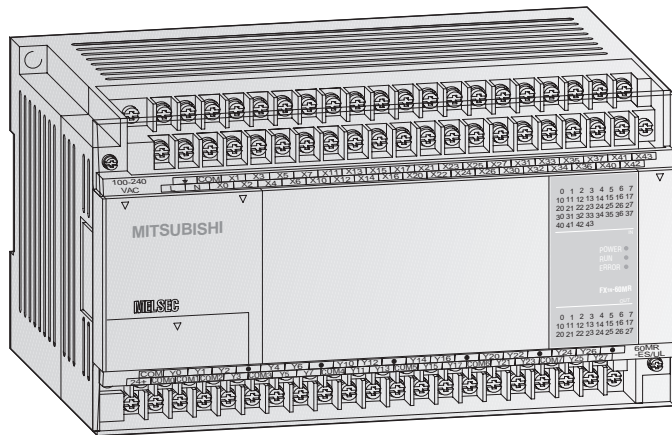

BASICS



Specifications	FX1N-40 MR-DS	FX1N-40 MR-ES/UL	FX1N-40 MT-DSS	FX1N-40 MT-ESS/UL	FX1N-60 MR-DS	FX1N-60 MR-ES/UL	FX1N-60 MT-DSS	FX1N-60 MT-ESS/UL		
Electrical data										
Integrated inputs/outputs	40	40	40	40	60	60	60	60		
Power supply	AC range (+10%, -15%)	—	100–240 V	—	100–240 V	—	100–240 V	—	100–240 V	
	Frequency at AC	Hz	—	50/60 (±10 %)	—	50/60 (±10 %)	—	50/60 (±10 %)	—	50/60 (±10 %)
	DC range (+20%, -15%)	—	12–24 V	—	12–24 V	—	12–24 V	—	12–24 V	
Max. input apparent power	W	18	32	18	32	20	35	20	35	
Inrush current at ON	100 V AC	—	15 A / 5 ms	—	15 A / 5 ms	—	15 A / 5 ms	—	15 A / 5 ms	
	200 V AC	—	25 A / 5 ms	—	25 A / 5 ms	—	25 A / 5 ms	—	25 A / 5 ms	
	24 V DC	—	25 A / 1 ms	—	25 A / 1 ms	—	25 A / 1 ms	—	25 A / 1 ms	
	12 V DC	—	22 A / 0.3 ms	—	22 A / 0.3 ms	—	22 A / 0.3 ms	—	22 A / 0.3 ms	
Allowable momentary power failure time	s	5	10	5	10	5	10	5	10	
External service power supply (24 V DC)	mA	—	400	—	400	—	400	—	400	
Inputs										
Integrated inputs	24	24	24	24	36	36	36	36		
Min. current for logical 1 X0→X7 / X10→∞	mA	3.5 / 4.5	3.5 / 4.5	3.5 / 4.5	3.5 / 4.5	3.5 / 4.5	3.5 / 4.5	3.5 / 4.5		
Max. current for logical 0	mA	1.5	1.5	1.5	1.5	1.5	1.5	1.5		
Response time	For all base units of the MELSEC FX1N series: 10 ms (at time of shipment), partly adjustable between 0 and 15 ms									
Outputs										
Integrated outputs	16	16	16	16	24	24	24	24		
Output type	Relay	Relay	Transistor	Transistor	Relay	Relay	Transistor	Transistor		
Max. switching voltage	Generally for relay version: < 264 V AC, < 30 V DC; for transistor version: 5 – 30 V DC									
Max. output current	- per output	A	2	2	0.5	0.5	2	2	0.5	0.5
	- per group	A	8	8	0.8	0.8	8	8	0.8	0.8
Max. switching power	- inductive load	VA	80	80	12	12	80	80	12	12
	- lamp load	W	100	100	1.5	1.5	100	100	1.5	1.5
Response time	ms	10	10	< 0.2 (Y0, Y1 < 5 μs)	< 0.2 (Y0, Y1 < 5 μs)	10	10	< 0.2 (Y0, Y1 < 5 μs)	< 0.2 (Y0, Y1 < 5 μs)	
Life of contacts (switching times)	For all base units of the MELSEC FX1N series: 3,000,000 at 20 VA; 1,000,000 at 35 VA; 200,000 at 80 VA									
Mechanical data										
Weight	kg	0.65	0.65	0.65	0.65	0.8	0.8	0.8	0.8	
Dimensions (W x H x D)	mm	130 x 90 x 75	130 x 90 x 75	130 x 90 x 75	130 x 90 x 75	175 x 90 x 75	175 x 90 x 75	175 x 90 x 75	175 x 90 x 75	
Order information										
Art. no.	141264	141265	141266	139454	141267	141268	141269	139455		

Base Units

FX1N FX2N

BASICS

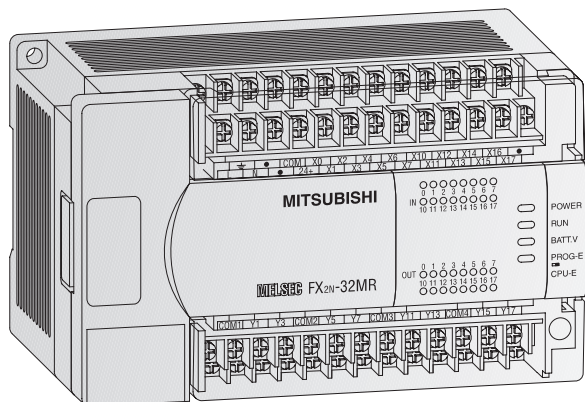

Base Units FX2N

The FX2N series base units are available with 16, 32, 48, 64, 80 or 128 input/output points. It is possible to choose between relay and transistor output type.

Special Features:

- Exchangeable interface modules for direct mounting into a base unit
- Standard programming unit interface
- LEDs for indicating the input and output status
- Detachable terminal blocks
- Slot for memory cassettes for up to 16 k steps PLC program
- Integrated real-time clock

Specifications	FX2N-16 MR-DS	FX2N-16 MR-ES/UL	FX2N-16 MT-ESS/UL	FX2N-32 MR-DS	FX2N-32 MR-ES/UL	FX2N-32 MT-DSS	FX2N-32 MT-ESS/UL
Electrical data							
Integrated inputs/outputs	16	16	16	32	32	32	32
Power supply	AC range (+10%,-15%)	—	100–240 V	—	100–240 V	—	100–240 V
	Frequency at AC	Hz	50/60 (±10 %)	50/60 (±10 %)	—	50/60 (±10 %)	50/60 (±10 %)
	DC range (+20 %, -30 %)	24 V	—	—	24 V	—	24 V
Max. input apparent power	25 W	30 VA	30 VA	25 W	40 VA	25 W	40 VA
Inrush current at ON	AC 100 V	—	40 A < 5 ms	—	40 A < 5 ms	—	40 A < 5 ms
	AC 200 V	—	60 A < 5 ms	—	60 A < 5 ms	—	60 A < 5 ms
Allowable momentary power failure time	ms	5	10	5	10	5	10
External service power supply (24 V DC)	mA	—	250	—	250	—	250
Power supply int. bus (5 V DC)	mA	290	290	290	290	290	290
Inputs							
Integrated inputs	8	8	8	16	16	16	16
Input current X0→X7 / X10→∞	mA	7/5	7/5	7/5	7/5	7/5	7/5
Min. current for logical 1 X0→X7 / X10→∞	mA	4.5 / 3.5	4.5 / 3.5	4.5 / 3.5	4.5 / 3.5	4.5 / 3.5	4.5 / 3.5
Max. current for logical 0	mA	1.5	1.5	1.5	1.5	1.5	1.5
Isolation	Photocoupler isolation between input terminals and PC power for all base units.						
Response time	For all base units of the MELSEC FX2N series: 10 ms (at time of shipment), partly adjustable between 0 and 15 ms (REF, FNC51 = 0 – 60 ms)						
Outputs							
Integrated outputs	8	8	8	16	16	16	16
Output type	Relay	Relay	Transistor	Relay	Relay	Transistor	Transistor
ON voltage (max.)	Generally for relay version: < 250 V AC, < 30 V DC; for transistor version: 5 – 30 V DC						
Max. output current	- per output	A	2	0.5 / 0.3 ^①	2	0.5 / 0.3 ^①	0.5 / 0.3 ^①
	- per group*	A	8	0.8 / 1.6 ^②	8	0.8 / 1.6 ^②	0.8 / 1.6 ^②
Max. switching power	- inductive load	W	80	12	80	12	12
	- lamp load	W	100	1.5	100	1.5	1.5
Response time	ms	10	10	< 0.2	10	< 0.2	< 0.2
Life of contacts (switching times)	For all base units of the MELSEC FX2N series: 3,000,000 at 20 VA; 1,000,000 at 35 VA; 200,000 at 80 VA						
Mechanical data							
Weight	kg	0.6	0.6	0.6	0.65	0.65	0.65
Dimensions (W x H x D)	mm	130 x 90 x 87	130 x 90 x 87	130 x 90 x 87	150 x 90 x 87	150 x 90 x 87	150 x 90 x 87
Order information							
Art. no.	141270	141271	141272	141273	141274	141275	141276

^① for Y0 and Y1 = 0.3 A; all others 0.5 A ^② 0.8 for 4 per group and 1.6 for 8 per group

* This limitation applies only per reference terminal for each group, 4 and 8 outputs for relays and 2 and 4 outputs for transistors. Please observe the terminal assignments for the group identification.

Base Units

FX1N FX2N

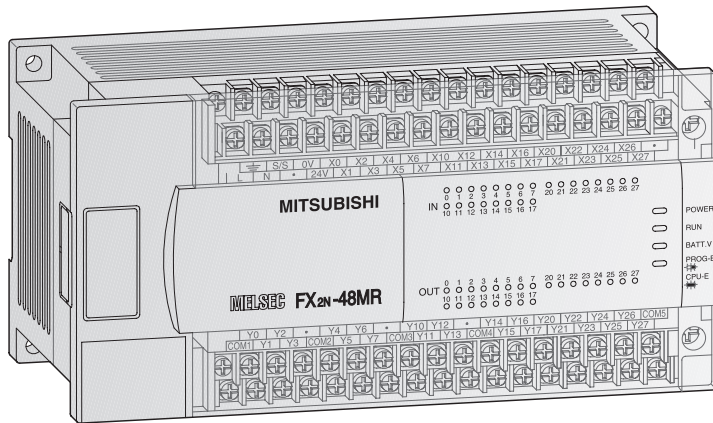

BASICS



1



1



FX2N-48 MR-DS	FX2N-48 MR-ES/UL	FX2N-48 MT-ESS/UL	FX2N-48 MT-DSS	FX2N-64 MR-DS	FX2N-64 MR-ES/UL	FX2N-64 MT-DSS	FX2N-64 MT-ESS/UL
48	48	48	48	64	64	64	64
—	100–240 V	100–240 V	—	—	100–240 V	—	100–240 V
—	50/60 (±10 %)	50/60 (±10 %)	—	—	50/60 (±10 %)	—	50/60 (±10 %)
24 V	—	—	24 V	24 V	—	24 V	—
30 W	50 VA	50 VA	30 W	35 W	60 VA	35 W	60 VA
—	40 A < 5 ms	40 A < 5 ms	—	—	40 A < 5 ms	—	40 A < 5 ms
—	60 A < 5 ms	60 A < 5 ms	—	—	60 A < 5 ms	—	60 A < 5 ms
5	10	10	5	5	10	5	10
—	460	460	—	—	460	—	460
290	290	290	290	290	290	290	290
24	24	24	24	32	32	32	32
7/5	7/5	7/5	7/5	7/5	7/5	7/5	7/5
4.5 / 3.5	4.5 / 3.5	4.5 / 3.5	4.5 / 3.5	4.5 / 3.5	4.5 / 3.5	4.5 / 3.5	4.5 / 3.5
1.5	1.5	1.5	1.5	1.5	1.5	1.5	1.5
Photocoupler isolation between input terminals and PC power for all base units.							
For all base units of the MELSEC FX2N series: 10 ms (at time of shipment), partly adjustable between 0 and 15 ms (REFF, FNC51 = 0 – 60 ms)							
24	24	24	24	32	32	32	32
Relay	Relay	Transistor	Transistor	Relay	Relay	Transistor	Transistor
Generally for relay version: < 250 V AC, < 30 V DC; for transistor version: 5 – 30 V DC							
2	2	0.5 / 0.8 ^①	0.5 / 0.8 ^①	2	2	0.5 / 0.8 ^①	0.5 / 0.8 ^①
8	8	0.8 / 1.6 ^②	0.8 / 1.6 ^②	8	8	0.8 / 1.6 ^②	0.8 / 1.6 ^②
80	80	12	12	80	80	12	12
100	100	1.5	1.5	100	1.5	1.5	1.5
10	10	< 0.2	< 0.2	10	10	< 0.2	< 0.2
For all base units of the MELSEC FX2N series: 3,000,000 at 20 VA; 1,000,000 at 35 VA; 200,000 at 80 VA							
0.85	0.85	0.85	0.85	1.0	1.0	1.0	1.0
182 x 90 x 87	182 x 90 x 87	182 x 90 x 87	182 x 90 x 87	220 x 90 x 87	220 x 90 x 87	220 x 90 x 87	220 x 90 x 87
141277	141278	141280	141279	141281	141282	141283	141284

^① for Y0 and Y1 = 0.3 A; all others 0.5 A ^② 0.8 for 4 per group and 1.6 for 8 per group

* This limitation applies only per reference terminal for each group, 4 and 8 outputs for relays and 2 and 4 outputs for transistors. Please observe the terminal assignments for the group identification.

Base Units

FX1N FX2N

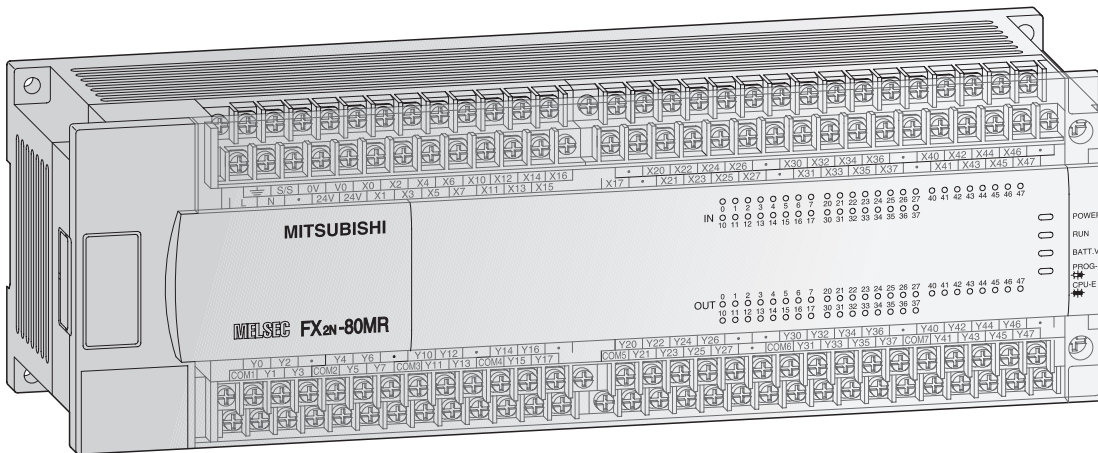

Specifications	FX2N-80 MR-DS	FX2N-80 MR-ES/UL	FX2N-80 MT-ESS/UL	FX2N-80 MT-DSS	FX2N-128 MR-ES/UL	FX2N-128 MT-ESS/UL
Electrical data						
Integrated inputs/outputs	80	80	80	80	128	128
Power supply	AC range (+10%,-15%)	—	100–240 V	100–240 V	—	100–240 V
	Frequency at AC	Hz	50/60 (±10 %)	50/60 (±10 %)	—	50/60 (±10 %)
	DC range (± 8 V)	24 V	—	—	24 V	—
Max. input apparent power	40 W	70 VA	70 VA	40 W	100 VA	100 VA
Inrush current at ON	100 V AC	—	40 A < 5 ms	40 A < 5 ms	—	50 A < 7 ms
	200 V AC	—	60 A < 5 ms	60 A < 5 ms	—	70 A < 7 ms
Allowable momentary power failure time	ms	5	10	5	10	10
External service power supply (24 V DC)	mA	—	460	460	—	460
Power supply int. bus (5 V DC)	mA	290	290	290	290	290
Inputs						
Integrated inputs	40	40	40	40	64	64
Input current X0→X7 / X10→∞	mA	7 / 5	7 / 5	7 / 5	7 / 5	7 / 5
Min. current for logical 1 X0→X7 / X10→∞	mA	4.5 / 3.5	4.5 / 3.5	4.5 / 3.5	4.5 / 3.5	4.5 / 3.5
Max. current for logical 0	mA	1.5	1.5	1.5	1.5	1.5
Isolation	Photocoupler isolation between input terminals and PC power for all base units.					
Response time	For all base units of the MELSEC FX2N series: 10 ms (at time of shipment), partly adjustable between 0 and 15 ms (REFF, FNC51 = 0–60 ms)					
Outputs						
Integrated outputs	40	40	40	40	64	64
Output type	Relay	Relay	Transistor	Transistor	Relay	Transistor
ON voltage (max.)	Generally for relay version: < 250 V AC, < 30 V DC; for transistor version: 5–30 V DC					
Max. output current	- per output	A	2	2	0.5 / 0.8 ^①	0.5 / 0.8 ^①
	- per group*	A	8	8	0.8 / 1.6 ^②	0.8 / 1.6 ^②
Max. switching power	- inductive load	W	80	80	12	12
	- lamp load	W	100	100	1.5	1.5
Response time	ms	10	10	< 0.2	< 0.2	10
Life of contacts (switching times)	For all base units of the MELSEC FX2N series: 3,000,000 at 20 VA; 1,000,000 at 35 VA; 200,000 at 80 VA					
Mechanical data						
Weight	kg	1.2	1.2	1.2	1.8	1.8
Dimensions (W x H x D)	mm	285 x 90 x 87	285 x 90 x 87	285 x 90 x 87	285 x 90 x 87	350 x 90 x 87
Order information						
Art. no.	141286	141287	141289	141288	141290	141292

^① for Y0 and Y1 = 0.3 A; all others 0.5 A ^② 0.8 for 4 per group and 1.6 for 8 per group

* This limitation applies only per reference terminal for each group, 4 and 8 outputs for relays and 2 and 4 outputs for transistors. Please observe the terminal assignments for the group identification.

Digital Inputs/Outputs

Various modular and compact extension units are available for extending the MELSEC FX1N/FX2N base units. In addition, the base units of the FX1S and FX1N series from CPU version 2.0 can be extended by digital inputs and outputs via extension adapters that can be installed directly in the controller. These adapters are especially advantageous when only few additional I/Os are required and when there is not enough space for an adjacent module to be installed.

The modular extension units contain only digital inputs/outputs and no separate power supply, while compact extension units contain a larger number of inputs/outputs and an integrated power supply unit for supplying the system bus and the digital inputs.

The large number of possible combinations of compact and modular extension units of the MELSEC FX1N/FX2N ensure that the best possible economical solution is found for every application.

Owing to the capacity of the internal power supply unit of the respective base unit or of the compact extension unit, modular expandability of the controller is possible with the help of a protected flat cable.

A base unit can be extended by a maximum of 132 (FX1N series) or 256 (FX2N series) external inputs/outputs by means of these extension units.

FX1N and FX2N series extension units can be combined without any problems.

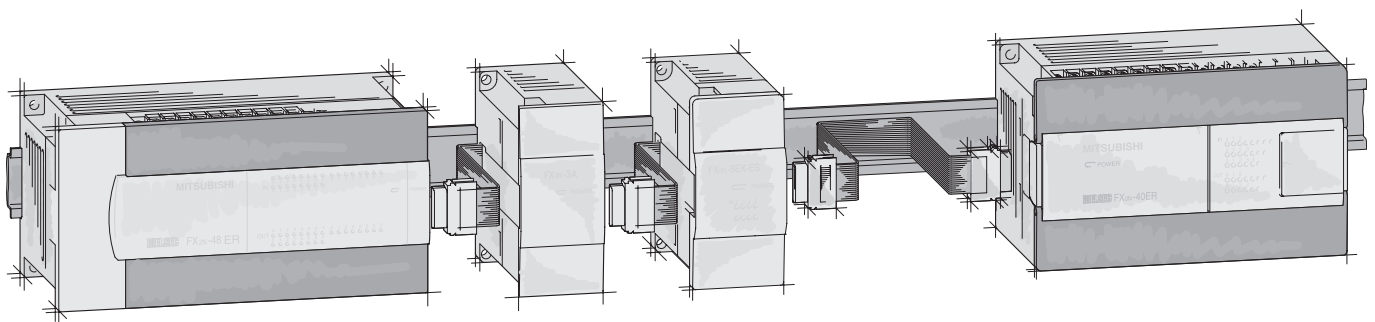

Compact extension units

FX1N FX2N

Module type	Inputs	Outputs	Output type
FX0N-40ER-ES/UL	24	16	Relay
FX0N-40ER-DS	24	16	Relay
FX0N-40ET-DSS	24	16	Transistor

Module type	Inputs	Outputs	Output type
FX2N-32ER-ES/UL	16	16	Relay
FX2N-32ET-ESS/UL	16	16	Transistor
FX2N-48ER-ES/UL	24	24	Relay
FX2N-48ET-ESS/UL	24	24	Transistor
FX2N-48ER-DS	24	24	Relay
FX2N-48ET-DSS	24	24	Transistor

Modular extension units

FX1N FX2N

Module type	Inputs	Outputs	Output type
FX0N-8EX-ES/UL	8	—	—
FX0N-16EX-ES/UL	16	—	—
FX0N-8EYR-ES/UL	—	8	Relay
FX0N-8EYT-ESS/UL	—	8	Transistor
FX0N-16EYR-ES/UL	—	16	Relay
FX0N-16EYT-ESS/UL	—	16	Transistor
FX0N-8ER-ES/UL	4	4	Relay

Module type	Inputs	Outputs	Output type
FX2N-16EX-ES/UL	16	—	—
FX2N-16EYR-ES/UL	—	16	Relay
FX2N-16EYT-ESS/UL	—	16	Transistor

Extension adapters

FX1N FX2N

Type	Inputs	Outputs	Output type
FX1N-4EX-BD	4	—	—
FX1N-2EYT-BD	—	2	Transistor



Compact Extension Units

☑ FX1N ☑ FX2N

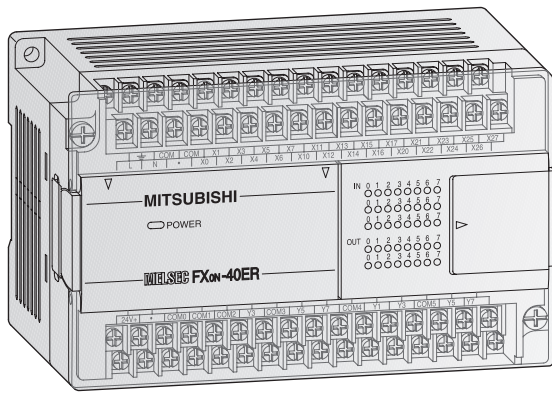

Extension Units FX0N

The FX0N series extension units are available with 40 input/output points.

It is possible to choose between relay and transistor output type.

Special Features:

- LEDs for indicating the input and output status
- MELSEC FX1N/FX2N series compatible
- Integrated service power supply with up to 200 mA capacity

Specifications	FX0N-40 ER-ES/UL	FX0N-40 ER-DS	FX0N-40 ET-DSS
Electrical data			
Integrated inputs/outputs	40	40	40
Power supply	AC range (+10%, -15%)	100 – 240 V	—
	Frequency at AC	Hz 50/60 (±10%)	—
	DC range (+20%, -15%)	—	24 V
Max. input apparent power	40 VA	20 W	20 W
Inrush current at ON	100 V AC	30 A / 5 ms	—
	200 V AC	50 A / 5 ms	—
	24 V DC	—	60 A / 50 μs
Allowable momentary power failure time	ms 10	10	10
External service power supply (24 V DC)	mA 200	—	—
Inputs			
Integrated inputs	24	24	24
Min. current for logical 1	mA 3.5	3.5	3.5
Max. current for logical 0	mA 1.5	1.5	1.5
Response time	For all base units of the MELSEC FX0N series: 10 ms (at time of shipment)		
Outputs			
Integrated outputs	16	16	16
Output type	Relay	Relay	Transistor
Max. switching voltage	Generally for relay version: < 264 V AC, < 30 V DC; for transistor version: 5 – 30 V DC		
Max. output current	- per output	A 2	0.5 / 0.3 ^①
	- per group*	A —	0.8 / 1.6 ^②
Max. switching power	- inductive load	VA 80	12
	- lamp load	W 100	1.5
Response time	ms 10	10	< 0.2
Life of contacts (switching times)	For all extension units of the MELSEC FX0N series: 3,000,000 at 20 VA; 1,000,000 at 35 VA; 200,000 at 80 VA		
Mechanical data			
Weight	kg 0.6	0.6	0.6
Dimensions (W x H x D)	mm 150 x 90 x 87	150 x 90 x 87	150 x 90 x 87
Order information	Art. no. 60012	55955	55954

① for Y0 and Y1 = 0.3 A; all others = 0.5 A ② 0.8 for 4 per group and 1.6 for 8 per group

* This limitation applies only per reference terminal for each group. Please observe the terminal assignments for the group identification.

Compact Extension Units

☑ FX1N ☑ FX2N

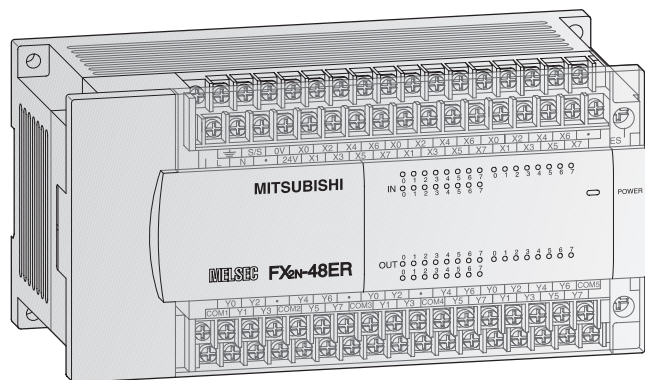

Extension Units FX2N

The FX2N series extension units are available with 32 or 48 input/output points. It is possible to choose between relay and transistor output type.

Special Features:

- LEDs for indicating the input and output status
- MELSEC FX1N/FX2N series compatible
- Detachable terminal blocks
- Integrated service power supply with 250 mA or 460 mA

BASICS



Specifications	FX2N-32 ER-ES/UL	FX2N-32 ET-ESS/UL	FX2N-48 ER-DS	FX2N-48 ER-ES/UL	FX2N-48 ET-DSS	FX2N-48 ET-ESS/UL
Electrical data						
Integrated inputs/outputs	32	32	48	48	48	48
Power supply	AC range (+10 %, -15 %)	100 – 240 V	100 – 240 V	—	100 – 240 V	—
	Frequency at AC	50/60 (±10 %)	50/60 (±10 %)	—	50/60 (±10 %)	—
	DC range (+20 %, -30 %)	—	—	24 V	—	24 V
Max. input apparent power	35 VA	35 VA	30 W	45 VA	30 W	45 VA
Inrush current at ON	100 V AC	50 A < 5 ms	—	50 A < 5 ms	50 A < 5 ms	50 A < 5 ms
	200 V AC	60 A < 5 ms	—	60 A < 5 ms	60 A < 5 ms	60 A < 5 ms
Allowable momentary power failure time	ms	10	10	10	10	10
External service power supply (24 V DC)	mA	250	—	460	—	460
Power supply int. bus (5 V DC)	mA	690	690	690	690	690
Inputs						
Integrated inputs	16	16	24	24	24	24
Min. current for logical 1	mA	3.5	3.5	3.5	3.5	3.5
Max. current for logical 0	mA	1.5	1.5	1.5	1.5	1.5
Response time		For all extension units of the MELSEC FX2N series: 10 ms (at time of shipment)				
Outputs						
Integrated outputs	16	16	24	24	24	24
Output type	Relay	Transistor	Relay	Relay	Transistor	Transistor
ON voltage (max.)	Generally for relay version: < 264 V AC, < 30 V DC; for transistor version: 5 – 30 V DC					
Max. output current	- per output	A	2	0.5 / 0.3 ^①	2	0.5 / 0.3 ^①
	- per group *	A	8	0.8 / 1.6 ^②	8	0.8 / 1.6 ^②
Max. switching power	- inductive load	W	80	12	80	12
	- lamp load	W	100	1.5	100	1.5
Response time	ms	10	< 0.2	10	< 0.2	< 0.2
Life of contacts (switching times)	For all extension units of the MELSEC FX2N series: 3,000,000 at 20 VA; 1,000,000 at 35 VA; 200,000 at 80 VA					
Mechanical data						
Weight	kg	0.65	0.65	0.85	0.85	0.85
Dimensions (W x H x D)	mm	150 x 90 x 87	150 x 90 x 87	182 x 90 x 87	182 x 90 x 87	182 x 90 x 87
Order information						
Art. no.	65568	65569	66633	65571	66634	65572

① for Y0 and Y1 = 0.3 A; all others = 0.5 A ② 0.8 for 4 per group and 1.6 for 8 per group
 * This limitation applies only per reference terminal for each group. Please observe the terminal assignments for the group identification.



Modular Extension Units

☑ FX1N ☑ FX2N

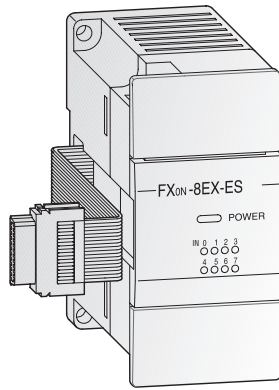

Extension Units FX0N

The FX0N series modular extension units are available with 4, 8 or 16 input/output points.

It is possible to choose between relay and transistor output type.

Special Features:

- LEDs for indicating the input and output status
- MELSEC FX1N/FX2N series compatible
- Vertically (at 8 I/Os) or horizontally mounted (at 16 I/Os) terminal blocks with a cable guide to the upper or lower side

Specifications	FX0N-8 ER-ES/UL	FX0N-8 EX-ES/UL	FX0N-8 EYR-ES/UL	FX0N-8 EYT-ESS/UL	FX0N-16 EX-ES/UL	FX0N-16 EYR-ES/UL	FX0N-16 EYT-ESS/UL		
Electrical data									
Integrated inputs/outputs	8	8	8	8	16	16	16		
Power supply	All modular extension units are supplied by the base unit.								
Inputs									
Integrated inputs	4	8	—	—	16	—	—		
Min. current for logical 1	mA	3.5	3.5	—	3.5	—	—		
Max. current for logical 0	mA	1.5	1.5	—	1.5	—	—		
Response time	For all extension units of the MELSEC FX0N series : 10 ms								
Outputs									
Integrated outputs	4	—	8	8	—	16	16		
Output type	Relay	—	Relay	Transistor	—	Relay	Transistor		
Max. switching voltage	Generally for relay version: < 264 V AC, < 30 V DC; for transistor version: 5 – 30 V DC								
Max. output current	- per output	A	2	—	2	0.5 / 0.3 ^①	—	2	0.5 / 0.3 ^①
	- per group	A	—	—	—	0.8 / 1.6 ^②	—	—	0.8 / 1.6 ^②
Max. switching power	- inductive load	VA	80	—	80	12	—	80	12
	- lamp load	W	100	—	100	1.5	—	100	1.5
Response time	ms	10	10	10	< 0.2	10	10	< 0.2	
Life of contacts (switching times)	For all extension units of the MELSEC FX0N series: 3,000,000 at 20 VA; 1,000,000 at 35 VA; 200,000 at 80 VA								
Mechanical data									
Weight	kg	0.2	0.2	0.2	0.2	0.3	0.3	0.3	
Dimensions (W x H x D)	mm	43 x 90 x 87	43 x 90 x 87	43 x 90 x 87	43 x 90 x 87	70 x 90 x 87	70 x 90 x 87	70 x 90 x 87	
Order information									
Art. no.	60023	60013	60014	60016	55952	55951	55950		

① for Y0 and Y1 = 0.3 A; all others = 0.5 A ② 0.8 for 4 per group and 1.6 for 8 per group

* This limitation applies only per reference terminal for each group. Please observe the terminal assignments for the group identification.

Modular Extension Units

☑ FX1N ☑ FX2N

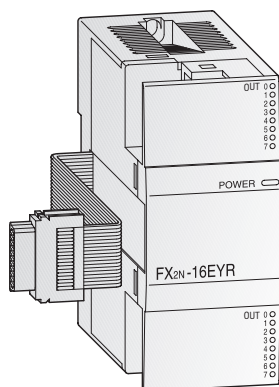

Extension Units FX2N

The FX2N series modular extension units are available with 16 input/output points. It is possible to choose between relay and transistor output type.

Special Features:

- LEDs for indicating the input and output status
- MELSEC FX1N series compatible
- Especially compact design
- Vertically mounted terminal blocks with a cable guide to the upper or lower side

BASICS



Specifications	FX2N-16 EX-ES/UL	FX2N-16 EYR-ES/UL	FX2N-16 EYT-ESS/UL
Electrical data			
Integrated inputs/outputs	16	16	16
Power supply	All modular extension units are supplied by the base unit.		
Inputs			
Integrated inputs	16	—	—
Min. current for logical 1	mA 3.5	—	—
Max. current for logical 0	mA 1.5	—	—
Response time	For all base units of the MELSEC FX2N series: 10 ms (at time of shipment)		
Outputs			
Integrated outputs	—	16	16
Output type	—	Relay	Transistor
ON voltage (max.)	V Generally for relay version: < 264 V AC, < 30 V DC; for transistor version: 5 – 30 V DC		
Max. output current	- per output	A —	2
	- per group	A —	—
Max. switching power	- inductive load	VA —	80
	- lamp load	W —	100
Response time	ms —	10	< 0.2
Life of contacts (switching times)	—	Same as base unit	—
Mechanical data			
Weight	kg 0.3	0.3	0.3
Dimensions (W x H x D)	mm 40 x 90 x 87	40 x 90 x 87	40 x 90 x 87
Order information	Art. no. 65776	65580	65581

① for Y0 and Y1 = 0.3 A; all others = 0.5 A ② 0.8 for 4 per group and 1.6 for 8 per group

* This limitation applies only per reference terminal for each group. Please observe the terminal assignments for the group identification.

Extension Adapter Boards

FX1N FX2N

BASICS

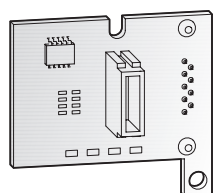
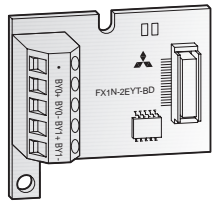

Extension adapter FX1N

The extension adapters of the FX1N series are available with 4 inputs or 2 outputs. They are installed directly in the controller of the FX1S or FX1N series and therefore do not require any additional installation space.

These adapters are especially advantageous when only few additional I/Os are required and there is not enough room for an adjacent module to be installed.

Special Features:

- Due to the installation directly in the controller no modifications on the installation site are required.
- Compatible with the MELSEC FX1S and FX1N series (from CPU version 2.00)
- No I/O points occupied
- Inputs and outputs are controlled via special relays
- I/O status is indicated via LEDs
- Common use with FX1N-5DM

Specifications	FX1N-4EX-BD	FX1N-2EYT-BD
Electrical data		
Integrated inputs/outputs	4	2
Power supply	Via base unit	Via base unit
Inputs		
Integrated inputs	4	—
Input level	voltage	24 V DC (+20 % / -10 %)
	current	~ 5 mA (24 V DC)
Min. current for logical 1	mA 3.5	—
Max. current for logical 0	mA 1.5	—
Response time	10 ms (factory adjusted)	—
Outputs		
Integrated outputs	—	2
Output type	—	Transistor
Max. switching voltage	V —	5 – 30 V DC
Max. output current	- per output	A —
	- per group	A —
Max. switching power	- inductive load	VA —
	- lamp load	W —
Leakage current	mA —	0.1 / 30 V DC
Response time	ms —	0.2
Mechanical data		
Weight	kg 0.02	0.02
Dimensions (W x H x D)	mm 43 x 38.5 x 22	43 x 38.5 x 22
Order information	Art. no. 139418	139420

■ Analog Setpoint Adapters FX1N-8AV-BD and FX2N-8AV-BD

☑ FX1N ☑ FX2N

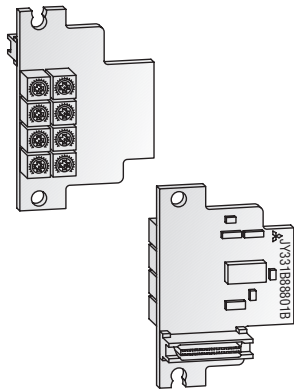

The FX□N-8AV-BD analog setpoint adapters enable the user to set 8 analog setpoint values. The analog values of the potentiometers are read into the controller and used as default setpoint values for timers, counters and data registers by the user's PLC programs.

Setpoint value polling and the definition of the potentiometer scales are performed in the PLC program using the dedicated instructions VRRD/VRSC (FNC85/86).

The FX□N-8AV-BD analog setpoint adapters are installed in the expansion slot of the FX1N/ FX2N CPU. No additional power supply is

Specifications	FX1N-8AV-BD	FX2N-8AV-BD
Applicable for	Base units FX1S/FX1N	Base units FX2N
General specifications	Conforms to FX1N/FX2N base units	
Power supply	From base unit	From base unit
Adjusting range	8 bit	8 bit
Related I/O points	0	0
Potentiometer evaluation	Via application instruction from the PLC CPU (FNC 85/86)	
Weight	kg	0.02
Dimensions (W x H x D)	mm	43 x 38.5 x 22
Order information		
Art. no.	130744	65594

■ Analog Adapter Board FX1N-2AD-BD

☑ FX1N ☐ FX2N

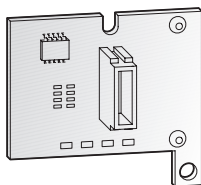
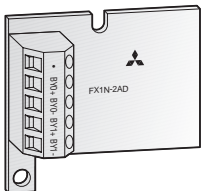

The analog input adapter board FX1N-2AD-BD provides the user with 2 analog inputs. The board converts analog process signals into digital values which are further processed by the MELSEC FX1N/FX2N controller (for CPU version 2.00).

The actual values or mean values over several measurements may be output. The adapter is inserted into the extension slot of the FX1S or FX1N CPU. An additional power supply is not required for operation.

Specifications	FX1N-2AD-BD	
General specifications	Conforms to FX1N/FX2N base units	
Power supply	From base unit	
Analog channels	Inputs: 2 Outputs: —	
Analog input range	0 – +10 V DC / 4 – +20 mA	
Input resistance	Voltage input: kΩ 300 Current input: Ω 250	
Resolution	2.5 mV / 8 μA (11 bits + sign)	
Overall accuracy	±1 %	
Conversion speed	Analog → Digital: 1 program cycle Digital → Analog: ms —	
Related I/O points	0	
Weight	kg 0.02	
Dimensions (W x H x D)	mm 43 x 38.5 x 22	
Order information		
Art. no.	139421	



Analog Adapter Board FX1N-1DA-BD

FX1N FX2N

BASICS

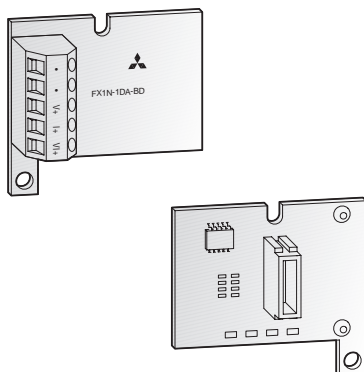

The analog adapter FX1N-1DA-BD provides the user with 1 analog output. The module converts digital values from the FX1N/FX2N controller (from version 2.00) to the analog signals required by the process.

The analog adapter can output both current and voltage signals.

The adapter is inserted into the extension slot of the FX1S or FX1N CPU. An additional power supply is not required for operation.

Specifications		FX1N-1DA-BD	
General specifications		Conforms to FX1N/FX2N base units	
Power supply		From base unit	
Analog channels	Inputs	—	
	Outputs	2	
Analog output range		0 – +10 V DC / 4 – +20 mA	
External load	Voltage output	2 k Ω – 1 M Ω	
	Current output	< 500 Ω	
Resolution		2.5 mV / 8 μ A (11 bits + sign)	
Overall accuracy		\pm 1 %	
Conversion speed	Analog \rightarrow Digital	ms	—
	Digital \rightarrow Analog	ms	1 program cycle
Related I/O points		0	
Weight		kg	0.02
Dimensions (W x H x D)		mm	43 x 38.5 x 22
Order information		Art. no.	139422

Analog Input/Output Module FX0N-3A

FX1N FX2N

BASICS

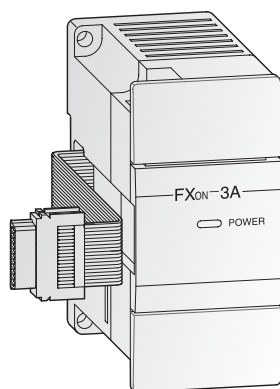

The analog input/output module FX0N-3A provides the user with 2 analog inputs and 1 analog output. They serve for conversion of analog process signals into digital values, and vice versa.

The analog input/output module is connected to the base unit via a protected flat cable. The connection is to the extension bus on the right side of the controller.

Specifications		FX0N-3A	
General specifications		Conforms to FX1N/FX2N base units	
Dielectric withstand voltage		500 V AC for 1 minute	
Power supply		24 V DC / 90 mA (from base unit), 5 V DC / 30 mA	
Number of analog points	Inputs	2	
	Outputs	1	
Analog data	Voltage	V	0 – +10 V DC / 0 – +5 V DC
	Current	mA	4 – +20 mA
I/O resolution		20 mV / 64 μ A (8 bit)	
Total accuracy		\pm 1 %	
Conversion time	A \rightarrow D / D \rightarrow A	ms	0.1 / point
Related I/O points		8	
Weight		kg	0.2
Dimensions (W x H x D)		mm	43 x 90 x 87
Order information		Art. no.	41790

■ Analog Output Module FX2N-2DA

☑ FX1N ☑ FX2N

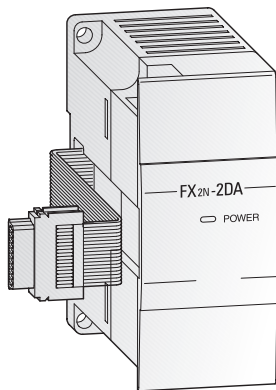

The analog output module FX2N-2DA provides the user with 2 analog outputs. The modules convert digital values from the FX1N/FX2N controller to the analog signals required by the process.

The module can output both current and voltage signals.

Specifications		FX2N-2DA	
General specifications		Conforms to FX1N/FX2N base units	
Power supply		5 V DC / 30 mA (from base unit), 24 V DC / 85 mA	
Analog channels	Inputs	—	
	Outputs	2	
Analog output range		0 – +10 V DC / 0 – +5 V DC / 4 – +20 mA	
External load	Voltage output	2 k Ω – 1 M Ω	
	Current output	< 500 Ω	
Resolution		2.5 mV / 4 μ A (11 bit + sign)	
Overall accuracy		\pm 1 %	
Conversion speed	Analog \rightarrow Digital	ms	—
	Digital \rightarrow Analog	ms	4 per channel
Related I/O points		8	
Weight		kg	0.2
Dimensions (W x H x D)		mm	43 x 90 x 87
Order information		Art. no.	102868

■ Analog Input Module FX2N-2AD

☑ FX1N ☑ FX2N

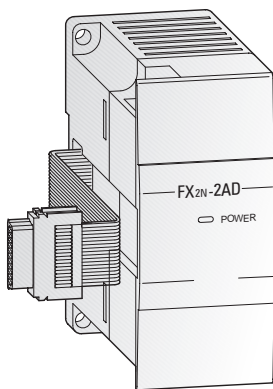

The analog input module FX2N-2AD provides the user with 2 analog inputs. The module converts analog process signals into digital values which are further processed by the MELSEC FX1N/FX2N controller.

The actual values or mean values over several measurements may be output.

Specifications		FX2N-2AD	
General specifications		Conforms to FX1N/FX2N base units	
Power supply		5 V DC / 20 mA (from base unit), 24 V DC / 50 mA	
Analog channels	Inputs	2	
	Outputs	—	
Analog input range		0 – +10 V DC / 0 – +5 V DC / 4 – +20 mA	
Input resistance	Voltage input	k Ω	200
	Current input	Ω	250
Resolution		5 mV / 20 μ A (11 bit + sign)	
Overall accuracy		\pm 1 %	
Conversion speed	Analog \rightarrow Digital	ms	2.5 per channel
	Digital \rightarrow Analog	ms	—
Related I/O points		8	
Weight		kg	0.2
Dimensions (W x H x D)		mm	43 x 90 x 87
Order information		Art. no.	102869

BASICS



Analog Output Module FX2N-4DA

☑ FX1N ☑ FX2N

BASICS

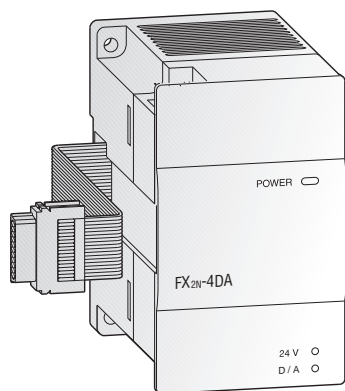

The analog output module FX2N-4DA provides the user with 4 analog outputs. The modules convert digital values from the FX1N/FX2N controller to the analog signals required by the process.

The modules can output both current and voltage signals.

Specifications		FX2N-4DA	
General specifications		Conforms to FX1N/FX2N base units	
Power supply		5 V DC / 30 mA (from base unit), 24 V DC / 200 mA	
Analog channels	Inputs	—	
	Outputs	4	
Analog output range		-10 – +10 V DC / 0 – +20 mA / 4 – +20 mA	
External load	Voltage output	2 kΩ – 1 MΩ	
	Current output	< 500 Ω	
Resolution		5 mV / 20 μA (11 bit + sign)	
Overall accuracy		±1 %	
Conversion speed	Analog → Digital	ms	—
	Digital → Analog	ms	2.1 for 4 channels
Related I/O points		8	
Weight		kg	0.3
Dimensions (W x H x D)		mm	55 x 90 x 87
Order information		Art. no.	65586



Analog Input Module FX2N-4AD

☑ FX1N ☑ FX2N

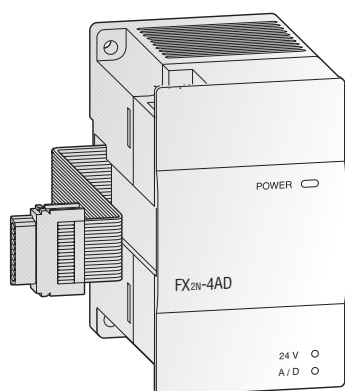

The analog input module FX2N-4AD provides the user with 4 analog inputs. The module converts analog process signals into digital values which are further processed by the FX1N/FX2N controller.

The actual values or mean values over several measurements may be output.

Specifications		FX2N-4AD	
General specifications		Conforms to FX1N/FX2N base units	
Power supply		5 V DC / 30 mA (from base unit), 24 V DC / 50 mA	
Analog channels	Inputs	4	
	Outputs	—	
Analog input range		-10 – +10 V DC / -20 – +20 mA / 4 – +20 mA	
Input resistance	Voltage input	kΩ	200
	Current input	Ω	250
Resolution		5 mV / 20 μA (11 bit + sign)	
Overall accuracy		±1 %	
Conversion speed	Analog → Digital	15 per channel / 6 per channel (high speed)	
	Digital → Analog	ms	—
Related I/O points		8	
Weight		kg	0.3
Dimensions (W x H x D)		mm	55 x 90 x 87
Order information		Art. no.	65585

■ Analog Input Module FX2N-8AD

☑ FX1N ☑ FX2N

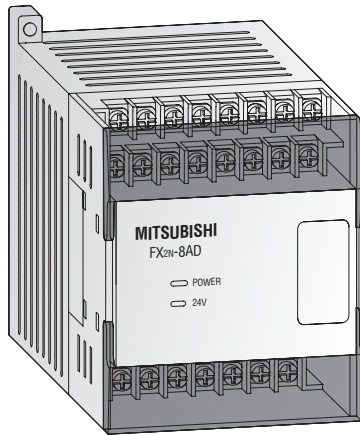

The high-resolution FX2N-8AD analog input module converts 8 points of analog input values into digital values, and transfers them to the PLC base unit.

Analog inputs can be selected from the voltage input, the current input and the thermocouple input (temperature input) by the input mode setting by the TO instruction given by the PLC base unit and the connection method.

Specifications		FX2N-8AD	
General specifications		Conforms to FX1N/FX2N base units	
Power supply		5 V DC / 50 mA (from base unit), 24 V DC / 80 mA	
Analog channels	Inputs	8	
	Outputs	—	
Analog input range		-10 – +10 V DC / -20 – +20 mA / 4 – +20 mA	
Input resistance	Voltage input	kΩ	200
	Current input	Ω	250
Resolution		0.63 – 2.5 mV / 2.0 – 5.0 μA (16 bit)	
Overall accuracy		±1 %	
Conversion speed	Analog → Digital	500 μs per channel / 40 ms with thermo element	
	Digital → Analog	ms	—
Integrated memory		EEPROM	
Related I/O points		8	
Weight		kg	0.3
Dimensions (W x H x D)		mm	75 x 105 x 75
Order information		Art. no.	129195



■ Analog Input Module for Thermocouples FX2N-4AD-TC

☑ FX1N ☑ FX2N

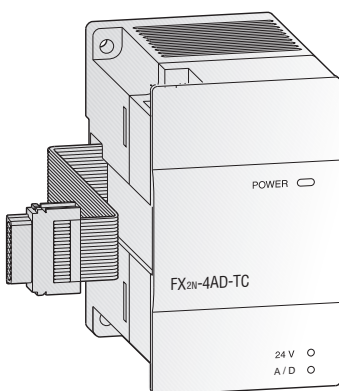

The analog input module for thermocouples FX2N-4AD-TCC is used for processing temperatures. It has 4 independent inputs for detecting signals from thermocouples of types J and K. The type of thermocouple can be chosen independently for each point.

buffer memory, in the module and then converted. It is also possible to calculate a mean value from a predetermined number of measurements in order to obtain stable digital results.

The electrical magnitude at an input is converted into a digital numerical value with a sign. The converted value is stored by the PLC in a memory address, so-called

The number of measurements must be transferred by the PLC program to a buffer memory of the special function module. The value determined is available in another memory address.

Specifications		FX2N-4AD-TC	
General specifications		Conforms to FX1N/FX2N base units	
Power supply		5 V DC / 30 mA (from base unit), 24 V DC / 50 mA	
Analog inputs		4 (J or K type)	
Compensated temperature range	°C	-100 – +600 (J type) / -100 – +1200 (K type)	
Digital output		-1000 – +6000 (J type) / -1000 – +12000 (K type)	
Resolution	°C	0.3 (J type) / 0.4 (K type)	
Overall accuracy		±0.5 %	
Conversion speed	ms	240 per channel (±2 %)	
Related I/O points		8	
Weight	kg	0.3	
Dimensions (W x H x D)	mm	55 x 90 x 87	
Order information		Art. no.	65588



Analog Input Module for Pt100 Inputs FX2N-4AD-PT

☑ FX1N ☑ FX2N

BASICS

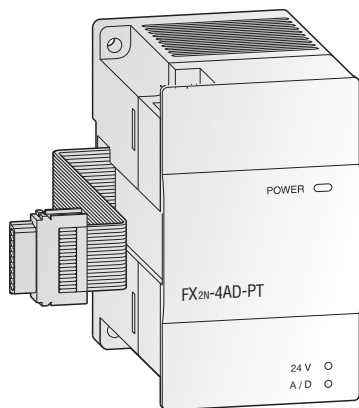

The analog input module for Pt100 inputs FX2N-4AD-PT permits the connection of four Pt100 sensors to the FX1N/FX2N series controller.

The respective temperatures can be read out either in °C or °F.

Specifications	FX2N-4AD-PT
General specifications	Conforms to FX1N/FX2N base units
Power supply	5 V DC / 30 mA (from base unit), 24 V DC / 50 mA
Analog inputs	4 (Pt100 sensors)
Compensated temperature range	°C -100 – +600
Digital output	-1,000 – 6,000 (12 bit conversion)
Resolution	°C 0.2
Overall accuracy	±1 % over full linear range
Conversion speed	ms 15 for 4 channels
Related I/O points	8
Weight	kg 0.3
Dimensions (W x H x D)	mm 55 x 90 x 87
Order information	Art. no. 65587



Temperature Control Module FX2N-2LC

☑ FX1N ☑ FX2N

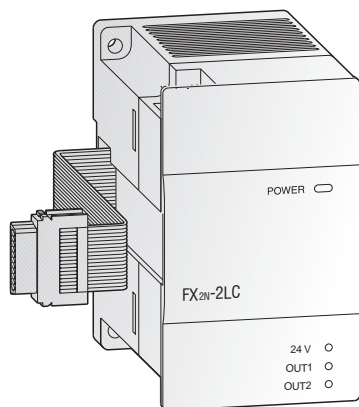

The temperature control module FX2N-2LC is equipped with two temperature input points and two transistor (open collector) output points. It is used to read temperature signals from thermocouples and platinum resistance thermometer bulbs, and performs PID output control.

Data can be written and read using FROM/TO instructions. It is not necessary to create a special sequence program for PID operation, since the FX2N-2LC performs arithmetic operation for PID control and output control by itself.

The proportional band, the integral time and the derivative time can be easily set by the integrated autotuning function.

Specifications	FX2N-2LC
General specifications	Conforms to FX1N/FX2N base units
Power supply	5 V DC / 70 mA (from base unit) 24 V DC / 55 mA
Number of input points	2 points
Number of output points	2 transistor output points
Temperature control method	Two-position control, PID control (with autotuning), PI control
Sampling period	0.5 s / channel
Set temperature range	Equivalent to the input range of the thermocouple used
Supported thermocouples	Pt100, JPt100, K, J, R, S, E, T, B, N, PLII, WRe5=26, U, L
Measurement precision	±0.7 % (±0.3 % when ambient temperature is 23 °C ±5 °C)
Resolution	0.1 °C or 1 °C
Related I/O points	8
Weight	kg 0.25
Dimensions (W x H x D)	mm 55 x 90 x 87
Order information	Art. no. 129196

High-Speed Counter FX2N-1HC

FX1N FX2N

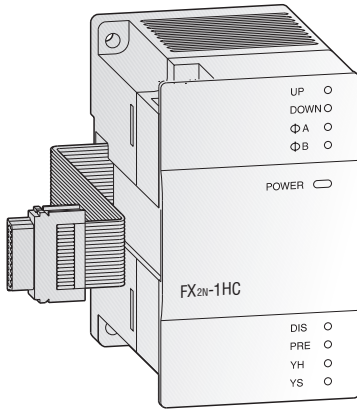

In addition to the internal high-speed MELSEC FX counters, the high-speed counter module FX2N-1HC provides the user with an external hardware counter. It counts 1- or 2-phase pulses up to a frequency of 50 kHz. The counting range covers either 16 or 32 bit.

The two integrated transistor outputs can be switched independently of one another by means of internal comparison functions. Hence, simple positioning tasks can also be realized economically. In addition, the FX2N-1HC can be used as a ring counter.

Specifications	FX2N-1HC	
General specifications	Conforms to FX1N/FX2N base units	
Signal level	5, 12, 24 V DC / 7 mA	
Power supply	5 V DC / 90 mA (from base unit)	
Counter inputs	2 (1 phase) or 1 (2 phase)	
Max. counting frequency	kHz	50
Input format	bit	16, 32
Type of counter	Up/down counter, ring counter	
Counting range	16 bit	-2147483648 – +2147483647
	32 bit	0 – 65535
Output type	2 x transistor (5 – 24 V DC; 0.5 A)	
Related I/O points	8	
Weight	kg	0.3
Dimensions (W x H x D)	mm	55 x 90 x 87
Order information	Art. no.	65584

Single-Axis Positioning Modules FX2N-1PG-E and FX2N-10PG

FX1N FX2N

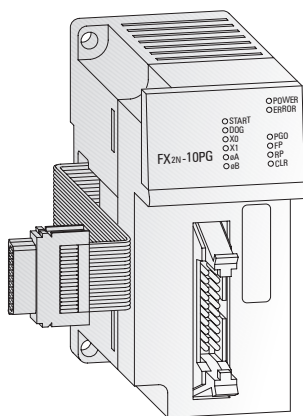

The positioning modules FX2N-1PG-E and FX2N-10PG are extremely efficient single-axis positioning modules for controlling either step drives or servo drives (by external regulator) with a pulse chain. It is very suitable for achieving accurate positioning in combination with the MELSEC FX series. The configuration and allocation of the position data are carried out directly via the PLC program.

A very wide range of manual and automatic functions are available to the user.

Further special features are:

- Possibility of absolute or relative positioning
- 7 different operation functions, such as jog mode, zeroing, variable speeds, etc.
- Separate programming units and operator panels are not required.
- The speed increase or decrease can be set either automatically or manually.

Specifications	FX2N-1PG-E	FX2N-10PG
General specifications	Conforms to FX1N/FX2N base units	
Signal level for digital inputs	24 V DC / 7–40 mA	24 V DC / 6–20 mA
Power supply	5 – 24 V DC / 60 mA	5 – 24 V DC / 70 mA
Accessible axes	1	1
Output frequency	pulse/s	
	10 – 100 000	1 – 1 000 000
Related I/O points	8	8
Weight	kg	0.2
Dimensions (W x H x D)	mm	43 x 90 x 87
Order information	Art. no.	65583 140113

BASICS



Positioning Modules FX2N-10GM and FX2N-20GM

FX1N FX2N

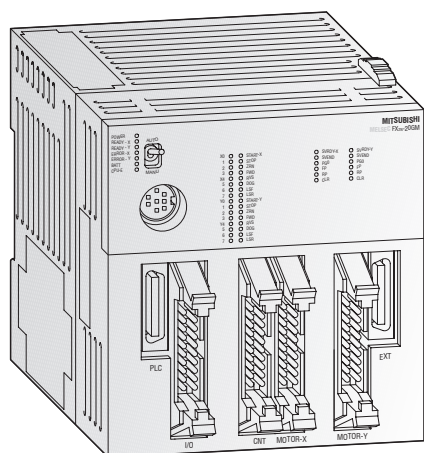

1-axis or 2-axes positioning modules

The FX2N-10GM and FX2N-20GM positioning modules are pulse chain output units that enable the positioning control of stepping motors or servo motors via the drive unit.

The comfortable programming software allows even newcomers to realize complicated positioning tasks in an easy way.

Travel units, handling devices and processing lines with fixed or variable strokes are supported by simple programs for different positioning applications.

Special Features:

- Can be used as a stand-alone device or in combination with an FX2N PLC
- Up to 8 FX2N-10GM and/or FX2N-20GM can be connected to an FX2N PLC
- Pulse generator connection possible
- Data communication with the PLC via simple FROM/TO instructions
- Linear and circular interpolation are available
- Integrated inputs and outputs (connection possible with external terminal block)
- Additional inputs/outputs can be added
- Easy to use programming software (art. no. 128776)

Specifications	FX2N-10GM	FX2N-20GM
Number of controllable axes	1 axis	2 axes (independently or simultaneously)
Program memory	3.8 K steps with EEPROM	7.8 K steps with built-in RAM (battery backup): EEPROM optionally
Positioning	method	Absolute data or incremental
	units	mm, inch, degree and pulse
	counting resolution	31 bits + sign, -2147483648 to 2147483647
	max. counting frequency	200 kHz
speed	1,530,000 mm/min.	1,530,000 mm/min.
Zero return	Manual operation or automatic operation	Manual operation or automatic operation
Absolute position detection	The detection is possible with MELSERO MR-J2 and MR-C	
Control inputs	operation system	FWD - manual forwarding, RVS - manual reversal, ZRN - machine zero return, START - automatic start, STOP - stop positioning, manual pulse generator (2 kHz max.), single-step operation input (depends upon the parameter setting)
	mechanical system	DOG - near point signal, LSF - forward rotation limit, LSR - reverse rotation limit, interrupt signal (4 points)
	servo system	SVRDY - servo ready, SVEND - servo end, PGO - zero-point signal
	general purpose	Digital inputs X0 to X3
Control outputs	servo system	FP - forward rotation pulse, RP - reverse rotation pulse, CLR - counter clear
	general purpose	Digital outputs Y0 to Y5
Self-diagnosis	"Parameter error", "program error" and "external error" can be diagnosed by the display and the error codes	
Power supply	24 V DC (-15 % to +10 %)	24 V DC (-15 % to +10 %)
Power consumption	5 W	10 W
General specifications	Conforms to FX2N base units	
Weight	kg	kg
Dimensions (W x D x H)	mm	mm
Order information	Art. no. 128889	127016
Accessories	Terminal block for I/O extension of the positioning unit: Flat cable to connect I/O equipment/terminal block: FX-16E-TB/UL, art. no.: 125189; FX-16E-150CAB, art. no.: 125584; FX-16E-500CAB, art. no.: 130451 Cable to connect servo amplifier MR-C: E-GMC-200CAB, art. no.: 128731 Cable to connect servo amplifier MR-J2: E-GMJ2-200CAB1A, art. no.: 125583 Cable to connect servo amplifier general-purpose drive unit: E-GM-200CAB, art. no.: 130450 Programming software: FX-PCS-VPS/WIN-E, art. no.: 128776 Spare battery (FX2N-20GM only): FX2NC-32BL, art. no.: 128725 FX-32E-TB/UL, art. no.: 128724 FX16E-300CAB, art. no.: 128722;	

■ Active Data Interface Module FX0N-232ADP

☑ FX1N ☑ FX2N

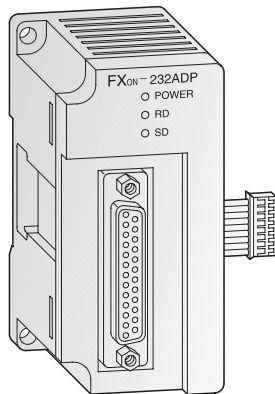

The additional active data interface module FX0N-232ADP permits active communication between the PLC and surrounding RS232C peripherals. All operands can be sent or received via this interface.

Devices can be transmitted via this interface. A program transfer or the connection of a MAC terminal is not possible.

The module is suitable for the connection of printers, bar code readers, PCs and other PLC systems. The communication is handled by the PLC program using the RS instruction.

The connection is to the communications bus on the left side of the controller. The internal serial RS422 interface is also fully available.

Specifications		FX0N-232ADP
General specifications		Conforms to FX1N/FX2N base units
Interface		RS232C with 25 pole D-SUB compact plug (photocoupler isolated)
Power supply		5 V DC / 200 mA (from base unit)
Communication speed	bit/s	300, 600, 1200, 2400, 4800, 9600, 19200
Communication distance	m	Max. 15
Communication cable		Shielded cable
Communication mode		Half duplex
Protocols		Non-protocol mode / free programmable via PLC
Format		7 or 8 bits, parity 1 or 0, 1 or 2 stop bit
Related I/O points		—
Weight	kg	0.2
Dimensions (W x H x D)	mm	43 x 90 x 68
Order information		Art. no. 42211

■ Interface Module FX2N-232IF

☑ FX1N ☑ FX2N

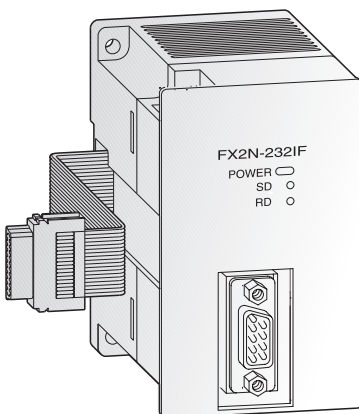

The interface module FX2N-232IF module provides an RS232C interface for serial data communications with the MELSEC FX1N and FX2N.

Communication with PCs, printers, modems, barcode readers etc. is handled

by the PLC program using FROM/TO instructions.

The send and receive data are stored in the FX2N-232IF's own buffer memory.

Changes at the user program are not possible via this interface module.

Specifications		FX2N-232IF
General specifications		Conforms to FX1N/FX2N base units
Interface		RS232C with 9 pole D-SUB connector (photocoupler isolation)
Power supply		5 V DC / 40 mA (from base unit), 24 V DC / 80 mA
Communication speed	Bit/s	300, 600, 1200, 2400, 4800, 9600, 19200
Communication distance	m	Max. 15
Communication cable		Shielded cable
Communication mode		Full duplex
Protocols		Non protocol mode / start stop synchronisation
Send and receive buffer		512 byte each
Format		7 or 8 data bits, parity 1 or 0, 1 or 2 stop bit
Related I/O points		8
Weight	kg	0.3
Dimensions (W x H x D)	mm	55 x 90 x 85
Order information		Art. no. 66640

BASICS



Interface Adapters FX1N-232BD and FX2N-232BD

☑ FX1N ☑ FX2N

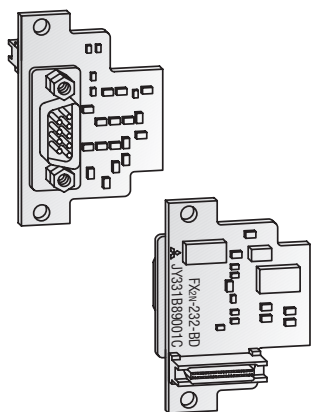

The FX□N-232BD interface adapters provide an RS232C interface for serial data communications with the MELSEC FX1N/FX2N.

Data and programmes can be transferred with the standard RS232 protocol. The unit's integrated automatic parameter setting facility also makes it possible to configure a modem – for example for remote programming and maintenance tasks.

Data can be transferred directly to other serial peripherals using the RS dedicated instruction. Connected programming systems are identified automatically.

The adapter board is installed in the expansion slot provided for it in the FX1N/FX2N base unit.

If the interface adapter is used no other adapters can be used.

Specifications	FX1N-232BD	FX2N-232BD
Applicable for	Base units FX1S/FX1N	Base units FX2N
General specifications	Conforms to FX1N/FX2N base units	
Interface	RS232C with 9 pole D-SUB connector	
Power supply	5 V DC / 60 mA (from base unit)	
Communication speed	Bit/s	300, 600, 1200, 2400, 4800, 9600, 19200
Communication distance	m	Max. 15
Communication mode	Half duplex	
Protocols	Free programmable via PLC / non-protocol mode / protocol 1 or 4	
Related I/O points	—	—
Weight	kg	0.02
Dimensions (W x H x D)	mm	43 x 38,5 x 22
Order information	Art. no.	130743
		65596

Interface Adapters FX1N-422BD and FX2N-422BD

☑ FX1N ☑ FX2N

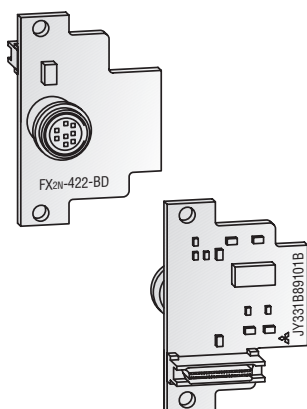

The FX□N-422BD interface adapters provide a second RS422 interface for connection of an additional device to the controller (programming unit or operator terminal).

In addition to programming the PLC the main applications for this interface include production data logging, process visualisation and man-machine communication.

If one programming unit is already connected to the integrated RS422 interface it is not possible to connect a second one to the FX2N-422BD interface adapter. It is possible to connect two control units, however.

The interface adapter is installed in the expansion slot provided for it in the FX1N/FX2N base unit.

No additional adapter boards can be used when this interface adapter is installed.

Specifications	FX1N-422BD	FX2N-422BD
Applicable for	Base units FX1S/FX1N	Base units FX2N
General specifications	Conforms to FX1N/FX2N base units	
Interface	RS422 with 8 pole mini DIN connector	
Power supply	5 V DC / 60 mA (from base unit)	
Communication distance	m	Max. 15
Communication mode	Half duplex	
Protocols	Free programmable via PLC	
Related I/O points	—	—
Weight	kg	0.01
Dimensions (W x H x D)	mm	43 x 38,5 x 20
Order information	Art. no.	130741
		65595

The PROFIBUS/DP Network

Features

The open PROFIBUS/DP network enables extremely fast data exchange with a very wide variety of slave devices, including:

- Remote digital I/Os
- Remote analog I/Os
- Remote intelligence PLC (FX1N, FX2N)
- Frequency inverters (FR-A 540(L-G), FR-E 500 and FR-F500)
- Operator terminals (MAC E)
- A range of other devices from third-party manufacturers

Structure

The maximum coverage of a bus segment is 1,200 m (at a maximum of 93.75 kbit/s). Up to 3 repeaters are allowed. Thus the maximum distance between 2 stations is calculated with 4,800 m.

Cable Types

To help reduce costs PROFIBUS/DP uses RS485 technology with simple twisted-pair cabling.

Suitable cables include the UNITRONIC BUSLD from Lappkabel and the DUE 4451 from Alcatel.

Data Exchange

The PROFIBUS/DP master modules A(1S)J71PB92D and QJ71PB92D support slave device data exchange with up to 244 send bytes and 244 receive bytes. This means you can exchange a total of up to 488 bytes with a slave unit per network cycle.

Administration

In combination with the GX Configurator DP configuration software the A1SJ71PB92D or QJ71PB92D PROFIBUS/DP masters give you user-friendly plug-and-play technology. The configuration software GX Configurator DP is self-explanatory, using a graphical model for setting up the network. You simply select the slave unit (e.g. FX2N), assign the station numbers and specify where the information is stored in the master CPU.

Please refer to page 86 for further information about the software.

Of course, PROFIBUS/DP slaves from MITSUBISHI ELECTRIC can also be connected to master devices from other manufacturers.

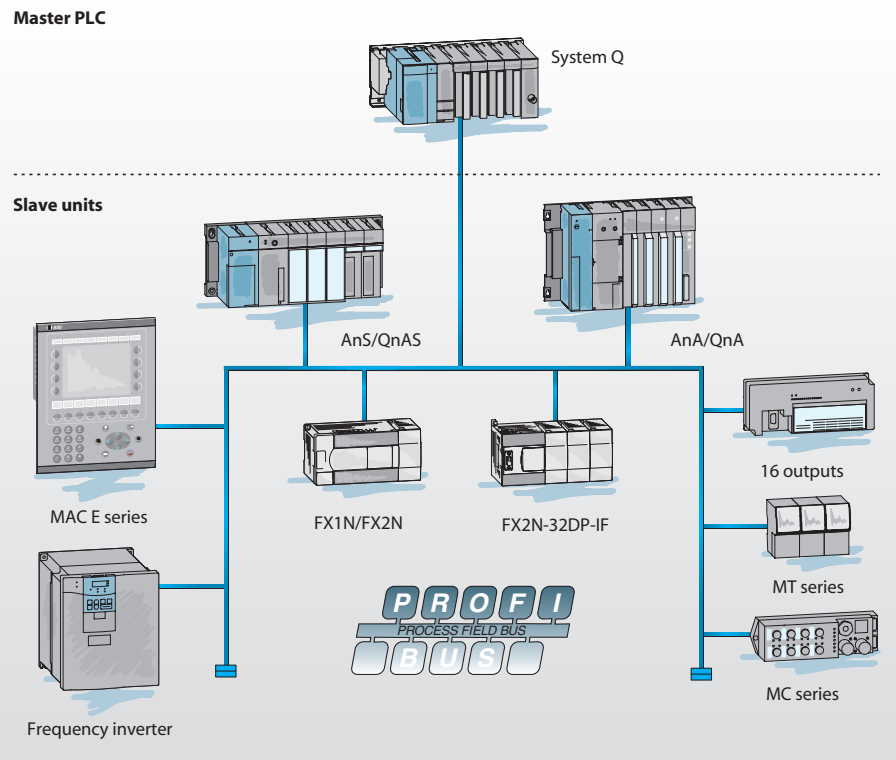

Specifications		Master AJ71PB92D	Master A1SJ71PB92D	Master QJ71PB92D
Application range		MELSEC AnU/QnA	MELSEC AnS/QnAS	System Q
Communications protocol		EN 50170 / DIN 19245-T3		
Cabling		Shielded twisted-pair with 24 AWG = 0.22 mm ² , impedance: 100 – 130 Ω; Shielded twisted-pair with 22 AWG = 0.34 mm ² , impedance: 135 – 165 Ω		
Interface		RS485		
Communications speed	distance			
	1.200	kbit/s	9,6 / 19,2 / 93,75	
	1.000	kbit/s	187,5	
	400	kbit/s	500	
	200	kbit/s	1.500	
	100	kbit/s	12.000	12.000 / 6.000 / 3.000
Max total distance	m	4.800 (3 repeaters)	4.800 (3 repeaters)	4.800 (3 repeaters)
Slave units per master		60	60	60
Stations per segment		32	32	32
Repeaters per network		Max. 3	Max. 3	Max. 3
Order information	Art. no.	53661	63393	134931
Accessories		ProfiConT: PROFIBUS 9-pin D-SUB plug connector for up to 12 Mbaud with terminator; art. no. 87035		

Please refer to the technical networks catalogue for further informations about master, slave and remote modules.



■ PROFIBUS/DP Slave Module FX0N-32NT-DP

☑ FX1N ☑ FX2N

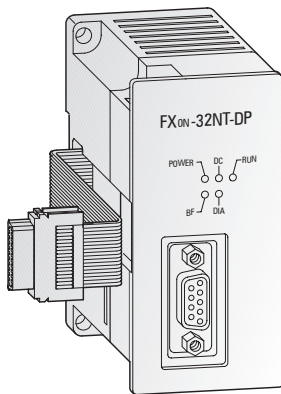

The FX0N-32NT-DP PROFIBUS/DP slave module enables you to integrate a MELSEC FX1N/ FX2N in an existing PROFIBUS/DP network.

This interface module provides your FX1N or FX2N CPU with an intelligent

PROFIBUS/DP link for the implementation of decentralised control tasks.

It links the system to the master PLC in the PROFIBUS/DP network for efficient and trouble-free data exchange.

Specifications		FX0N-32NT-DP	
General specifications		Conforms to FX1N/FX2N base units	
Power supply		5 V DC / max. 170 mA (from base unit), 24 V DC / 60 mA	
Interface		PROFIBUS/DP (with 9 pole D-SUB connector)	
Communication speed	distance		
	1,200 m	kbit/s	9.6 / 19.2 / 93.75
	1,000 m	kbit/s	187.5
	200 m	kbit/s	1500
	100 m	kbit/s	3,000 / 6,000 / 12,000
Communication distance		m	Max. 1,200 (depends on communication speed)
Communication cable		PROFIBUS cable with 9-pin D-SUB connector	
Related I/O points		8	
Weight		kg	0.3
Dimensions (W x H x D)		mm	43 x 90 x 87
Order information		Art. no.	62125

■ Remote I/O Station FX2N-32DP-IF for PROFIBUS/DP

☑ FX1N ☑ FX2N

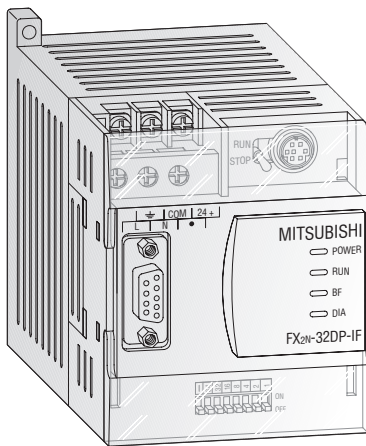

The remote I/O station FX2N-32DP-IF forms an extremely compact communication unit and provides a connection of I/O modules with up to 256 I/O points or up to 8 special function modules as an alternative.

It features an entire electrical isolation of the PROFIBUS/DP connector and of the sensor/actuator circuits.

The FX2N-32DP-IF includes a 230 V power supply unit and a 24 V service voltage terminal, e.g. for analog modules. The FX2N-32DP-IF-D is supplied with 24 V DC.

Profibus data such as the baud rate can be monitored directly on the hand-held programming unit FX-20P-E. This facilitates an easy error diagnosis directly on the remote I/O station.

Specifications		FX2N-32DP-IF	FX2N-32DP-IF-D
General specifications		Conforms to FX1N/FX2N base units	
Power supply		100 – 240 V AC (+10 % / -10 %) 50/60 Hz	24 V DC (+20 % / -30 %)
Power consumption		35 VA	14 W
Internal current consumption		5 V DC / max. 220 mA (from base unit), 24 V DC / 500 mA	5 V DC / max. 220 mA (from base unit), 24 V DC / 190 mA
Interface (connectors)		9-pin D-SUB for PROFIBUS/DP, 8-pin Mini-DIN for PC or programming unit FX-20P-E	
Communication speed	distance		
	1200 m	kbit/s	9.6 / 19.2 / 45.45 / 93.75
	1000 m	kbit/s	187.5
	400 m	kbit/s	500
	200 m	kbit/s	1500
	100 m	kbit/s	3000 / 6000 / 12000
Communication distance		m	Max. 1200 (depends on communication speed)
Communication cable		PROFIBUS cable with 9-pin D-SUB connector	
Max. number of controllable I/O points		256	
Weight		kg	0.4
Dimensions (W x H x D)		mm	75 x 98 x 87
Order information		Art. no.	103705 142763

The Network with Actor-Sensor Interface

Features

The AS interface is an international standard for the lowest field bus level. The network suits versatile demands, is very flexible and particularly easy to install.

Controlled are

- Sensors
- Actors
- I/O units
- Gateways

Structure

ASI networks can be configured in any random tree structure.

Up to 2 repeaters are supported providing a maximum communication distance of 300 m and 100 m without repeater. Terminating resistors are not needed.

Cable Types

A special coded 2-wire cable is required. The modules are connected to the cable via push-through connections while the coding ensures a reverse protection.

Data Exchange

The AS interface supports the connection of conventional sensors and actors following the master-slave principle.

Administration

The I/O points are assigned electronically through the bus connection or through the PLC program of the FX controller.

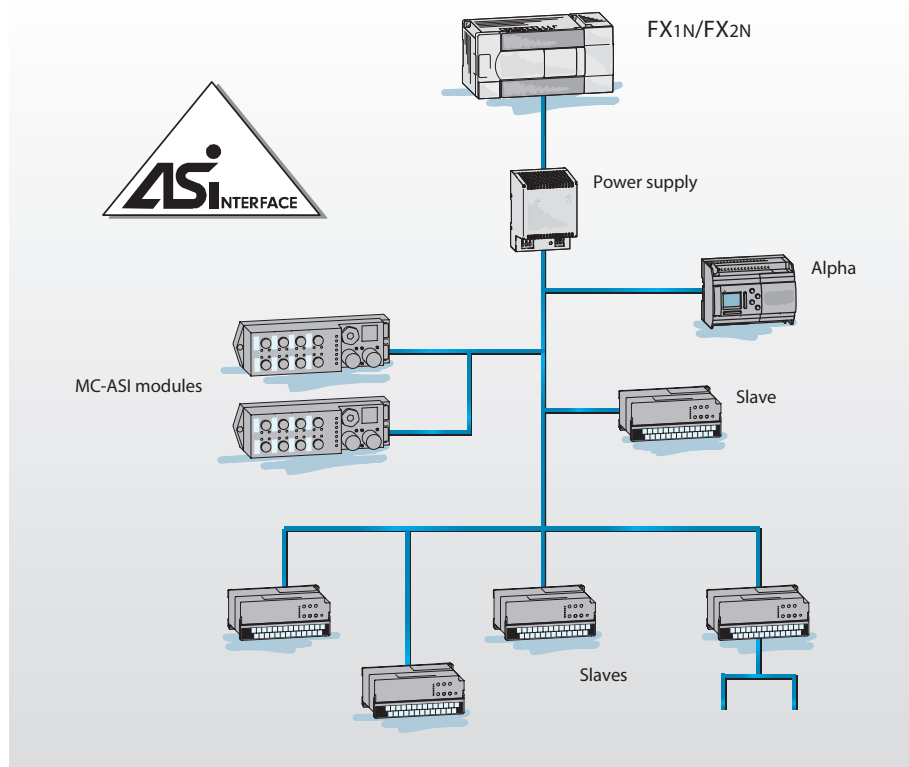

Specifications	AS interface
Network management	Master/Slave
Cabling	Coded twisted-pair cable (unshielded)
Data transfer rate	kbits/s 167
Bus cycle time	≤5 ms
Max. overall distance	m 100 (300 with repeater)
Slave units per master	31
Repeaters per network	2

BASICS



AS Interface Module FX2N-32ASI-M

☑ FX1N ☑ FX2N

BASICS

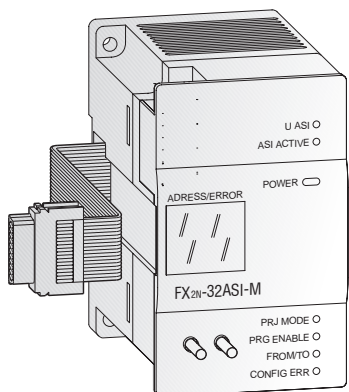

The FX2N-32ASI-M serves as master module for the connection of the FX1N and FX2N PLC to the AS-interface system. The FX2N-32ASI-M controls up to 31 slave units with up to 4 inputs and 4 outputs per I/O point. The I/O assignment in the AS interface for the slave devices is performed automatically by the master.

The maximum communication distance is 100 m without repeater. Using 2 repeaters the maximum communication distance is extended to 300 m.

The refresh time for the maximum number of 256 I/O points is 5 ms.

Specifications	FX2N-32ASI-M
Module type	Master module
General specifications	Conforms to FX1N/FX2N base units
Power supply	5 V DC / 150 mA (from base unit), 24 V DC / 70 mA external
Communication protocol	ASI standard
Communication speed	bit/s 167,000
Method	APM method (Alternating Pulse Modulation)
Communication cable	ASI standard cable
Communication distance	m 100 (300 with repeater)
Max. number of controllable units	Up to 31 slave modules (up to 4 inputs / 4 outputs per slave)
I/O refresh time	Max. 5 ms
Network setup	2 key network setup
Display	7-segment display for status and diagnosis messages
Related I/O points	8
Weight	kg 0.2
Dimensions (W x H x D)	mm 50 x 90 x 87
Order information	Art. no. 103314

MELSEC AS Interface Modules for FX2N-32ASI-M

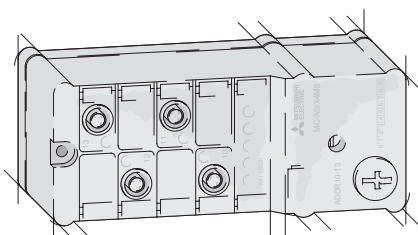

For the master module FX2N-32ASI-M a range of digital slave modules meeting the protection rating IP67 is available for M12 connector types.

AL-ASI-BD is used to integrate an ALPHA controller AL-20M□-□ into the network. The following table shows an overview of these modules.

Please refer to the Networks Technical Catalogue for further information about the AS interface and the here described modules.

Specifications	MC-ASI X8M12	MC-ASI X8M12	MC-ASI Y4M12-05	MC-ASI Y4M12-2	MC-ASI Y8M12	MC-ASI X2Y2M12	MC-ASI X4Y4M12
Type	Input module	Input module	Output module	I/O module	Output module	I/O module	I/O module
Number of I/Os	4	8	4	4	8	2 + 2	4 + 4
Order information	130257	130253	130241	130240	130238	130258	130255

Specifications	AL-ASI-BD
Type	I/O module
Number of I/Os	4
Order information	124894

The MELSEC I/O Link Network

Features

MELSEC I/O Link enables you to operate up to 64 remote inputs and 64 remote outputs.

All I/Os in the network are automatically and cyclically updated at 5.4 μ s intervals.

Up to 16 I/O modules can be connected to a master unit.

Structure

The data line's tree topology enables you to install T-junctions at any point, similar to a normal house service installation. You only need to ensure that the total coverage of the network does not exceed 200 m.

Cable Type

The network uses ordinary shielded twisted-pair cabling as the communications medium.

Administration

For the control program there is no difference at all between the remote I/Os and the local I/Os on the PLC's base units.

The station numbers of the remote I/O modules are set with simple rotary switches, making installation very easy. You also need to set the master station DIP switches for the assigned station numbers to ON.

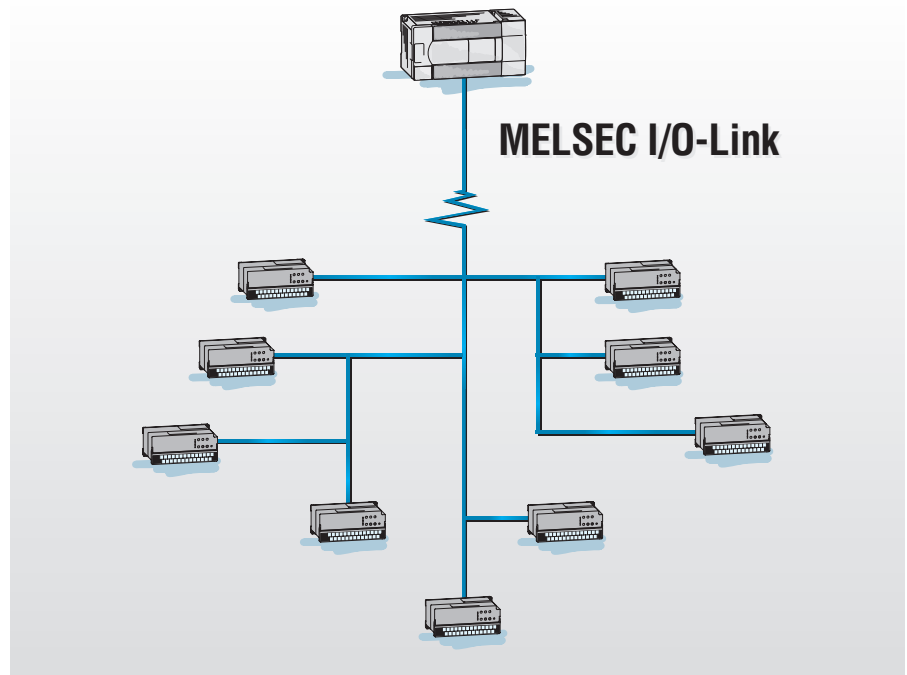

Interface	Shielded twisted-pair cabling
Cross-section	0.75 mm ² (1 pair)
Loop resistance	≤ 29 Ω / km
Electrostatic capacity	75 nF / km
Impedance (100 kHz)	110 Ω ±10 %
Insulation resistance	≥ 500 M Ω / km
Maximum distance	200 m

Important: Do not exceed the specified electrostatic capacity!



MELSEC I/O Link Master Module FX2N-16LNK-M

☑ FX1N ☑ FX2N

BASICS

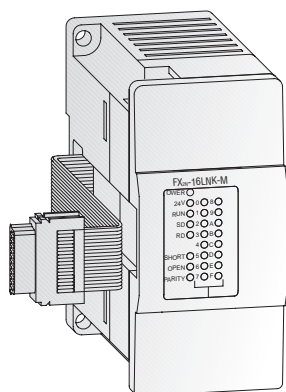

The MELSEC I/O link master module is very simple to handle. To put it into operation, all that is necessary is to set DIP switches to indicate which stations are present. Otherwise, the local I/Os behave in the same way as locally installed ones and are programmed in the same way via the PLC program.

Up to 128 inputs/output points per module can be controlled. The number of master modules is limited only by the address range of the CPU.

The cabling is made in tree structure (T connections are possible).

Specifications		FX2N-16LNK-M
Controllable I/O points		128 (using mixed modules with 4 inputs / 4 outputs)
I/O refresh time	ms	Approx. 5.4
Communication	rate	bit/s 38,400
	method	Register insertion method
	synchronization method	Combination of frame-synchronization and bit-synchronization
	error control system	Parity check
	transmission path	Bus / tree system
	transmission total distance	m 200
	I/O stations	16 (modules with 4 I/Os)
Communication cable	type	Shielded twisted-pair cable
	no. of cores	2
	diameter	≥ 0.5 mm ²
Error (RUN) display of stations		LED
No. of occupied I/O points		64 (definable by I/O assignment)
Applicable wire size	mm ²	≥ 0.75
External	voltage supply	21.6 – 27.6 V DC
	current supply (24 V DC)	mA 90
Internal power consumption (5 V DC)	mA	200
Weight	kg	0.5
Dimensions (W x H x D)	mm	43 x 90 x 87
Order information	Art. no.	86688

MELSEC I/O Link Modules for FX2N-16LNK-M

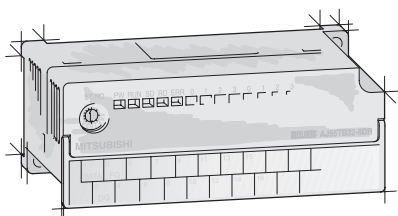

A wide range of slave modules are available for the FX2N-16LNK-M master module. The following table shows an overview of these modules.

Please refer to the Networks Technical Catalogue for further information about the MELSEC I/O Link and the here described modules.

Specifications	AJ5TB3-4D	AJ5TB3-8D	AJ5TB3-16D	AJ5TB32-4DR	AJ5TB32-8DR	AJ5TB32-16DR	AJ5TB2-4R	AJ5TB2-8R	AJ5TB2-16R
Type	Input module	Input module	Input module	I/O module	I/O module	I/O module	Output module	Output module	Output module
Number of I/Os	4	8	16	2 + 2	4 + 4	8 + 8	4	8	16
Order information	47191	47190	58548	47186	47185	58546	47189	47187	58549

The CC-Link Network

Features

The new open fieldbus and control network CC-Link provides fast data communications with different devices. The following components among others can be integrated:

- Up to 24 PLC systems
- Remote digital I/O modules
- Remote analog I/O modules
- High-speed counters
- Positioning modules
- Modules for temperature measurement
- Distributed intelligence (e.g. FX2N)
- Frequency inverters (e.g. FR-A 540)
- Operator terminals (e.g. GOT)
- Third-party devices like gateways, solenoid valves, barcode readers, etc.

Structure

The maximum bus segment extension is 1200 m (at 156 kbit/s max.). With a reduced extension, transfer rates of up to 10 Mbit/s can be achieved.

Cable Types

The data communication requires standardized shielded twisted-pair cable.

Data Exchange

Various data like digital and analog data can be exchanged easily. In addition to the cyclic transmission of word data, CC-Link systems handle transient transmission (message transmission) as well. This enables data communication with intelligent devices such as display devices, bar code readers, measuring devices, personal computers, PLC systems and digital and analog I/Os.

Administration

The programming software packages GX Developer and GX IEC Developer ensure an easy setup and commissioning.

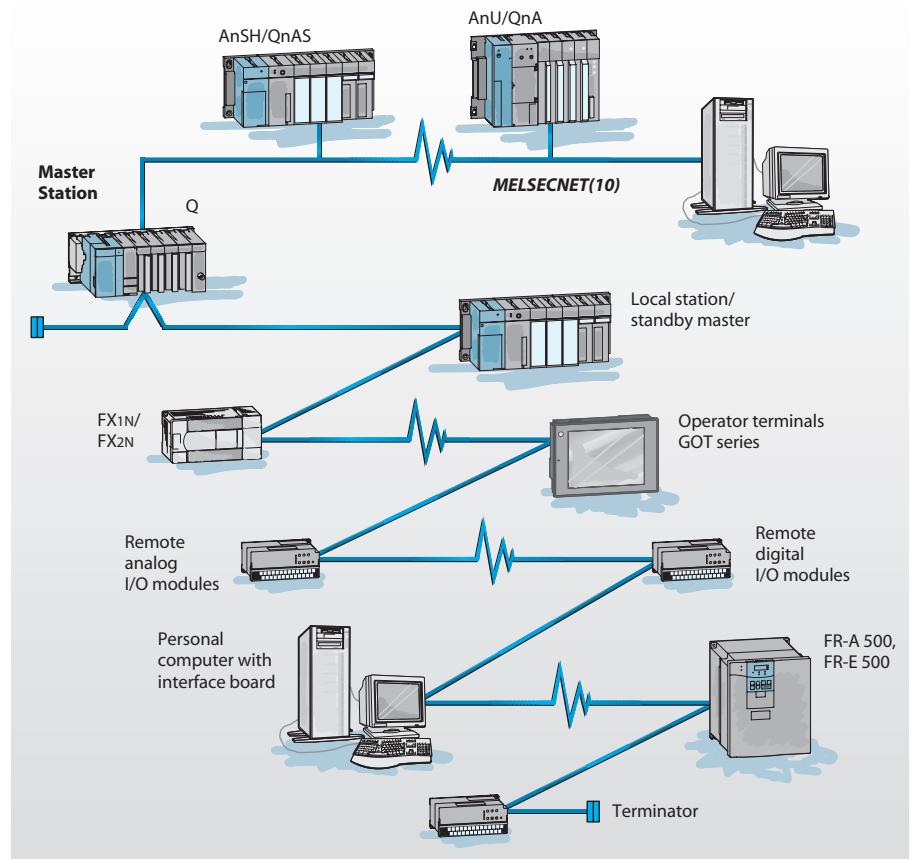

Various special features provide a particular economic network administration:

- Automatic online return function after the removal of a unit from the network
- Stand-by master function for redundancy across the system
- Automatic link cutoff function of a faulty slave station without interrupting network communications
- Link status confirmation
- Extensive test and diagnostics functions

Cable	Shielded twisted-pair
Diameter	0.5 mm ² (1 pair)
Cable resistance (20 °C)	≤37.8 Ω / km
Electrostatic capacity (1kHz)	60 nF / km
Impedance (1 MHz)	100 Ω ±15 %
Insulation resistance	≥10000 MΩ / km
Voltage withstand	500 V DC for 1 minute
Maximum distance	1200 m



■ CC-Link Master Module FX2N-16CCL-M

FX1N FX2N

BASICS

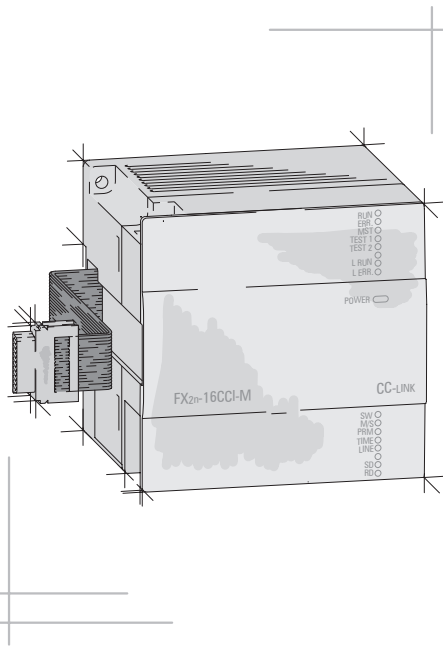

The CC-Link network enables the controlling and monitoring of decentralized I/O modules at the machine.

The CC-Link master module FX2N-16CCL-M is a special extension block which assigns an FX series PLC as the master station of the CC-Link system.

The setting of all modules within the network is handled directly via the master module.

Up to 16 remote stations and remote device stations can be connected to the master station as decentralized I/O stations. 2 master modules can be connected to one FX1N/FX2N base unit.

The maximum communications distance is 1200 m without repeater.

Specifications		FX2N-16CCL-M
Module type		Master station
Link points per station	I/O points	32
	register	8
Decentral I/O points		2,048
Number of connectable modules		Max. 16
I/O refresh time	ms	3.9 – 6.7
Synchronization method		Frame synchronization
Modulation		NRZI
Transmission route type		Shielded twisted-pair
Transmission format		HDLC
Transmission speed	Mbit/s	10 / 5 / 2.5 / 0.625 / 0.156
Communication distance	m	100 m at 10 MBit/s, 150 m at 5 MBit/s, 200 m at 2.5 MBit/s, 600 m at 0.62 MBit/s, 1200 m at 0.15 MBit/s
Transmission cable		Shielded and drilled twisted-pair cable 0.5 mm ²
Status display		5 LEDs (Power, L RUN, L ERR, SD, RD)
Power supply		5 V DC / max. 130 mA (from base unit), 24 V DC / 50 mA
Related I/O points		8
Weight	kg	0.4
Dimensions (W x H x D)	mm	85 x 90 x 87
Order information		Art. no. 133596

■ CC-Link Communication Module FX2N-32CCL

☑ FX1N ☑ FX2N

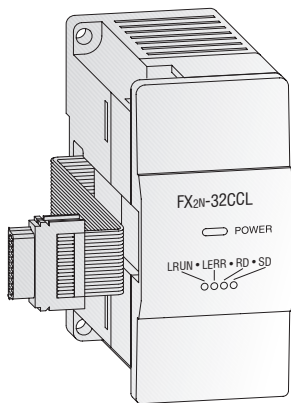

The communication module FX2N-32CCL enables the user to connect to the CC-Link network with a superior PLC system as master CPU. This gives him access to the network of all MELSEC PLC systems and frequency inverters and to additional products from other suppliers.

Thus the network is expandable via the digital inputs/outputs of the FX modules to a maximum of 512 I/Os. The buffer memory of the FX2N-32CCL is read and written by FROM/TO instructions. The connection is to the extension bus on the right side of the controller.

Specifications		FX2N-32CCL
Module type		Local station
Station numbers	no.	1 – 64 points
	stations	1 – 4
General specifications		Conforms to FX2N base units
Power supply		5 V DC / max. 130 mA (via base unit), 24 V DC / 50 mA
Communication speed	Mbit/s	10 / 5 / 2.5 / 0.625 / 0.156
Communication distance	m	100 m at 10 MBit/s, 150 m at 5 MBit/s, 200 m at 2.5 MBit/s, 600 m at 0.62 MBit/s, 1200 m at 0.15 MBit/s
Communication cable		Shielded twisted-pair 0.5 mm ²
Status display		5 LEDs (Power, L RUN, L ERR, RD, SD)
Related I/O points		8
Weight	kg	0.2
Dimensions (W x H x D)	mm	43 x 90 x 87
Order information	Art. no.	102961

■ MELSEC CC-Link Modules for FX2N-16CCL-M

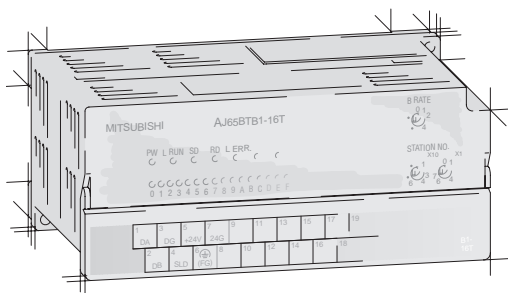

A wide range of slave modules are available for the CC-Link system. Among digital and analog remote I/O modules, different counters, positioning and interface modules are available.

The tables on the following page show an overview of these modules.

Please refer to the Networks Technical Catalogue for further information.

BASICS



Overview of the MELSEC CC-Link Modules

BASICS

Remote Inputs and Outputs

Besides three different input and output modules with up to 32 inputs, two combination module with 8 inputs and 8 outputs are available.

The remote output modules output the signals within short distance to the machine.

Specifications	AJ65BTB1-16D	AJ65BTB2-16D	AJ65BTC1-32D	AJ65BTB1-16T	AJ65BTC1-32T	AJ65BTB2-16R	AJ65BTB1-16DT	AJ65BTB2-16DR	
Module type	Input modules			Output modules			Combination module		
Inputs	16	16	32	—	—	—	8	8	
Outputs	—	—	—	16	32	16	8	8	
Output type	—	—	—	Transistor	Transistor	Relay	Transistor	Relay	
Order information	Art. no.	75447	75450	75455	75449	75456	75453	75448	75451

Analog linking to the CPU

The analog input module AJ65BT-64AD converts analog process signals into digital values that can be processed by the CPU.

Digital to analog converter modules

The modules AJ65BT-64DAV and AJ65BT-64DAI serve as remote 4-channels digital to analog converter modules with 12-bit or 13-bit binary resolution and output an analog current or voltage signal.

Temperature measuring via thermocouples

The module AJ65BT-68TD supports temperature measurements via thermocouples.

Connection of Pt100 elements

The analog modules AJ65BT-64RD3 and AJ65BT-64RD4 provide analog inputs for measuring values of Pt100 elements.

Specifications	AJ65BT-64AD	AJ65BT-64DAV	AJ65BT-64DAI	AJ65BT-64RD3	AJ65BT-64RD4	AJ65BT-68TD	
Input points	4	4	4	4	4	8	
Input type	Analog	Digital	Digital	Pt100 (3-wire type)	Pt100 (4-wire type)	Thermocouple	
Order information	Art. no.	75444	75446	75445	88026	88027	88025

Automatic hardware counter

The high-speed counter modules AJ65BT-D62 and AJ65BT-62D / 62D-S1 acquire signals at a frequency which conventional input modules cannot acquire. Positioning tasks or frequency measurements for example can be performed.

Positioning with an open control loop

The module AJ65BT-D75P2-S3 generates the go command via a pulse chain. The velocity is proportional to the pulse frequency. The travel is proportional to the pulse length.

Data exchange with peripherals

The module AJ65BT-R2 serves for the communication with peripheral devices through a standard RS232 interface. The module AJ65BT-G4-S3 serves for the communication with peripheral devices through a standard RS422 interface. The peripherals are connected point to point (1:1).

Specifications	AJ65BT-D62	AJ65BT-62D / 62D-S1	AJ65BT-D75P2-S3	AJ65BT-G4-S3	AJ65BT-R2	
Module type	High-speed counter	High-speed counter	Positioning module	RS422 interface module	RS232 interface module	
Function	2 counters (1 or 2 phases)	2 counters (1 or 2 phases)	2 control axes	1 x RS422 (25 pole)	1 x RS232 (D-Sub, 9 pole)	
Order information	Art. no.	88028	88029 / 88030	88002	134389	88003

All listed modules are also available in compact design with even smaller dimensions. Please refer to the Networks Catalogue for further details.

The DeviceNet Network

Features

The DeviceNet represents a cost-effective solution for the network integration of low-level terminal equipment. Up to 64 devices including a master can be integrated in one network.

Structure

Due to the supported tree structure of the data line, a T-junction can be installed in any place. It has to be considered that the overall extension must not exceed 500 m.

Using repeaters increases the overall extension to 3 km.

Cable Types

For the data exchange a cable with two shielded twisted-pair cables is used.

Parameterization

Parameterization is done with the configuration software SyCon from Ver. 2.0.6.2 by the Hilscher company.

Communications

The bus accessing method CSMA/NDA ensures an extremely fast and efficient access of the link devices to the bus.

Based on the Producer/Consumer network model this method ensures greater determinism of all data.

The slave modules communicate via the following methods:

- Polling
- Bit strobe
- Change of state
- Cyclic

Information at a size of 8 bytes per data packet can be transmitted. Packets exceeding these 8 bytes are fragmented automatically.

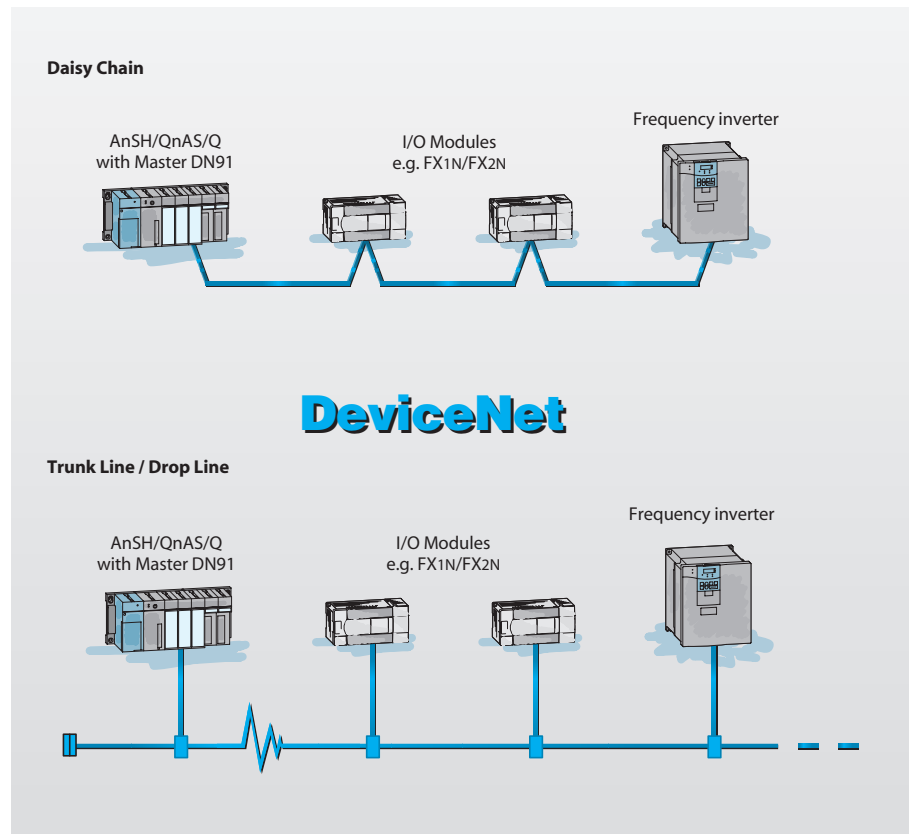

Cabel		Thick Cable	Thin Cable
Outline diameter	mm	12,2	6,9
Inside wire for data (blue / white)		18AWG19x30 zinc plated	24AWG19x36 zinc plated
Inside wire for power supply (red / black)		15AWG19x28 zinc plated	22AWG19x34 zinc plated
Trunkline		Yes	Yes
Dropline		Yes	Yes
Max. distance	m	500	500
Max. distance incl. repeater	m	3000	3000



■ DeviceNet Slave Module FX2N-64DNET

☑ FX1N ☑ FX2N

BASICS

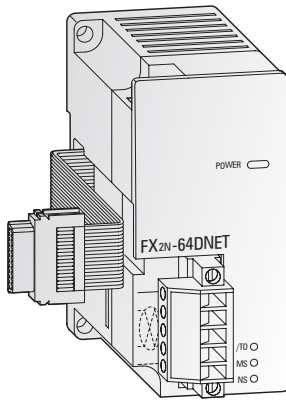

The DeviceNet slave module FX2N-64DNET can be used to connect FX1N and FX2N programmable controller to a DeviceNet network. The FX2N-64DNET is a slave (group 2) on DeviceNet.

The FX2N-64DNET can communicate to the master by the master/slave communication (using the master/slave I/O connection), and to other nodes supporting the UCMM connection by client/server communication (using the UCMM connection).

The communication method for I/O connection supports “polling”, “cyclic” and “change of state”.

The communication between the programmable controller and the internal buffer memory of the FX2N-64DNET is handled by FROM/ TO instructions.

Specifications			FX2N-64DNET
Node type			G2 Server
Station numbers			0 – 63 points
Supported communication speeds		kBaud	125, 250, 500
Communication cable			DeviceNet standard (see table on previous page)
Communication data (open connection)	Master/slave	no. of connections	1 connection (group 2)
		transfer time-out	2,000 ms (ACK time-out)
UCMM client/server		no. of connections	63/63 (group 1, 3)
		data length	Max. 64 byte per connection
Communication data (I/O connection)		type	Polling, cyclic, change of state
		data length	Max. 64 bytes (fragmentation is possible)
Module ID code			K 7090
Status displays			Power, module status, network status
Related I/O points			8
External	power supply	V DC	24
	current consumption	mA	50
Internal power consumption (5 V DC)			120
Weight			kg 0,2
Dimensions (W x H x D)			mm 43 x 90 x 87
Order information			Art. no. 131708

MELSEC Peer-to-Peer Network, Multidrop Network, Parallel Link

The networks in details:

● Peer-to-Peer Network

You can integrate up to 8 programmable logic controllers in a peer-to-peer network. All stations in the network can monitor all the devices in the entire data range. However, data writing, setting and resetting of individual devices is always only performed in the specific station in question.

Each network station can transfer packets of up to 64 bits and 8 data words via the network.

The maximum distance between the first and last connected stations depends on the type of adapters used:

- FX0N-485ADP: max. 500 m (CPU vers. 2.0)
- FX1N-485BD: max. 50 m
- FX2N-485BD: max. 50 m

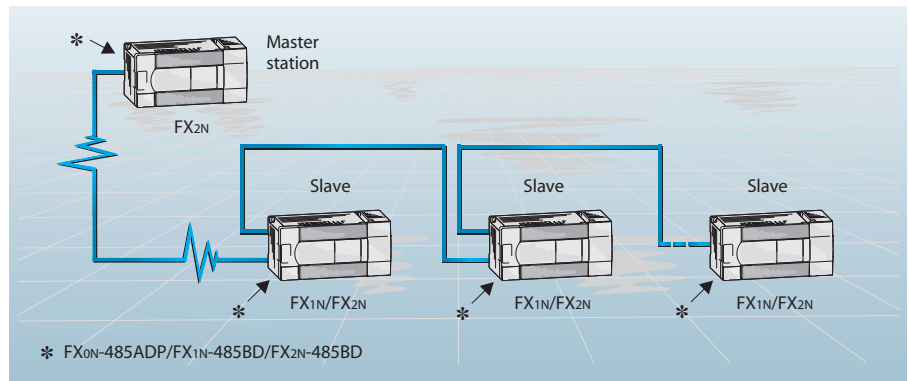

● 1 : n Multidrop Network

This network is used for displaying and monitoring data from the individual stations on a connected computer.

You can connect up to 16 stations in one of these networks. The maximum distance between the first and last connected station depends on the type of adapters used:

- FX0N-485ADP: max. 500 m
- FX1N-485BD: max. 50 m
- FX2N-485BD: max. 50 m

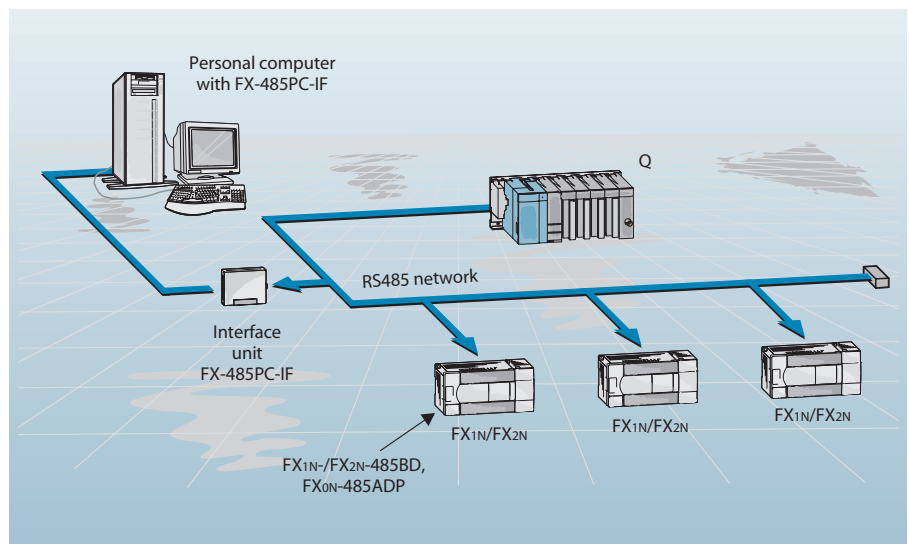

● Parallel Link

As the name indicates, parallel link mode connects two programmable logic controllers with a parallel link. Data communication between the two stations is performed automatically via a predefined range of relays and data registers.

The maximum distance between two stations connected by parallel link is 50 m.

If the FX0N-485ADP is used, the maximum distance will be 500 m.

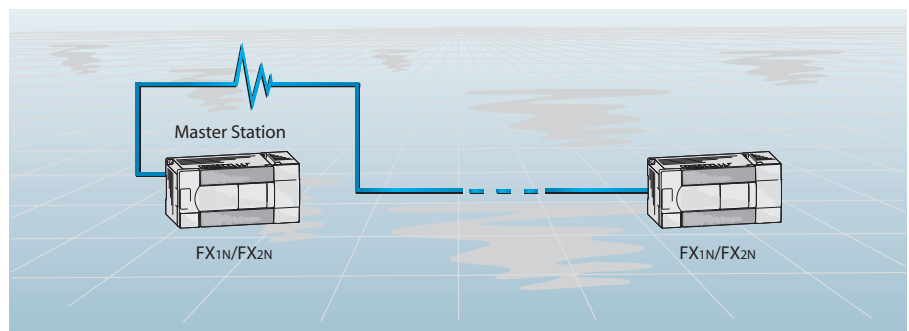

Interface Adapters FX1N-485BD and FX2N-485BD

☑ FX1N ☑ FX2N

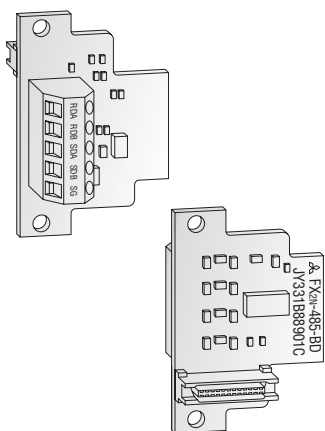

The interface adapters FX□N-485BD provide the FX1N/FX2N with an additional RS485 interface. The adapter, which is simply inserted into the base unit's expansion slot, enables the configuration of RS485 1:n multidrop, parallel link or peer-to-peer networks with FX1N/FX2N systems.

You can also transfer data directly to other RS485 peripherals using the RS dedicated instruction.

In peer-to-peer network configurations the interface adapter enables active communication between the individual FX1N/FX2N controllers via the RS485 interfaces.

In 1:n multidrop networks the adapter can be used to provide communication with a host master station of the A series.

Specifications	FX1N-485BD	FX2N-485BD
Applicable for	FX1S/FX1N base units	FX2N base units
General specifications	Conforms to FX1S/FX1N/FX2N base units	
Power supply	5 V DC / 60 mA from base unit	
Interface	RS485 / RS422	
Communication speed	bit/s	300 – 19,200
Communication cable	Twisted-pair	
Communication distance	m	Max. 50
Protocols	Protocol 1 or 4 of AJ71UC24 / no protocol / parallel link / peer-to-peer network	
Related I/O points	Station	0
Weight	kg	0.02
Dimensions (W x H x D)	mm	43 x 38,5 x 22
Order information	Art. no.	130742
		65597

Communication Module FX0N-485ADP

☑ FX1N ☑ FX2N

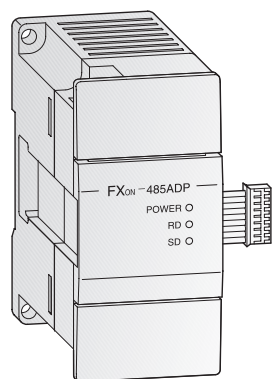

The communication module FX0N-485ADP enables the configuration of 1:n multidrop, parallel link or peer-to-peer networks using the RS485 interface.

The communication module is connected directly to the communication bus on the left-hand side of the FX1N base unit. The FX1N-CNV-BD (FX2N-CNV-BD) communication adapter is required for connection to FX1N (FX2N) base unit.

Specifications	FX0N-485ADP	
General specifications	Conforms to FX1S/FX1N/FX2N base units	
Power supply	5 V DC / max. 30 mA (from base unit), 24 V DC / 50 mA	
Interface	RS485	
Communication speed	Bit/s	300 – 19200
Communication distance	m	Max. 500
Communication cable	Shielded cable	
Communication mode	Half duplex	
Protocols	Protocol 1 and 4 of AJ71UC24	
Related I/O points	—	
Weight	kg	0.3
Dimensions (W x H x D)	mm	43 x 90 x 87
Order information	Art. no.	66665

Interface Unit for RS485 1:n Multidrop Network FX-485PC-IF

☑ FX1N ☑ FX2N

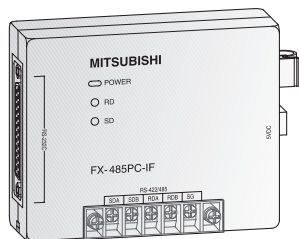

The interface unit FX-485PC-IF is used for converting interface signals.

The interface unit has an RS232C interface for connection to a PC and RS485 ports for connection to the 1:n multidrop network.

Specifications		FX-485PC-IF
General specifications		Conforms to FX1N/FX2N base units
Current consumption	mA	260
Power supply		5 V DC ±5 %
Interface		RS232C / RS485
Communication speed	bit/s	300, 600, 1200, 2400, 4800, 9600, 19200
Communication cable		Shielded cable
Communication distance	m	15 (RS232C) 500 (RS485)
Communication mode		Half duplex
Protocols		Protocol 1 and 4 of AJ171UC24
Weight	kg	0.3
Dimensions (W x H x D)	mm	100 x 80 x 30
Order information	Art. no.	53416

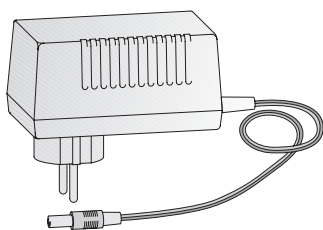

The power supply is used for the interface unit FX-485PC-IF.

Specifications		SC06 N-PG
General specifications		Conforms to FX-485PC-IF
Power supply		5 V DC / 800 mA
Weight	kg	0.2
Dimensions (W x H x D)	mm	60 x 100 x 100
Order information	Art. no.	32630

Interface Converter CR01-R2/R4 SET and CR01-R4/R4

☑ FX1N ☑ FX2N

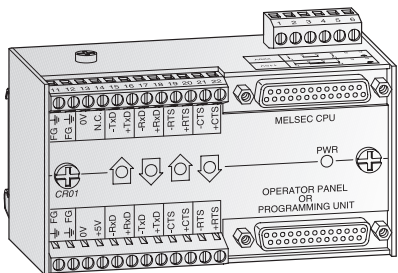

The interface converter CR01-R2/R4 SET and CR01-R4/R4 are signal amplifiers with photocoupler isolation for RS422 signals. They are used to connect a PLC with external devices like operation panels or a personal computer, especially when a poten-

tial isolation is required and when the wiring length takes more than 15 meters. If one module is connected to a PLC and another one to an operator panel or a personal computer, a max. distance of 1200 m is possible.

Specifications	CR01-R2/R4 SET	CR01-R4/R4
Interface converting	RS422 ↔ RS232	RS422 ↔ RS422
Order information	Art. no. 56172	56173

BASICS



■ Communication Adapter FX2N-CNV-IF

☑ FX1N ☑ FX2N

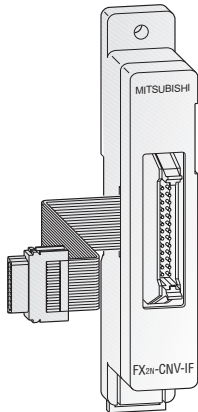

The communication adapter FX2N-CNV-IF enables you to connect your FX series special function modules to FX1N/FX2N systems.

The communication adapter provides compatibility between the FX1N/FX2N CPU and the digital FX modules and special function modules.

Specifications	FX2N-CNV-IF	
General specifications	Conforms to FX1N/FX2N base units	
Power supply	Not necessary	
Related I/O points	0	
Weight	kg	0.15
Dimensions (W x H x D)	mm	23 x 140 x 45
Order information	Art. no.	65599

■ Communication Adapters FX1N-CNV-BD and FX2N-CNV-BD

☑ FX1N ☑ FX2N

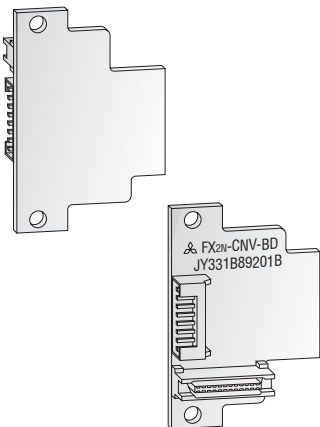

The communication adapters FX□N-CNV-BD enable connection of the FX0N-232ADP and FX0N-485ADP special function modules

to the left-hand side of the FX1N and FX2N base units.

Specifications	FX1N-CNV-BD	FX2N-CNV-BD
Applicable for	Base units FX1S/FX1N	Base units FX2N
General specifications	Conforms to FX1N/FX2N base units	
Power supply	Not necessary	
Related I/O points	0	0
Weight	kg	0.08
Dimensions (W x H)	mm	43 x 38 x (D) 14
Order information	Art. no.	130745
		65598

■ PROM Adapter FX-ROM SOC1

☑ FX1N ☑ FX2N

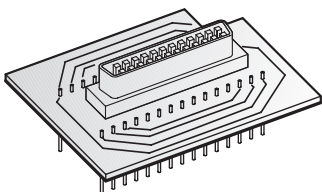

The PROM adapter FX-ROM SOC1 is used for adapting memory cassettes to a textool base.

This socket is required if the memory cassette FX-EPROM-8 is to be written with a commercial EPROM loader in order, for example, to load a MELSOFT program.

Specifications	FX-ROM SOC1	
Order information	Art. no.	27163

Memory Cassettes

FX1N FX2N

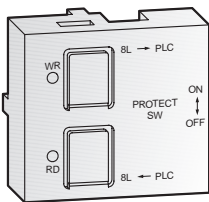
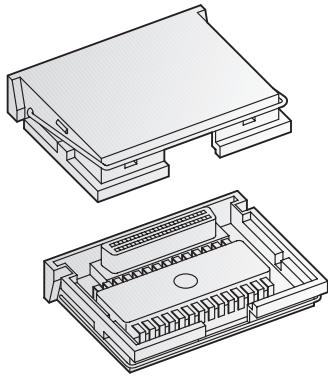

All FX1S, FX1N and FX2N base units are equipped with a slot for the optional, robust FX memory cassettes.

By connection of these memory cassettes, the internal memory of the controller is switched off and only the program specified in the respective memory cassette is run.

The memory size can be extended for all FX2N controllers up to 16.000 steps with the memory cassette FX-RAM-8.

The FX1N-EEPROM-8L is a program memory, which is a writing/reading unit for data transfer at the same time.

The FX2N-ROM-E1 memory module simplifies the direct communication between the FX2N and the Mitsubishi Electric frequency inverters of the series FR-S500, FR-E500, and FR-A500.

The FX2N-ROM-E1 technically corresponds to the FX-EEPROM-16.

Specifications	FX-RAM-8	FX-EPROM-8	FX-EEPROM-4
Memory type	RAM	EPROM	EEPROM
Size	16,000 steps (FX2N)	8,000 steps	4,000 steps
Applicable for CPU type	FX2N	FX2N	FX2N
Order information	Art. no. 23823	23824	23825

Specifications	FX-EEPROM-8	FX1N-EEPROM-8L	FX-EEPROM-16	FX2N-ROM-E1
Memory type	EEPROM	EEPROM	EEPROM	EEPROM
Size	8000 steps	2000/8000 steps	16000 steps	16000 steps
Applicable for CPU type	FX2N	FX1S/FX1N	FX2N	FX2N
Order information	Art. no. 23826	130746	65600	141528

Batteries F2-40BL and FX2NC-32BL

FX1N FX2N

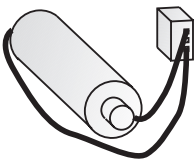

The battery F2-40BL can be used for all base units of the MELSEC FX2N series. The battery FX2NC-32BL is only suitable for the modules FX2N-10/20GM.

The battery buffers the internal RAM of the MELSEC FX2N PLC in the event of a voltage failure.

Specifications	F2-40BL	FX2NC-32BL
Application	FX2N base units	FX2N-20GM
Order information	Art. no. 5142	128725

BASICS



■ Display Module FX1N-5DM

FX1N FX2N

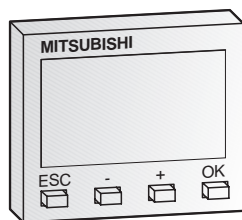

The display module FX1N-5DM is inserted directly into the controller and enables monitoring and editing of the data stored in the PLC.

The display module e.g. can be used instead of digital switches and external 7-segment displays in very confined areas.

The following detailed functions can be performed by the FX1N-5DM:

- Bit and word device monitoring (X, Y, M, S and T, C, D)
- Current and set values can be altered during monitoring (T, C and D)
- Devices can be forced on and off (Y, M and S)
- Current time of the real-time clock can be displayed and set
- Error code display

Specifications	FX1N-5DM
General specifications	Conforms to FX1N base units
Power supply	5 V DC ±5 % (from base unit)
Current consumption	mA 110
Display	LCD (with backlight)
Weight	kg 0.02
Dimensions (W x H x D)	mm 40 x 32 x 11
Order information	Art. no. 129197

■ Control and Display Panel FX-10DM-E

FX1N FX2N

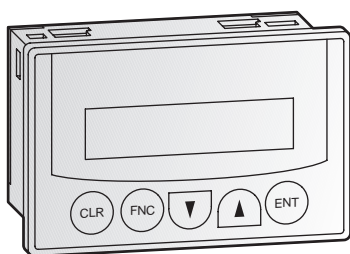

The control and display panel FX-10-DM-E provides a key-oriented user-interface and enables you to monitor and edit process data in the PLC.

The display is arranged in 2 rows for 16 characters each. Functions can be invoked and values can be edited via keys.

The connection to the PLC is set up by the FX-20P-CAB0 cable.

The following detailed functions can be performed by the FX-10-DM-E:

- Word device monitoring
- Comments or message can be attached to up to 8 devices
- Message display (ASCII code) from data registers
- Current and set values can be altered for the displayed device
- Current time of the real-time clock can be displayed and set

Specifications	FX-10DM-E
General specifications	Conforms to FX1N/FX2N base units
Application	All FX1S/FX1N/FX2N base units
Power supply	5 V DC ±5 % (from base unit)
Current consumption	mA 220
Display	LCD (with backlight)
Resolution	2 x 16 signs (80 x 16 pixels)
Weight	kg 0,02
Dimensions (W x H x D)	mm 86 x 73 x 32
Order information	Art.-Nr. 132600

Please refer to the HMI Technical Catalogue for further control panels.

■ Simulation Strip Input-SIM

☑ FX1N ☑ FX2N

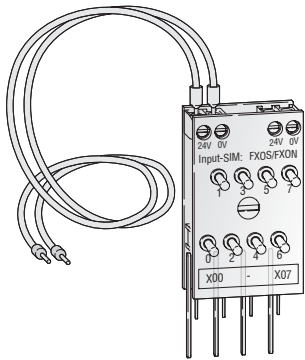

The simulation strip Input-SIM has 8 switches for simulating digital inputs. The simulation strip is directly mounted to the terminals of the base unit and fixed with screws to the terminal block. A cable is provided for connecting the simulation strip to the power supply.

Two different simulation strips are available due to the differences within the terminal block between the MELSEC FX1N and FX2N series PLCs. The simulation strip can be expanded with another strip for further inputs.

Specifications	Input-SIM: FX0S/FX0N	Input-SIM: FX2N
Switches	8	8
Application	FX1S and FX1N series	FX2N series
Dimensions (W x H x D) mm	30 x 50 x 15	30 x 50 x 15
Order information	Art. no. 65081	66513

■ Simulation Box

☑ FX1N ☑ FX2N

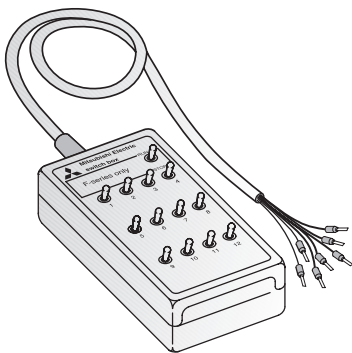

The simulation box has 12 switches for simulating digital inputs. It can be used on all controllers of the MELSEC FX family.

Specifications	Simulation Box
Switches	12
Order information	Art. no. 3386

■ Connection Cable for Modular and Compact Extension Units

☑ FX1N ☑ FX2N

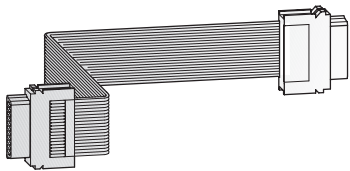

The FX0N-65EC cable is used for connection between a modular unit or and a compact extension unit. This permits a multi-row arrangement of a MELSEC FX1N/FX2N system. The cable must be connected to the left side of the compact extension unit.

The FX2N-CNV-BC cable is used for connection between a special function module and a modular extension unit in combination with the FX0N-65EC.

Specifications	FX0N-65EC	FX2N-CNV-BC
Type	Flat cable	Flat cable connector
Length / Dimensions m	0.65	W 60 x H 40 x D 16
Order information	Art. no. 45348	70880

BASICS



Base Units MELSEC FX1N

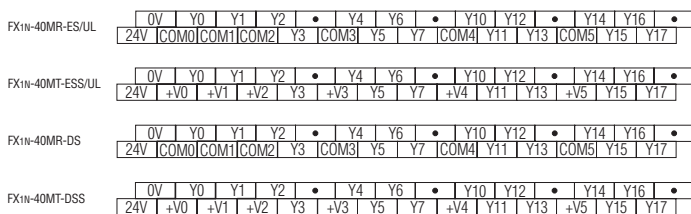
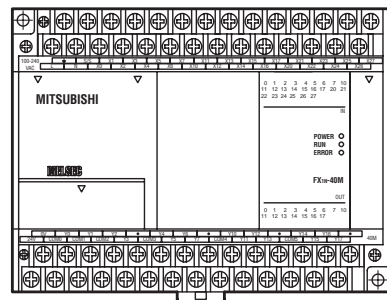
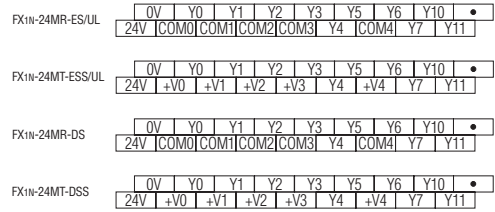
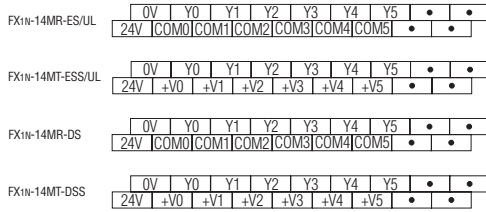
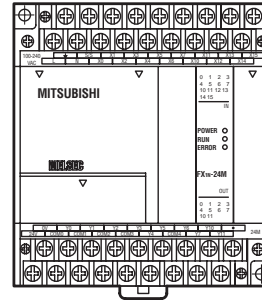
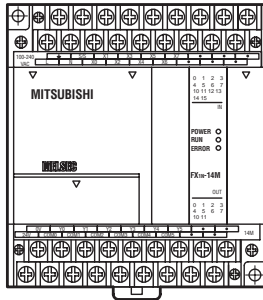
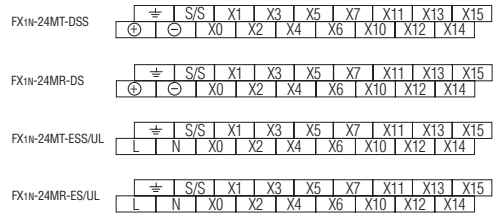
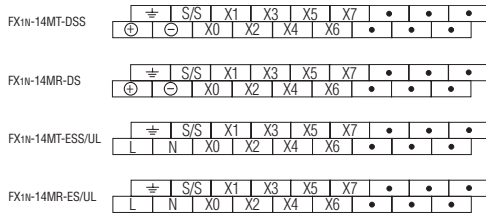

FX1N-60MT-DSS	⊕	S/S	X1	X3	X5	X7	X11	X13	X15	X17	X21	X23	X25	X27	X31	X33	X35	X37	X41	X43
	⊖		X0	X2	X4	X6	X10	X12	X14	X16	X20	X22	X24	X26	X30	X32	X34	X36	X40	X42
FX1N-60MR-DS	⊕	S/S	X1	X3	X5	X7	X11	X13	X15	X17	X21	X23	X25	X27	X31	X33	X35	X37	X41	X43
	⊖		X0	X2	X4	X6	X10	X12	X14	X16	X20	X22	X24	X26	X30	X32	X34	X36	X40	X42
FX1N-60MT-ESS/UL	⊕	S/S	X1	X3	X5	X7	X11	X13	X15	X17	X21	X23	X25	X27	X31	X33	X35	X37	X41	X43
	L	N	X0	X2	X4	X6	X10	X12	X14	X16	X20	X22	X24	X26	X30	X32	X34	X36	X40	X42
FX1N-60MR-ES/UL	⊕	S/S	X1	X3	X5	X7	X11	X13	X15	X17	X21	X23	X25	X27	X31	X33	X35	X37	X41	X43
	L	N	X0	X2	X4	X6	X10	X12	X14	X16	X20	X22	X24	X26	X30	X32	X34	X36	X40	X42

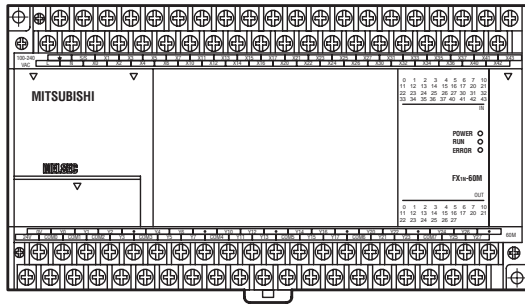

FX1N-60MR-ES/UL	0V	Y0	Y1	Y2	•	Y4	Y6	•	Y10	Y12	•	Y14	Y16	•	Y20	Y22	•	Y24	Y26	•
	24V	COM0	COM1	COM2	Y3	COM3	Y5	Y7	COM4	Y11	Y13	COM5	Y15	Y17	COM6	Y21	Y23	COM7	Y25	Y27
FX1N-60MT-ESS/UL	0V	Y0	Y1	Y2	•	Y4	Y6	•	Y10	Y12	•	Y14	Y16	•	Y20	Y22	•	Y24	Y26	•
	24V	+V0	+V1	+V2	Y3	+V3	Y5	Y7	+V4	Y11	Y13	+V5	Y15	Y17	+V6	Y21	Y23	+V7	Y25	Y27
FX1N-60MR-DS	0V	Y0	Y1	Y2	•	Y4	Y6	•	Y10	Y12	•	Y14	Y16	•	Y20	Y22	•	Y24	Y26	•
	24V	COM0	COM1	COM2	Y3	COM3	Y5	Y7	COM4	Y11	Y13	COM5	Y15	Y17	COM6	Y21	Y23	COM7	Y25	Y27
FX1N-60MT-DSS	0V	Y0	Y1	Y2	•	Y4	Y6	•	Y10	Y12	•	Y14	Y16	•	Y20	Y22	•	Y24	Y26	•
	24V	+V0	+V1	+V2	Y3	+V3	Y5	Y7	+V4	Y11	Y13	+V5	Y15	Y17	+V6	Y21	Y23	+V7	Y25	Y27

BASICS



Base Units MELSEC FX2N

BASICS

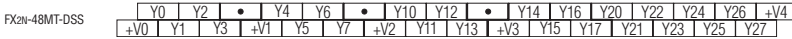
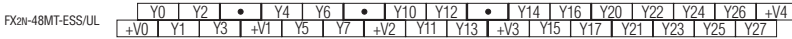
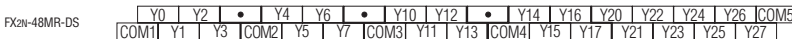
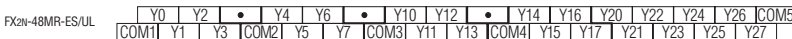
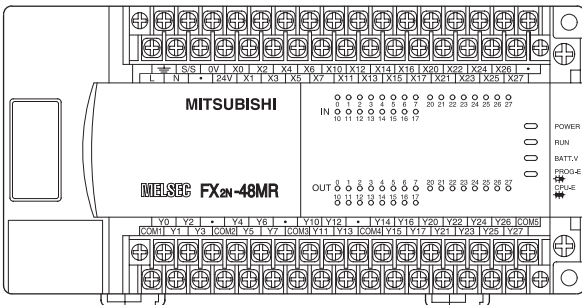
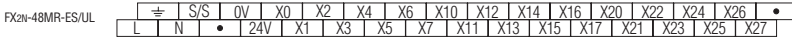
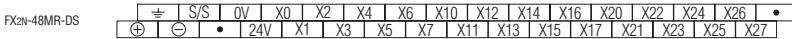
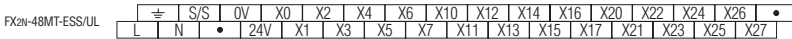
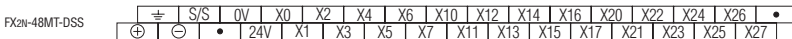
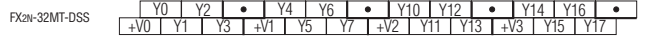
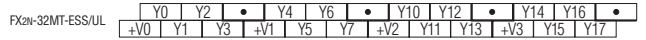
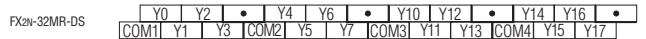
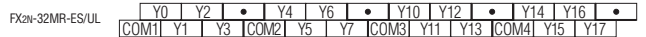
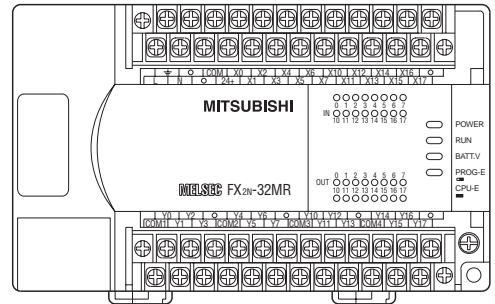
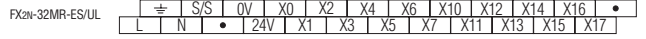
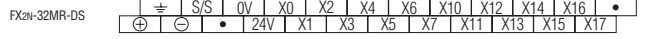
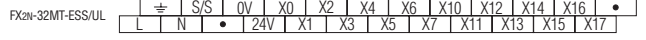
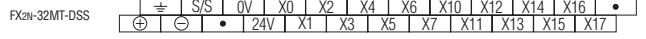
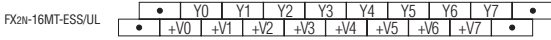
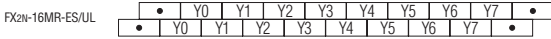
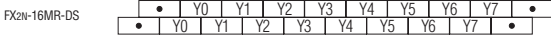
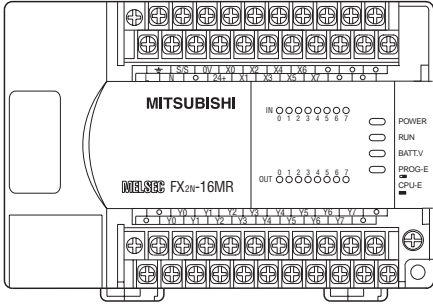
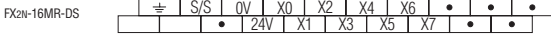
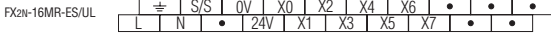
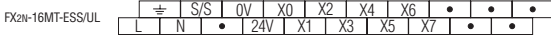

FX2N-64MT-DSS	⊕ S/S 0V 0V X0 X2 X4 X6 X10 X12 X14 X16 X20 X22 X24 X26 X30 X32 X34 X36 • ⊖ • 24V 24V X1 X3 X5 X7 X11 X13 X15 X17 X21 X23 X25 X27 X31 X33 X35 X37
FX2N-64MT-ESS/UL	⊕ S/S 0V 0V X0 X2 X4 X6 X10 X12 X14 X16 X20 X22 X24 X26 X30 X32 X34 X36 • L N • 24V 24V X1 X3 X5 X7 X11 X13 X15 X17 X21 X23 X25 X27 X31 X33 X35 X37
FX2N-64MR-DS	⊕ S/S 0V 0V X0 X2 X4 X6 X10 X12 X14 X16 X20 X22 X24 X26 X30 X32 X34 X36 • ⊕ ⊖ • 24V 24V X1 X3 X5 X7 X11 X13 X15 X17 X21 X23 X25 X27 X31 X33 X35 X37
FX2N-64MR-ES/UL	⊕ S/S 0V 0V X0 X2 X4 X6 X10 X12 X14 X16 X20 X22 X24 X26 X30 X32 X34 X36 • L N • 24V 24V X1 X3 X5 X7 X11 X13 X15 X17 X21 X23 X25 X27 X31 X33 X35 X37

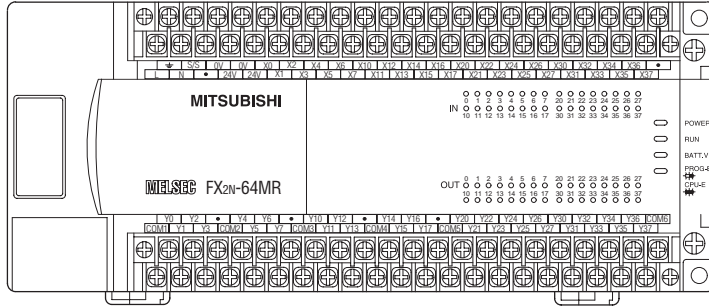

FX2N-64MR-ES/UL	Y0 Y2 • Y4 Y6 • Y10 Y12 • Y14 Y16 • Y20 Y22 Y24 Y26 Y30 Y32 Y34 Y36 COM6 COM1 Y1 Y3 COM2 Y5 Y7 COM3 Y11 Y13 COM4 Y15 Y17 COM5 Y21 Y23 Y25 Y27 Y31 Y33 Y35 Y37
FX2N-64MR-DS	Y0 Y2 • Y4 Y6 • Y10 Y12 • Y14 Y16 • Y20 Y22 Y24 Y26 Y30 Y32 Y34 Y36 COM6 COM1 Y1 Y3 COM2 Y5 Y7 COM3 Y11 Y13 COM4 Y15 Y17 COM5 Y21 Y23 Y25 Y27 Y31 Y33 Y35 Y37
FX2N-64MT-ESS/UL	Y0 Y2 • Y4 Y6 • Y10 Y12 • Y14 Y16 • Y20 Y22 Y24 Y26 Y30 Y32 Y34 Y36 +V5 +V0 Y1 Y3 +V1 Y5 Y7 +V2 Y11 Y13 +V3 Y15 Y17 +V4 Y21 Y23 Y25 Y27 Y31 Y33 Y35 Y37
FX2N-64MT-DSS	Y0 Y2 • Y4 Y6 • Y10 Y12 • Y14 Y16 • Y20 Y22 Y24 Y26 Y30 Y32 Y34 Y36 +V5 +V0 Y1 Y3 +V1 Y5 Y7 +V2 Y11 Y13 +V3 Y15 Y17 +V4 Y21 Y23 Y25 Y27 Y31 Y33 Y35 Y37

FX2N-80MT-DSS	⊕ S/S 0V 0V X0 X2 X4 X6 X10 X12 X14 X16 • X20 X22 X24 X26 • X30 X32 X34 X36 • X40 X42 X44 X46 • ⊖ • 24V 24V X1 X3 X5 X7 X11 X13 X15 X17 • X21 X23 X25 X27 • X31 X33 X35 X37 • X41 X43 X45 X47
FX2N-80MT-ESS/UL	⊕ S/S 0V 0V X0 X2 X4 X6 X10 X12 X14 X16 • X20 X22 X24 X26 • X30 X32 X34 X36 • X40 X42 X44 X46 • L N • 24V 24V X1 X3 X5 X7 X11 X13 X15 X17 • X21 X23 X25 X27 • X31 X33 X35 X37 • X41 X43 X45 X47
FX2N-80MR-DS	⊕ S/S 0V 0V X0 X2 X4 X6 X10 X12 X14 X16 • X20 X22 X24 X26 • X30 X32 X34 X36 • X40 X42 X44 X46 • ⊕ ⊖ • 24V 24V X1 X3 X5 X7 X11 X13 X15 X17 • X21 X23 X25 X27 • X31 X33 X35 X37 • X41 X43 X45 X47
FX2N-80MR-ES/UL	⊕ S/S 0V 0V X0 X2 X4 X6 X10 X12 X14 X16 • X20 X22 X24 X26 • X30 X32 X34 X36 • X40 X42 X44 X46 • L N • 24V 24V X1 X3 X5 X7 X11 X13 X15 X17 • X21 X23 X25 X27 • X31 X33 X35 X37 • X41 X43 X45 X47

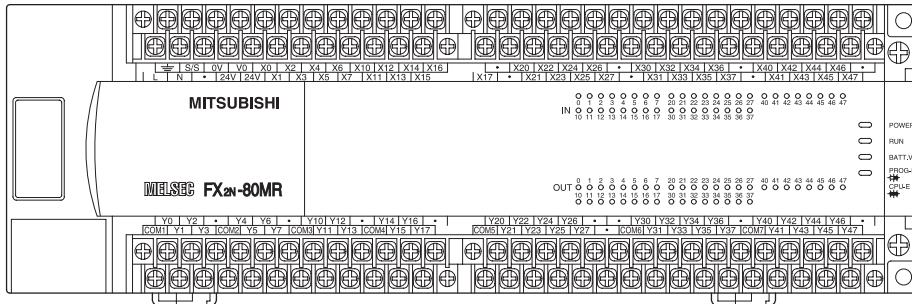

FX2N-80MR-ES/UL	Y0 Y2 • Y4 Y6 • Y10 Y12 • Y14 Y16 • Y20 Y22 Y24 Y26 • Y30 Y32 Y34 Y36 • Y40 Y42 Y44 Y46 • COM1 Y1 Y3 COM2 Y5 Y7 COM3 Y11 Y13 COM4 Y15 Y17 COM5 Y21 Y23 Y25 Y27 • COM6 Y31 Y33 Y35 Y37 COM7 Y41 Y43 Y45 Y47
FX2N-80MR-DS	Y0 Y2 • Y4 Y6 • Y10 Y12 • Y14 Y16 • Y20 Y22 Y24 Y26 • Y30 Y32 Y34 Y36 • Y40 Y42 Y44 Y46 • COM1 Y1 Y3 COM2 Y5 Y7 COM3 Y11 Y13 COM4 Y15 Y17 COM5 Y21 Y23 Y25 Y27 • COM6 Y31 Y33 Y35 Y37 COM7 Y41 Y43 Y45 Y47
FX2N-80MT-ESS/UL	Y0 Y2 • Y4 Y6 • Y10 Y12 • Y14 Y16 • Y20 Y22 Y24 Y26 • Y30 Y32 Y34 Y36 • Y40 Y42 Y44 Y46 • +V0 Y1 Y3 +V1 Y5 Y7 +V2 Y11 Y13 +V3 Y15 Y17 +V4 Y21 Y23 Y25 Y27 • +V5 Y31 Y33 Y35 Y37 +V6 Y41 Y43 Y45 Y47
FX2N-80MT-DSS	Y0 Y2 • Y4 Y6 • Y10 Y12 • Y14 Y16 • Y20 Y22 Y24 Y26 • Y30 Y32 Y34 Y36 • Y40 Y42 Y44 Y46 • +V0 Y1 Y3 +V1 Y5 Y7 +V2 Y11 Y13 +V3 Y15 Y17 +V4 Y21 Y23 Y25 Y27 • +V5 Y31 Y33 Y35 Y37 +V6 Y41 Y43 Y45 Y47

BASICS



■ Compact Extension Units MELSEC FX0N

FX0N-40ET-DSS	⊕ S/S S/S X1 X3 X5 X7 X1 X3 X5 X7 X1 X3 X5 X7
	⊖ X0 X2 X4 X6 X0 X2 X4 X6 X0 X2 X4 X6
FX0N-40ER-DS	⊕ COM COM X1 X3 X5 X7 X1 X3 X5 X7 X1 X3 X5 X7
	⊖ X0 X2 X4 X6 X0 X2 X4 X6 X0 X2 X4 X6
FX0N-40ER-ES/UL	⊕ COM COM X1 X3 X5 X7 X1 X3 X5 X7 X1 X3 X5 X7
	L N X0 X2 X4 X6 X0 X2 X4 X6 X0 X2 X4 X6

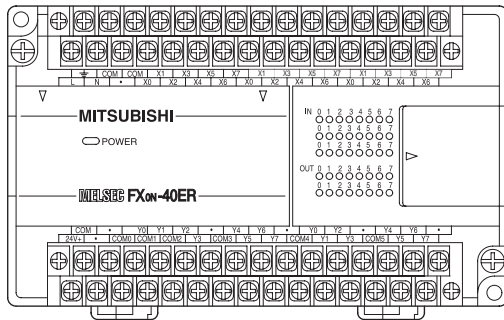

FX0N-40ER-ES/UL	COM X0 X2 X4 X6 X0 X2 X4 X6 X0 X2 X4 X6
	24V COM0 COM1 COM2 Y3 COM3 Y5 Y7 COM4 Y1 Y3 COM5 Y5 Y7
FX0N-40ER-DS	COM X0 X2 X4 X6 X0 X2 X4 X6 X0 X2 X4 X6
	24V COM0 COM1 COM2 Y3 COM3 Y5 Y7 COM4 Y1 Y3 COM5 Y5 Y7
FX0N-40ET-DSS	COM X0 X2 X4 X6 X0 X2 X4 X6 X0 X2 X4 X6
	24V +V0 +V1 +V2 Y3 +V3 Y5 Y7 +V4 Y1 Y3 +V5 Y5 Y7

■ Modular Extension Units MELSEC FX0N

FX0N-16EYT-ES/UL	+V0 Y1 Y3 +V1 Y5 Y7
	Y0 Y2 Y4 Y6
FX0N-16EYR-ES/UL	COM1 Y1 Y3 COM2 Y5 Y7
	Y0 Y2 Y4 Y6
FX0N-16EX-ES/UL	S/S X1 X3 X5 X7
	X0 X2 X4 X6

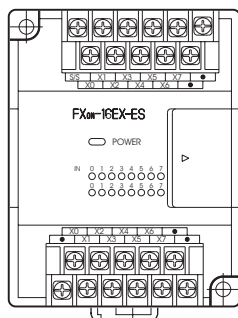

FX0N-16EX-ES/UL	X0 X2 X4 X6 X1 X3 X5 X7
FX0N-16EYR-ES/UL	Y0 Y2 Y4 Y6 COM3 Y1 Y3 COM4 Y5 Y7
FX0N-16EYT-ES/UL	Y0 Y2 Y4 Y6 +V2 Y1 Y3 +V3 Y5 Y7

FX0N-8EYT-ESS/UL	+V0 Y1 Y3 +V1 Y5 Y7
	Y0 Y2 Y4 Y6
FX0N-8EYR-ES/UL	COM1 Y1 Y3 COM2 Y5 Y7
	Y0 Y2 Y4 Y6
FX0N-8EX-ES/UL	S/S X1 X3 X5 X7
	X0 X2 X4 X6
FX0N-8ER-ES/UL	S/S X1 X3 COM Y1 Y3
	X0 X2 Y0 Y2

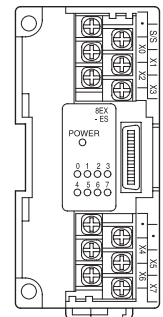
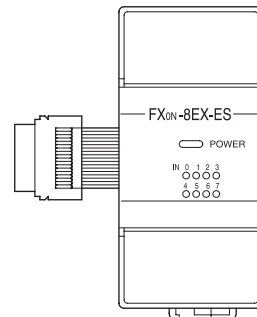

BASICS



Compact Extension Units MELSEC FX2N

BASICS



FX2N-32ET-ESS/UL	≡	S/S	0V	X0	X2	X4	X6	X0	X2	X4	X6	•
	L	N	•	24V	X1	X3	X5	X7	X1	X3	X5	X7
FX2N-32ER-ES/UL	≡	S/S	0V	X0	X2	X4	X6	X0	X2	X4	X6	•
	L	N	•	24V	X1	X3	X5	X7	X1	X3	X5	X7

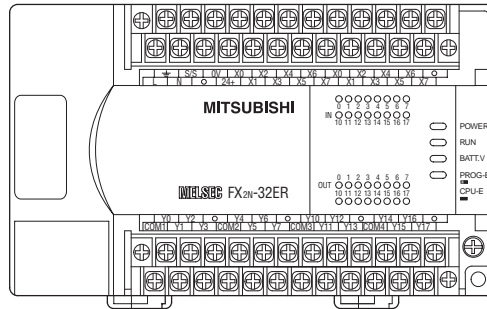

FX2N-32ER-ES/UL	Y0	Y2	•	Y4	Y6	•	Y0	Y2	•	Y4	Y6	•
	COM1	Y1	Y3	COM2	Y5	Y7	COM3	Y1	Y3	COM4	Y5	Y7
FX2N-32ET-ESS/UL	Y0	Y2	•	Y4	Y6	•	Y0	Y2	•	Y4	Y6	•
	+V0	Y1	Y3	+V1	Y5	Y7	+V2	Y1	Y3	+V3	Y5	Y7

FX2N-48ET-DS	≡	S/S	0V	X0	X2	X4	X6	X0	X2	X4	X6	•
	⊕	⊖	•	24V	X1	X3	X5	X7	X1	X3	X5	X7
FX2N-48ET-ES/UL	≡	S/S	0V	X0	X2	X4	X6	X0	X2	X4	X6	•
	L	N	•	24V	X1	X3	X5	X7	X1	X3	X5	X7
FX2N-48ER-DS	≡	S/S	0V	X0	X2	X4	X6	X0	X2	X4	X6	•
	⊕	⊖	•	24V	X1	X3	X5	X7	X1	X3	X5	X7
FX2N-48ER-ES/UL	≡	S/S	0V	X0	X2	X4	X6	X0	X2	X4	X6	•
	L	N	•	24V	X1	X3	X5	X7	X1	X3	X5	X7

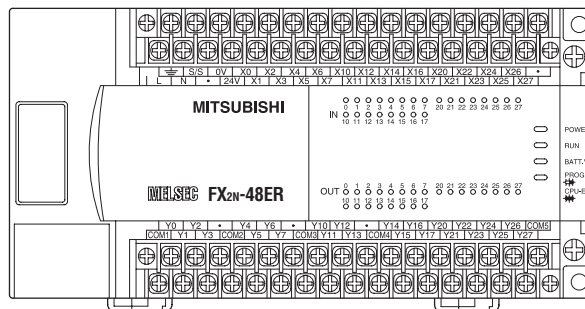

FX2N-48ER-ES/UL	Y0	Y2	•	Y4	Y6	•	Y0	Y2	•	Y4	Y6	Y0	Y2	Y4	Y6	COM5
	COM1	Y1	Y3	COM2	Y5	Y7	COM3	Y1	Y3	COM4	Y5	Y7	Y1	Y3	Y5	Y7
FX2N-48ER-DS	Y0	Y2	•	Y4	Y6	•	Y0	Y2	•	Y4	Y6	Y0	Y2	Y4	Y6	COM5
	COM1	Y1	Y3	COM2	Y5	Y7	COM3	Y1	Y3	COM4	Y5	Y7	Y1	Y3	Y5	Y7
FX2N-48ET-ES/UL	Y0	Y2	•	Y4	Y6	•	Y0	Y2	•	Y4	Y6	Y0	Y2	Y4	Y6	+V4
	+V0	Y1	Y3	+V1	Y5	Y7	+V2	Y1	Y3	+V3	Y5	Y7	Y1	Y3	Y5	Y7
FX2N-48ET-DS	Y0	Y2	•	Y4	Y6	•	Y0	Y2	•	Y4	Y6	Y0	Y2	Y4	Y6	+V4
	+V0	Y1	Y3	+V1	Y5	Y7	+V2	Y1	Y3	+V3	Y5	Y7	Y1	Y3	Y5	Y7

■ Modular Extension Units MELSEC FX2N

FX2N-16EX-ES/UL

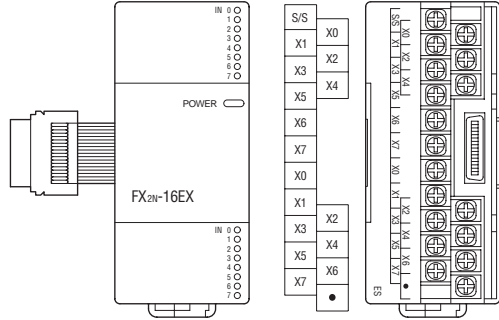

FX2N-16EYT-ESS/UL

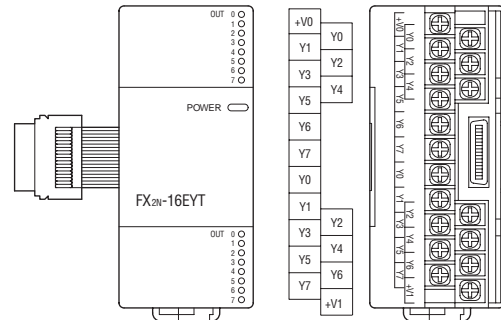

FX2N-16EYR-ES/UL

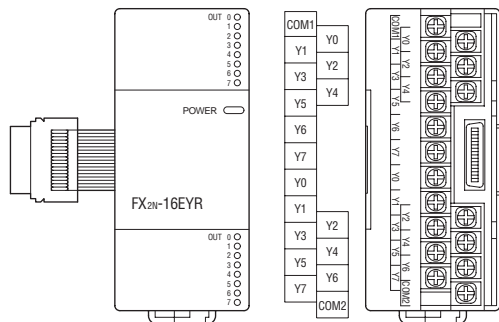

■ Extension Adapter Boards MELSEC FX1N

FX1N-4EX-BD

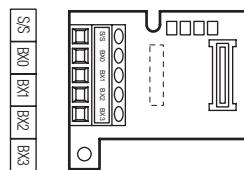

FX1N-2EYT-BD

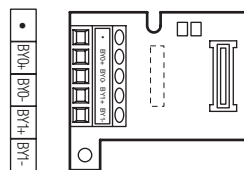

BASICS



■ Analog Modules MELSEC FX2N

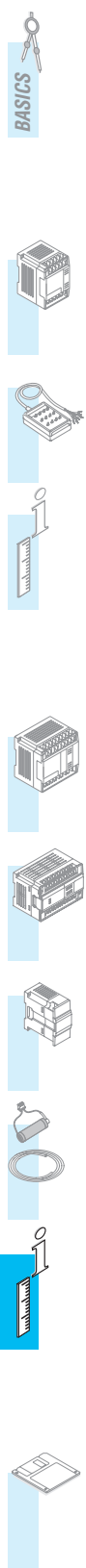

FX2N-2AD

V IN2	I IN2	COM2
V IN1	I IN1	COM1

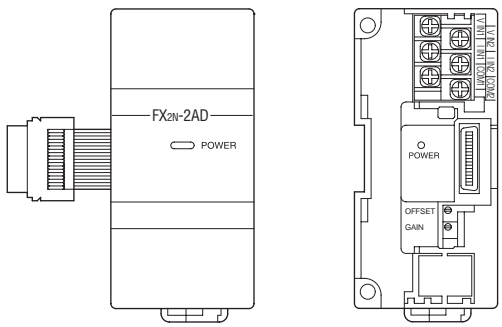

FX2N-2DA

VOUT2	IOUT2	COM2
VOUT1	IOUT1	COM1

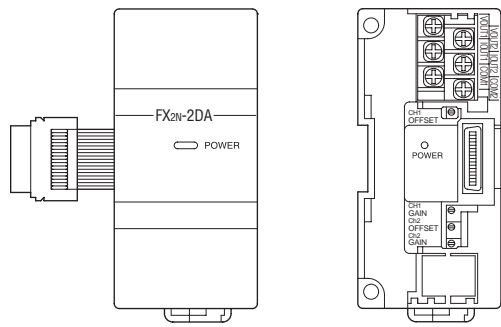

FX2N-4AD

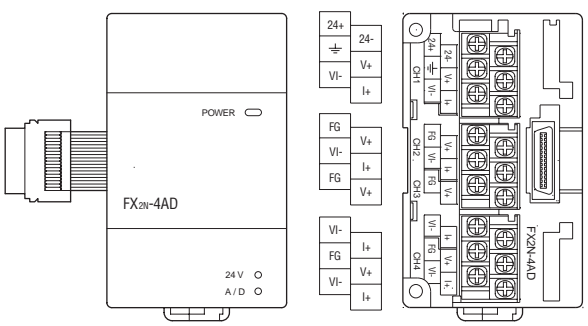

FX2N-4DA

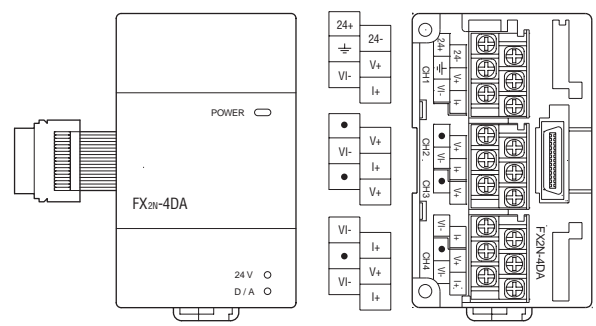

FX2N-4AD-TC

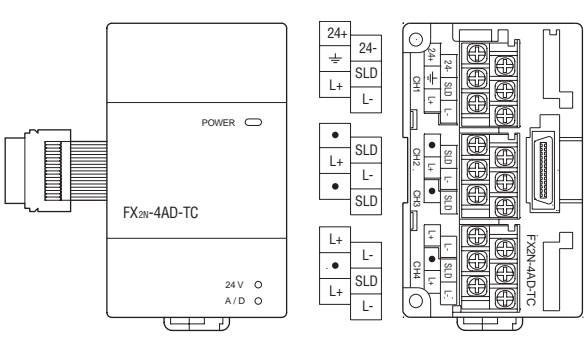

FX2N-4AD-PT

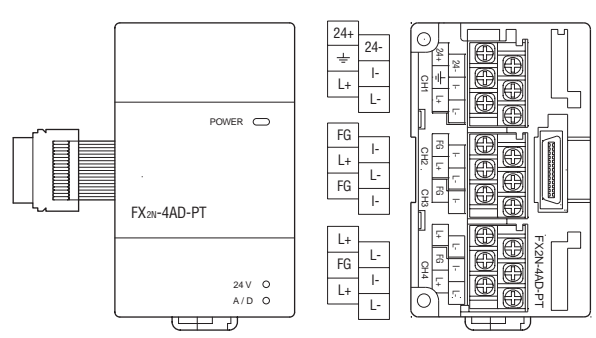

■ Analog Modules MELSEC FX0N / FX2N

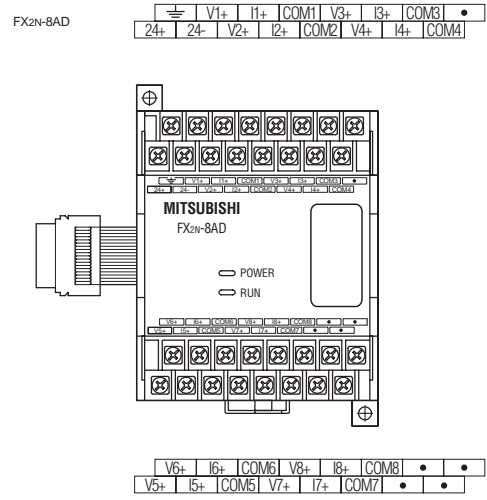
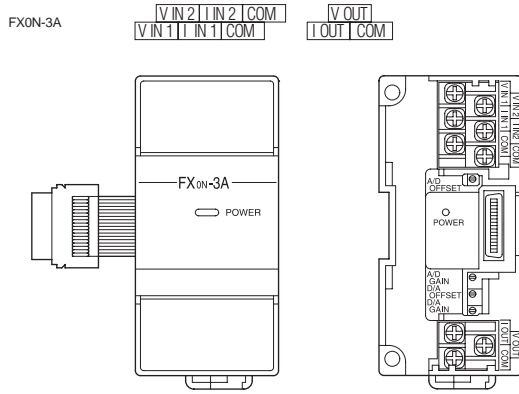

■ Analog Adapter Boards MELSEC FX1N

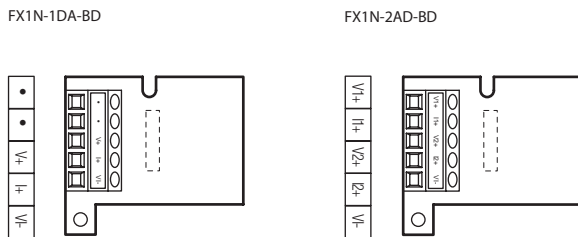

BASICS



Network Modules MELSEC FX0N / FX2N

BASICS



FX0N-32NT-DP

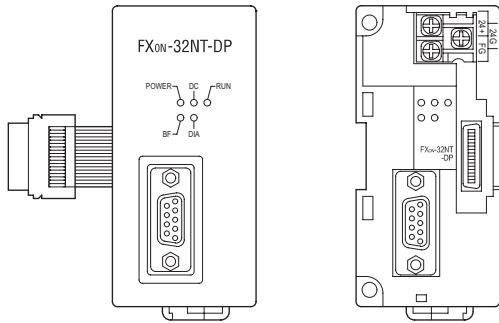

FX2N-32CCL

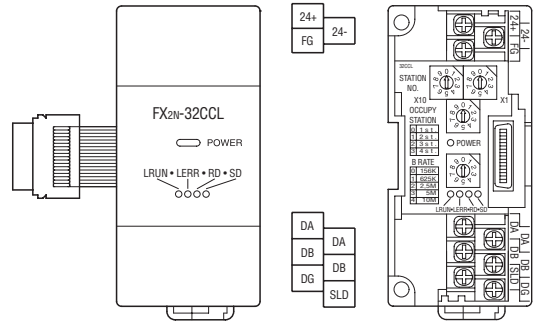

FX2N-32DP-IF



FX2N-32DP-IF-D

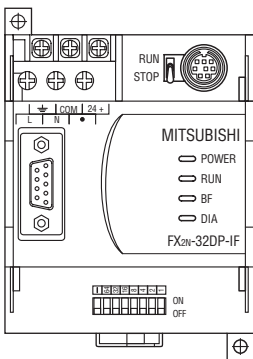
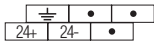

FX2N-16CCL-M

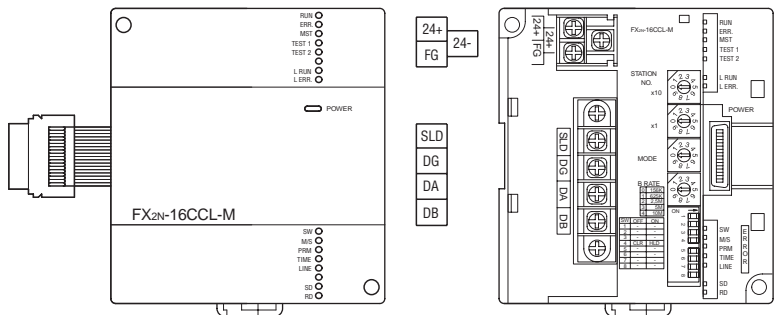

FX2N-32ASI-M

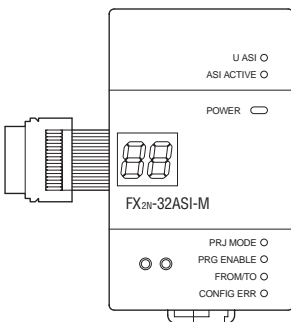
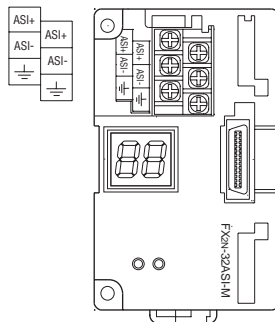

FX2N-16LNK-M

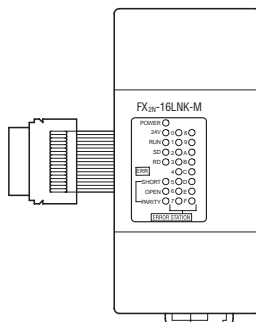
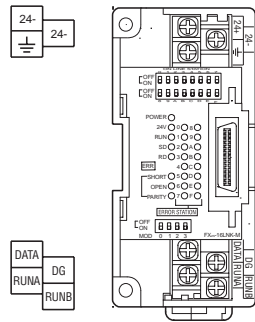

■ Network Modules MELSEC FX2N

FX2N-64DNET

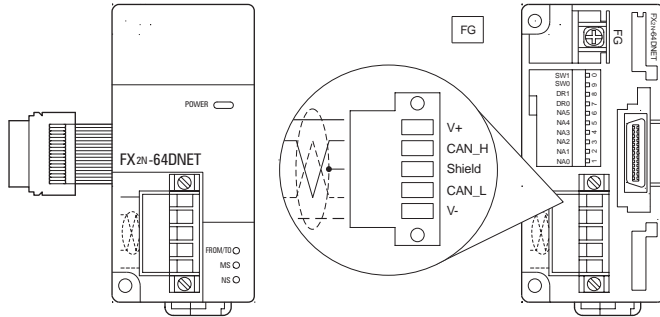

■ Communication Modules MELSEC FX0N / FX2N

FX0N-485ADP

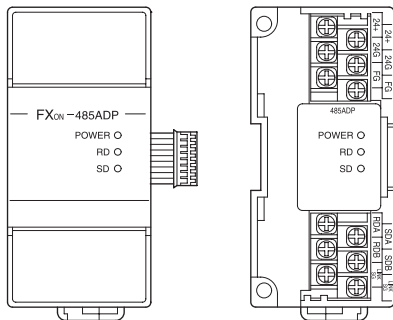

FX0N-232ADP

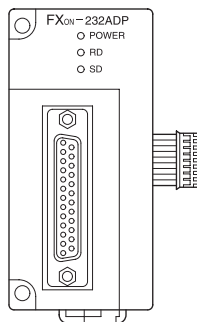

FX2N-232IF

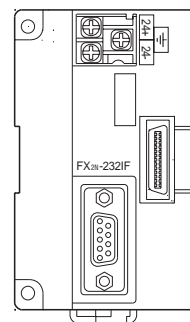
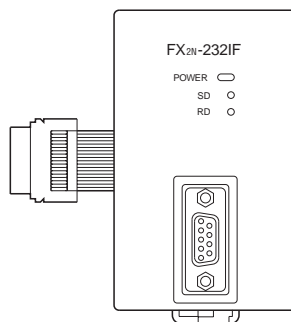

BASICS



BASICS



Special Function Modules MELSEC FX0N / FX1N / FX2N

FX2N-1PG

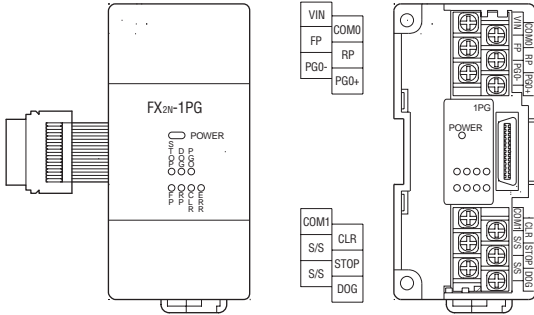

FX2N-10PG

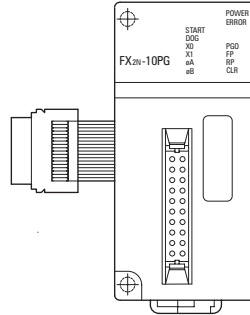

FX2N-2LC

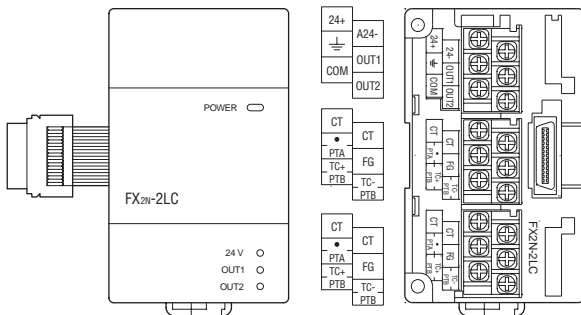

FX2N-1HC

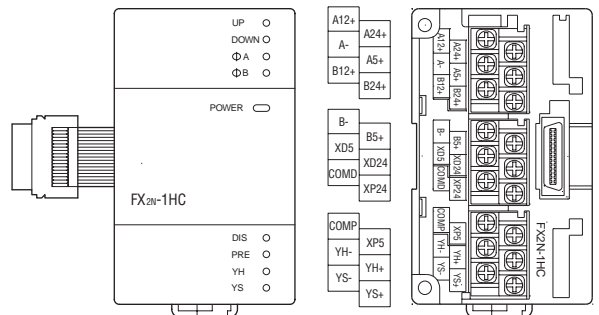

FX2N-10GM

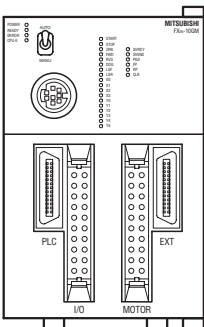

FX2N-20GM

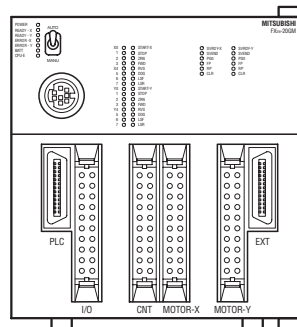

CON1		Y-Achse		CON2		X-Achse		CON3		X-Achse		CON4		Y-Achse	
Y00	○ ○	X00	○ ○	START	○ ○	START	○ ○	SVRDY	○ ○	SVEND	○ ○	SVRDY	○ ○	SVEND	○ ○
Y01	○ ○	X01	○ ○	STOP	○ ○	STOP	○ ○	COM2	○ ○	COM2	○ ○	CLR	○ ○	COM6	○ ○
Y02	○ ○	X02	○ ○	ZRN	○ ○	ZRN	○ ○	CLR	○ ○	PG0	○ ○	COM7	○ ○	PG0	○ ○
Y03	○ ○	X03	○ ○	FWD	○ ○	FWD	○ ○	COM3	○ ○	COM4	○ ○	COM8	○ ○	COM8	○ ○
Y04	○ ○	X04	○ ○	RVS	○ ○	RVS	○ ○	○ ○	○ ○	○ ○	○ ○	○ ○	○ ○	○ ○	○ ○
Y05	○ ○	X05	○ ○	DOG	○ ○	DOG	○ ○	FP	○ ○	RP	○ ○	FP	○ ○	RP	○ ○
Y06	○ ○	X06	○ ○	LSF	○ ○	LSF	○ ○	VIN	○ ○	VIN	○ ○	VIN	○ ○	VIN	○ ○
Y07	○ ○	X07	○ ○	LSR	○ ○	LSR	○ ○	VIN	○ ○	VIN	○ ○	VIN	○ ○	VIN	○ ○
COM1	○ ○	COM1	○ ○	COM1	○ ○	COM1	○ ○	COM5	○ ○	COM5	○ ○	COM9	○ ○	COM9	○ ○
								ST1	○ ○	ST2	○ ○	ST3	○ ○	ST4	○ ○

Dimensions of Base Units FX1N

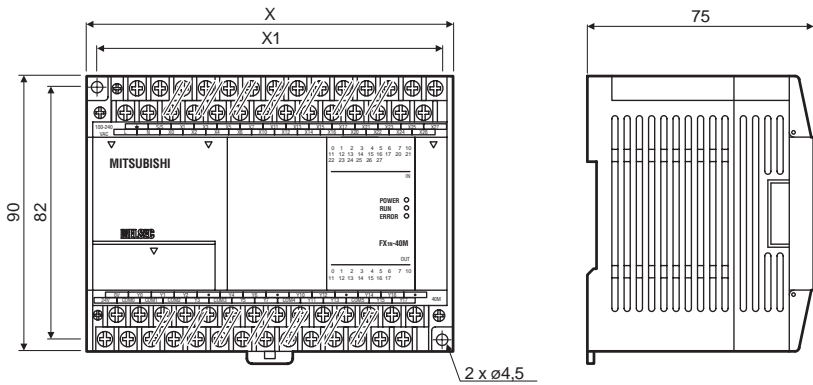

Type	X (in mm)
FX1N-14MR	90
FX1N-14MT	90
FX1N-24MR	90
FX1N-24MT	90
FX1N-40MR	130
FX1N-40MT	130
FX1N-60MR	175
FX1N-60MT	175

Dimensions of Compact Extension Units FX0N

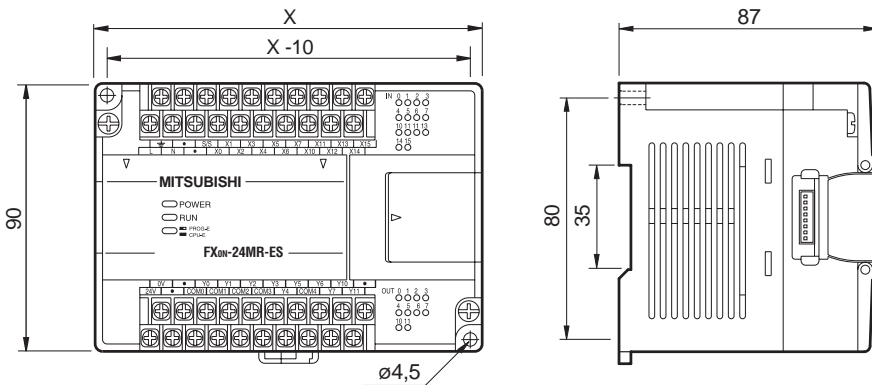

Type	X (in mm)
FX0N-40ER-DS	150
FX0N-40ER-ES/UL	150
FX0N-40ET-DSS	150

Dimensions of Modular Extension Units and Special Function Modules MELSEC FX0N

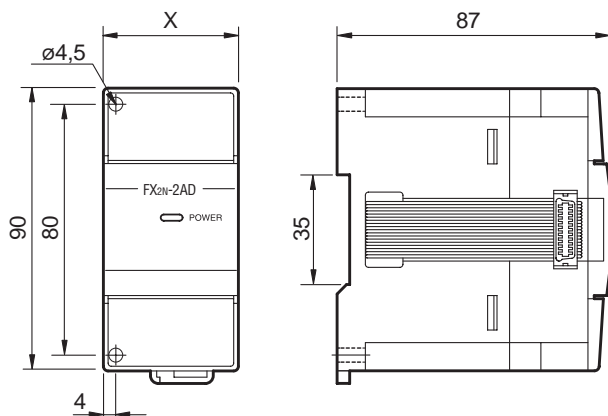

Type	X (in mm)
FX0N-8ER-ES/UL	43
FX0N-8EX-ES/UL	43
FX0N-8EYR-ES/UL	43
FX0N-8EYT-ESS/UL	43
FX0N-16EX-ES/UL	70
FX0N-16EYR-ES/UL	70
FX0N-16EYT-ES/UL	70
FX0N-232ADP	43
FX0N-3A	43
FX0N-32NT-DP	43
FX0N-485ADP	43



Dimensions of Base Units MELSEC FX2N

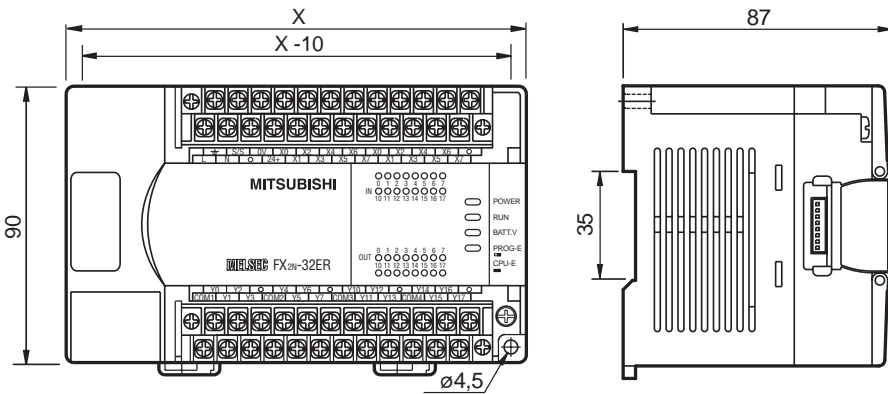

Base Units

Type	X (in mm)
FX2N-16M	130
FX2N-32M	150
FX2N-48M	182
FX2N-64M	220
FX2N-80M	285
FX2N-128M	350

Dimensions of Compact and Modular Extension Units MELSEC FX2N

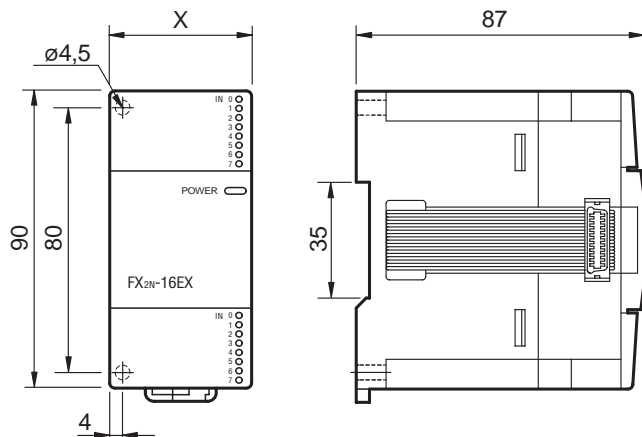

Compact Extension Units

Type	X (in mm)
FX2N-32ER-ES/UL	150
FX2N-32ET-ESS/UL	150
FX2N-48ER-DS	182
FX2N-48ER-ES/UL	182
FX2N-48ET-DSS	182
FX2N-48ET-ESS/UL	182

Modular Extension Units

Type	X (in mm)
FX2N-16EX-ES/UL	40
FX2N-16EYR-ES/UL	40
FX2N-16EYT-ESS/UL	40

Dimensions of Extension Adapter Boards FX1N

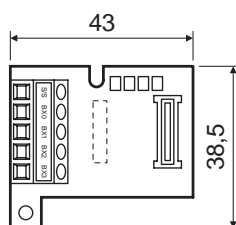

Dimensions of Special Function Modules MELSEC FX2N

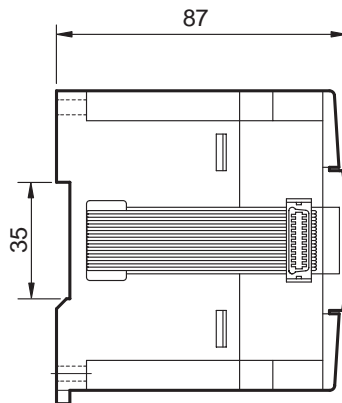
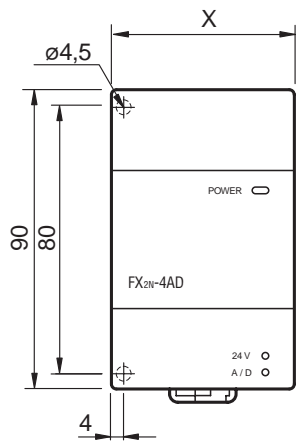

Special Function Modules FX2N

Type	X (in mm)
FX2N-2DA	43
FX2N-2AD	43
FX2N-4DA	55
FX2N-4AD	55
FX2N-4AD-TC	55
FX2N-4AD-PT	55
FX2N-1HC	55
FX2N-1PG-E	43
FX2N-10PG	43
FX2N-16LNK-M	43
FX2N-2LC	55
FX2N-232-IF	55
FX2N-32ASI-M	50
FX2N-16CCL-M	85
FX2N-32CCL	43
FX2N-64DNET	43

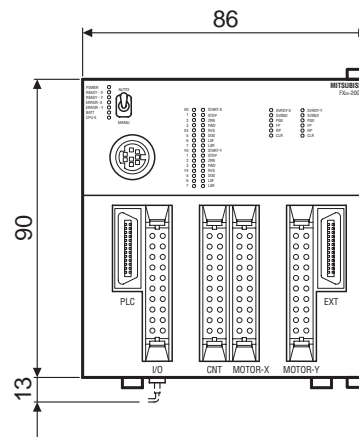
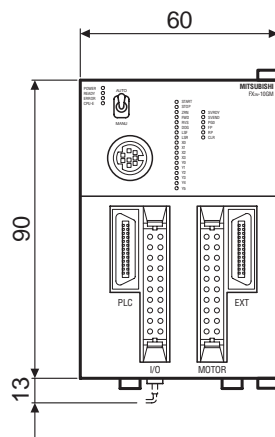
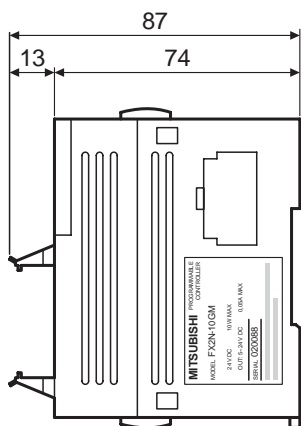
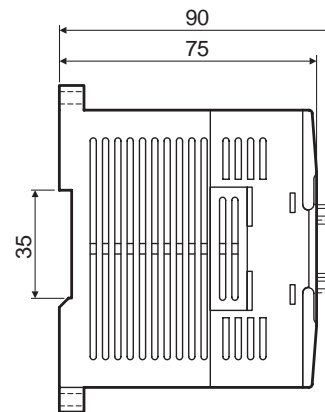
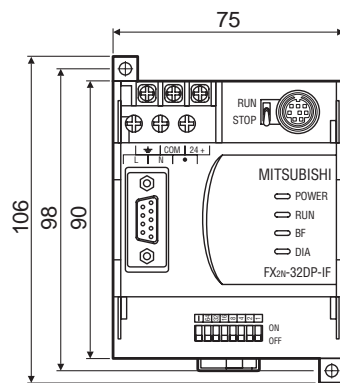
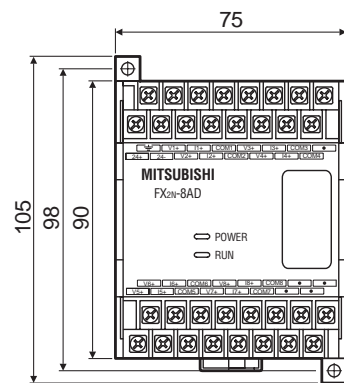

BASICS



Dimensions of Accessories

BASICS

FX-485PC-IF

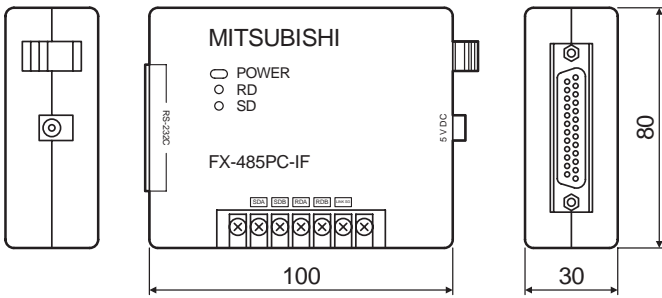

FX1N-EEPROM-8L

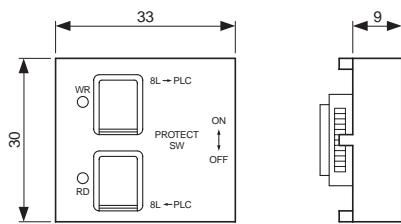

Communication adapter FX1N

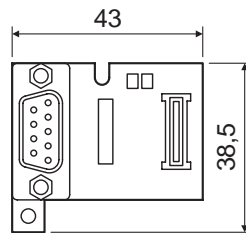

Communication adapter FX2N

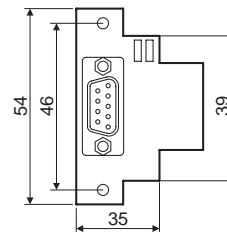

FX1N-5DM

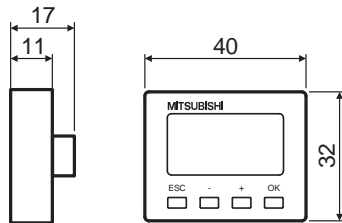

FX2N-10DM-E

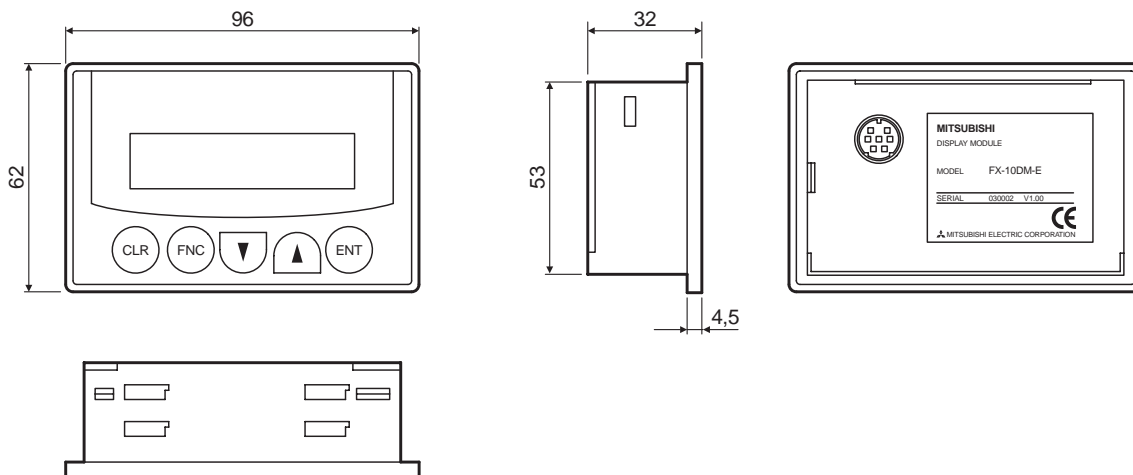

MELSOFT – Programming and Documentation Software for Standard Personal Computers



With the MELSOFT software family Mitsubishi Electric offers efficient software packages helping to reduce programming and setup times to a high degree. The MELSOFT software family provides instant access, direct communications, compatibility, and open exchange of variables.

The MELSOFT family comprises:

- Programming packages like FX-PCS/WIN, GX Developer and GX IEC Developer
- Network configuration software like for example GX Configurator DP
- Visualization software like for example MX SCADA
- Software for a dynamic data exchange like MX Change
- Various development software for operator terminals (please refer to the HMI Technical Catalogue)

FX-PCS/WIN is recommended as a cost-effective beginners package for the FX family. This package offers a quick and easy introduction to programming.

GX Developer FX is the right decision for a universal programming package. If additionally to the FX1N and FX2N series the programming of the A/Q series should be included, the GX Developer is the right choice.

For structured programming the IEC1131.3 (EN 61131-3) conform programming software GX IEC Developer is recommended.

For detailed information please order our separate MELSOFT brochure.



FX-PCS/WIN-E

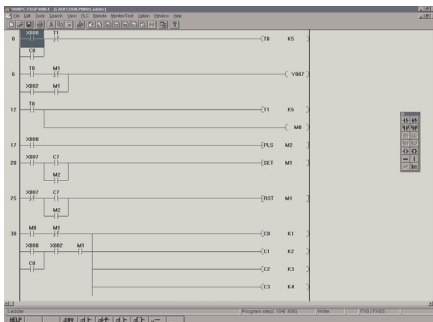

FX-PCS/WIN is the standard programming software for the MELSEC FX family and combines all functions of the former version MELSEC MEDOC with the user guidance of Microsoft Windows®.

FX-PCS/WIN provides the user with facilities for structured programming, function modules and many different diagnostic functions.

This software possesses all Windows-specific benefits and is especially geared to the new FX series.

The software is supplied without an SC-09 programming cable, which can be ordered separately. This cable is needed for the connection between the PLC and a serial interface of a personal computer.

FX-PCS/WIN can be run under Windows 3.11, Windows 95/98/ME and Windows NT/2000.



Software		FX-PCS/WIN-E V3
Series		Whole FX family
Language		English, German, French, Italian, Spanish (multilingual)
Disk type		CD ROM
Order information		
Art. no.		132179
Accessory		
		Programming cable SC-09, art. no.: 43393

PLC Programming Software

■ GX Developer

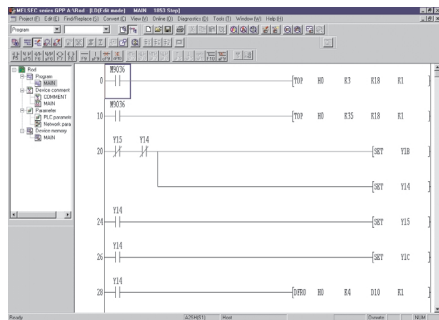

GX Developer is the standard programming software for all MELSEC PLC series and combines all functions of MELSEC MEDOC with the user guidance of Microsoft Windows.

With this software you can comfortably create PLC programs alternatively in the form of Ladder Diagrams or Instruction Lists. Both forms of representation can be toggled easily during operation.

Besides efficient monitoring and diagnostics functions GX Developer features an offline simulation of any PLC type.

With GX Developer all MELSEC PLCs from the FX1S to the Q25H (Q series) are supported.

The GX Developer FX is limited to the programming of the FX series.

This software provides all the Windows-specific advantages and is especially suited to all MELSEC PLCs.

The software is supplied without an SC-09 programming cable, which can be ordered separately. This cable is needed for the connection between the PLC and a serial interface of a personal computer.

GX Developer can be run under Windows 95/98 and Windows NT/2000.

Software	GX Developer FX V0704-1LOC-G	GX Developer FX V0704-1LOC-E	GX Developer V0704-1LOC-G	GX Developer V0704-1LOC-E
Series	FX1S, FX1N, FX2N	FX1S, FX1N, FX2N	All MELSEC PLCs	All MELSEC PLCs
Language	German	English	German	English
Disk type	CD ROM	CD ROM	CD ROM	CD ROM
Order information	Art. no. 139480	139492	139456	139468
Accessory	Programming cable SC-09, art. no.: 43393			

■ GX IEC Developer

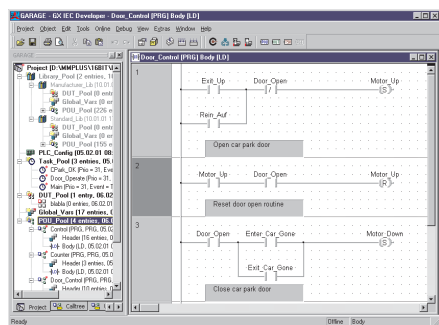

GX IEC Developer provides all functions of the pre-mentioned programs and in addition meets the programming standard: IEC 1131.3 (EN 61131). This makes the software ready for the programming standard of the future and offers beside the FX version in addition the full version as a basis for the on-leading programming of the MELSEC A and Q series.

GX IEC Developer can be run under Windows 95/98 and Windows NT/2000.

The software is supplied without an SC-09 programming cable, which can be ordered separately. This cable is needed for the connection between the PLC and a serial interface of a personal computer.

Software	GX IEC Developer FX V0400-1LOC-G	GX IEC Developer FX V0400-1LOC-E	GX IEC Developer V0400-1LOC-G	GX IEC Developer V0400-1LOC-E
Series	FX1S, FX1N, FX2N	FX1S, FX1N, FX2N	All MELSEC PLCs	All MELSEC PLCs
Language	German	English	German	English
Disk type	CD ROM	CD ROM	CD ROM	CD ROM
Order information	Art. no. 136482	136490	136459	136487
Accessory	Programming cable SC-09, art. no.: 43393			

Profibus Networks Software

■ GX Configurator DP

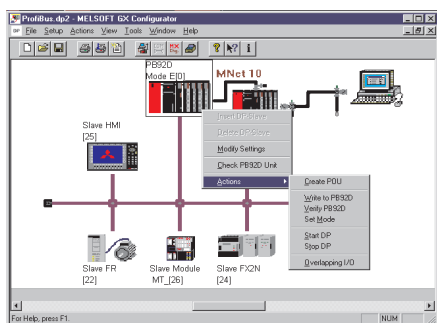

The GX Configurator DP is a user friendly configurations software for the open network PROFIBUS/DP.

The software package is a 32 bit application and runs under Windows 95/98 and Windows NT4.0. Configuration of all PROFIBUS/DP modules for the MELSEC Ans/QnAS and A/Q series and also the FX family is possible.

Due to the supported extended user parameters of a GSD file, easy parameter setting of PROFIBUS/DP slave devices is possible even for third-party devices.

The new GX Configurator DP enables the download of all configuration data via an overriding network.

All PROFIBUS modules are configured via the backside bus.

Software	GX Configurator DP V0500-1LOC-E	
Supported PROFIBUS/DP master modules for the Mitsubishi MELSEC series	A1S1J71PB92D, AJ71PB92D, QJ71PB92D	
Language	English / German	
Disk type	CD ROM	
Order information	Art. no.	145312
Accessory	Programming cable SC-09, art. no.: 43393	

■ GX Monitor DP

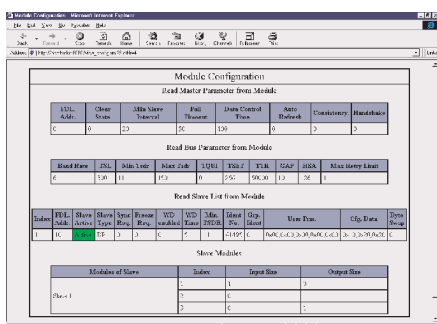

With the new GX Monitor DP Software it is possible to make Diagnostics in graphical or text for PROFIBUS/DP networks and PLC via Internet. With the use of the standard Internet Explorer® it is quite simple to use and easy to run on different PC platforms.

This software can be used independent or in combination with GX Configurator DP.

Software	GX Monitor DP V0100-1LOC-E	
Supported PROFIBUS/DP master modules for the Mitsubishi MELSEC series	A1S1J71PB92D, AJ71PB92D, QJ71PB92D, QJ71PB93D	
Language	English	
Disk type	CD ROM	
Order information	Art. no.	143971
Accessory	Programming cable SC-09, art. no.: 43393	

■ PROFIBUS Master Simulator

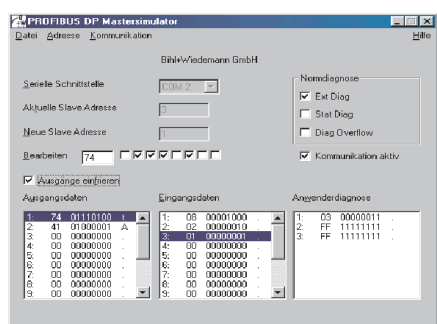

The PROFIBUS/DP Master Simulator is an easy to use and versatile utility for the specifications exchange with PROFIBUS/DP slaves. For this purpose the PROFIBUS/DP Master Simulator is capable of exchanging the specifications with many slaves even without a GSD file, a type file, and a PROFIBUS/DP master. Without further input or additional files PROFIBUS/DP slaves can be started using their base I/O range.

Input specifications can be read and output specifications can be written. Furthermore, the PROFIBUS/DP Master Simulator

obviously supports GSD files as well as entering particular configurations for starting the specifications exchange with PROFIBUS/DP slaves. Addressing is supported either. The PROFIBUS/DP Master Simulator provides an option to scan the entire PROFIBUS/DP for connected participants and display them graphically. The PROFIBUS/DP Master Simulator is a development of the company Bihl & Wiedemann GmbH (www.bihl-wiedemann.de) and is not distributed by Mitsubishi Electric.

Visualization Software and Software for Dynamic Data Exchange

■ MX Change

BASICS

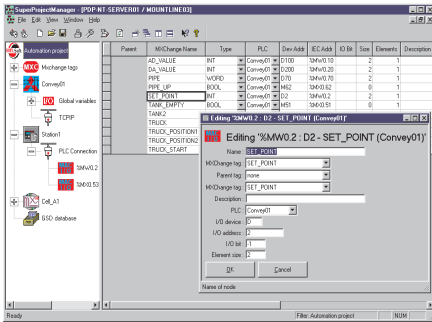

MX Change is integrated in the MELSOFT family as the “heart of automation”. The software package consists of a Server and a Super Project Manager, other automation programs can be connected to. Since MX Change operates across a network, any variable once declared can be used by all other systems connected to the database.

Through this method following the principle “define once and use anywhere” the development time can even be decreased drastically. The software runs under Windows 95/98 and Windows NT.

Software	MX Change V0210-1LOC-E	MX Change 200T V0210-1LOC-E	MX Change 200T V0210-0LOC-DEMO
Language	English	English	English
Executable tags		2,000	200
Disk type	CD ROM	CD ROM	CD ROM
Order information	Art. no. 141997	141996	141995

■ MX OPC Server

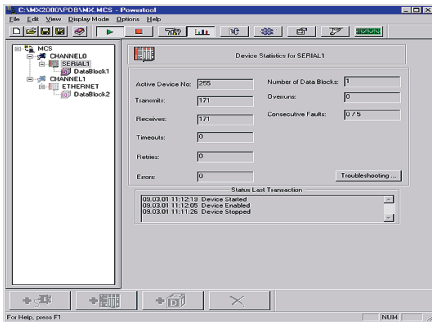

The OPC standard was developed for manufacturer independent communications between processes and Microsoft Windows® applications in client/server architecture. OPC means "OLE for Process Control" and represents an application of the Microsoft DCOM technology (Distributed Component Object Model). In contrast to Active-X the OPC based data exchange especially features a higher performance.

The MX OPC server is a standardized software interface that enables Microsoft Windows® applications to access a Mitsubishi PLC quick and easily. The software runs under Windows 95/98 and Windows NT/2000.

Software	MX OPC Server V0100-1LOC-E
Series	All MELSEC PLCs
Language	English
Disk type	CD ROM
Order information	Art. no. 139793

MX Components

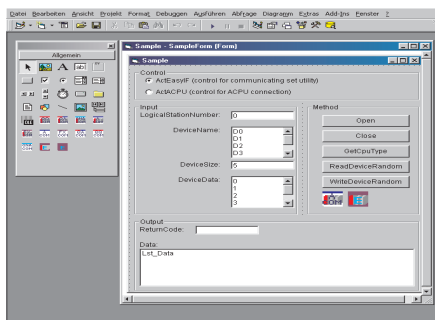

This software provides you with powerful Active-X elements. An internal driver manages the complete communications between your Microsoft Windows application and your process. Via MX components and a programming language (e.g. Visual Basic, Visual C++, etc.) you can easily create your own PC applications or integrate existing PC applications.

Moreover, via MX Components and VBA the complete MS Office range is at your service. Without high effort you can integrate online process data of a Mitsubishi PLC in your existing office software (e.g. MS Access or MS Excel etc.). The software runs under Windows 95/98 and Windows NT/2000.

Software	MX Components V0200-1LOC-E
Series	All MELSEC PLCs
Language	English
Disk type	CD ROM
Order information	Art. no. 142848



MX SCADA

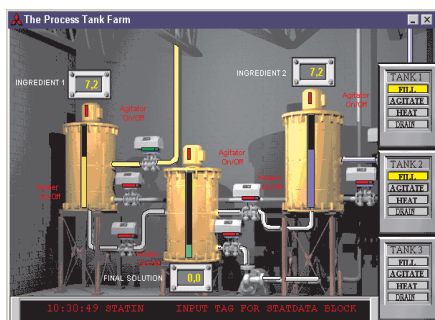

MX SCADA is a process visualization system that can handle everything from simple installations to complex production control systems. The software package can administer up to 100,000 objects. A variety of interfaces are supported, including ETHERNET.

The software runs under Windows 95/98 and Windows NT and is available in a variety of different versions geared to the objects to be handled.

Software	Development version	Run-time version	Demo version
Series	All MELSEC PLCs	All MELSEC PLCs	All MELSEC PLCs
Language	English	English	English
Disk type	CD ROM	CD ROM	CD ROM
Order information	Art. no. On request	On request	65135



BASICS

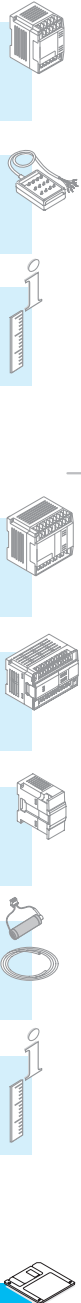

■ Hand-Held Programming Unit FX-10 P-E and FX-20 P-E

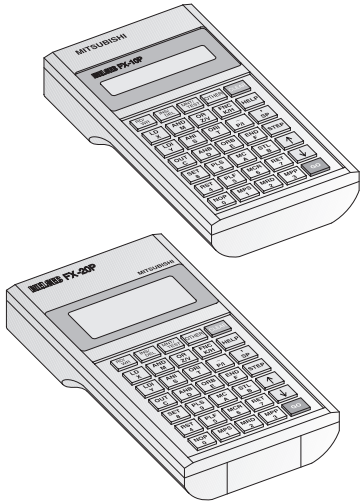

These small hand-held programming units designed for industry have a user-friendly keyboard and a clearly laid out, back-lit LC display. On both programming units, the MELSEC FX family is programmed in the list of instructions.

The FX-20 P has an integrated CMOS-RAM with capacitor buffering. This ensures storage of the PLC program and its duplication, for example for series machines.

Specifications	FX-10 P-E	FX-20 P-E
General specifications	Conforms to base units FX1S, FX1N, FX2N	
Ambient temperature	0 – 40 °C	0 – 40 °C
Ambient relative humidity (non-condensing)	35 – 85 %	35 – 85 %
Power supply	DC 5 ±5 % via PLC	DC 5 ±5 % via PLC
Current consumption	mA 120	150
Display	LCD	LCD (with backlight)
Character display	16 x 2	16 x 4
Connectable PLC	FX1S, FX1N, FX2N ^②	FX1S, FX1N, FX2N ^①
Keyboard	35	35
Memory	—	8,000 steps PLC-program
Data security	—	Data is safed up to 3 days by capacitor.
Cable	—	FX-20P-CAB
Weight	kg 0.25	0.4
Dimensions (W x H x D)	mm 85 x 160 x 27	90 x 170 x 30
Order information	Art. no. 136931	23802

^① from programming unit version 3.00, ^② from version 4.00



Programming Cable SC-09

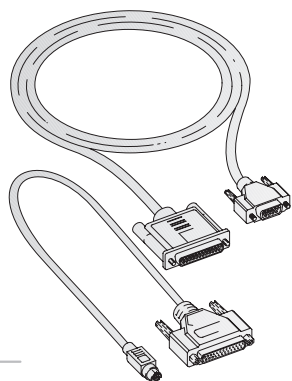

The SC-09 programming cable is used for the connection between the PLC and a serial interface of a personal computer. The cable is divided into 2 parts and thus universally applicable for all Mitsubishi PLCs.

SC-09

Order information Art. no. 43393

Connection Cable

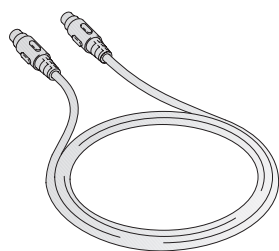

With the connection cable FX-20P-CAB0 the peripheral units with 8-pin Mini-DIN connector are connected to units of the FX1S, FX1N or FX2N series.

Units with 25-pin D-Sub connector are connected to the FX1S, FX1N or FX2N series with the cable FX-20P-CAB.

Specifications	FX-20P-CAB	FX-20P-CAB0
Cable type	Connection cable	Connection cable
Length	cm 150	300
For connecting to controller	FX	FX1S, FX1N, FX2N
Order information	Art. no. 30815	55917

EPROM Writer FX-20 P-RWM

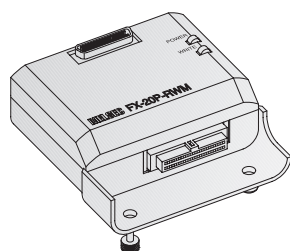

The EPROM writer FX-20 P-RWM is plugged directly into the hand-held programming unit FX-20 P-E. It is used for transferring the PLC programs of the MELSEC FX controller to the EPROM memory cassette FX-EPROM-8.

Conversely, existing programs can be read from the FX-EPROM-8 memory cassette into the CMOS-RAM of the MELSEC FX controller and program comparisons carried out.

FX-20 P-RWM

Order information Art. no. 23818

ORDER FORM

<p>mitsubishi electric europe b.v. Industrial Automation / German Branch Gothaer Str. 8 D-40880 Ratingen</p> <p>Fax: +49 2102 486-7170</p>	<p>Company:</p> <p>Department:</p> <p>Street:</p> <p>Address:</p> <p>Phone:</p> <p>Fax:</p>
--	---

Order declaration

Pos.	Number	Item (type)	Article number	Description	Remarks

Notes when ordering:
 When ordering, please use only the type designations and article numbers shown in this catalogue.

Analog adapter board	37	FX1N-60MT-ESS/UL	27	FX2N-485BD	60
Analog module	38	FX1N-232BD	46	FX2N-CNV-BC	65
Base units		FX1N-422BD	46	FX2N-CNV-BD	62
FX1S series	12	FX1N-485BD	60	FX2N-CNV-IF	62
FX1N series	26	FX1N-CNV-BD	62	FX2N-ROM-E1	63
FX2N series	28	FX1N-EEPROM-8L	14	FX2NC-32BL	63
Batteries	63	FX1S-10MR-DS	12	FX-EEPROM-4	63
Combination options	21	FX1S-10MR-ES/UL	12	FX-EEPROM-8	63
Compact extension units	32	FX1S-10MT-DSS	12	FX-EEPROM-8L	63
Connection cables	65, 89	FX1S-10MT-ESS/UL	12	FX-EEPROM-8	63
Configuration FX1N/FX2N	24	FX1S-14MR-DS	12	FX-EEPROM-16	63
CR01-R2/R4 SET	61	FX1S-14MR-ES/UL	12	FX-PCS/WIN	83
CR01-R4/R4	61	FX1S-14MT-DSS	12	FX-RAM-8	63
CR01-R4/R4	61	FX1S-14MT-ESS/UL	12	FX-ROM SOC1	62
CR01-R4/R4	61	FX1S-20MR-DS	13	General specifications	
Description of units		FX1S-20MR-ES/UL	13	FX1S series	12
FX1S series	11	FX1S-20MT-DSS	13	FX1N/FX2N series	25
FX1N/FX2N series	20	FX1S-20MT-ESS/UL	13	GX Configurator DP	85
Digital I/Os	31	FX1S-30MR-DS	13	GX (IEC) Developer	84
Dimensions		FX1S-30MR-ES/UL	13	Input SIM:	15, 65
FX1S series	17	FX1S-30MT-DSS	13	Interface converter	61
FX0N series	79	FX1S-30MT-ESS/UL	13	Memory cassettes	63
FX1N series	79	FX2N-1HC	43	Modular extension units	34
FX2N series	80	FX2N-1PG-E	43	MX Change	86
Special function modules	81	FX2N-2AD	39	MX Components	87
Accessory	82	FX2N-2DA	39	MX OPC Server	86
Display module	14, 64	FX2N-2LC	42	MX SCADA	87
EPROM loader	89	FX2N-4AD	40	Networks (overview)	8
EPROM/EEPROM cassettes	15, 63	FX2N-4DA	40	1:n multidrop	59
Extension units		FX2N-4AD-PT	42	AS interface	49
compact	32	FX2N-4AD-TC	41	MELSEC I/O Link	51
modular	34	FX2N-8AD	41	CC Link	53
F2-40BL	63	FX2N-8AV-BD	37	DeviceNet	57
FX-10DM-E	64	FX2N-10GM	44	Peer-to-Peer	59
FX-10/FX20P-E	88	FX2N-10PG	43	PROFIBUS/DP	47
FX-20P-RWM	89	FX2N-10GM	44	Power consumption	23
FX-485PC-IF	61	FX2N-20GM	44	Programming units	88
FX0N-3A	38	FX2N-20GM	44	PROM adapter	62
FX0N-8ER-ES/UL	34	FX2N-20GM	44	SC06N-PG	61
FX0N-8EX-ES/UL	34	FX2N-16CCCL-M	54	SC09 programming cable	89
FX0N-8EYR-ES/UL	34	FX2N-16EX-ES/UL	35	Software	83
FX0N-8EYT-ESS/UL	34	FX2N-16EYR-ES/UL	35	Special function modules	
FX0N-16EX-ES/UL	34	FX2N-16EYT-ESS/UL	35	Analog modules	38
FX0N-16EYR-ES/UL	34	FX2N-16LNK-M	52	Counter/positioning modules	43
FX0N-16EYT-ESS/UL	34	FX2N-16MR-DS	28	Communications modules	45, 60
FX0N-32NT-DP	48	FX2N-16MR-ES/UL	28	Description (general)	22
FX0N-40ER-ES/UL	32	FX2N-16MT-ESS/UL	28	Interface modules	45, 60
FX0N-40ER-DS	32	FX2N-32ASI-M	50	PROFIBUS modules	48
FX0N-40ET-DSS	32	FX2N-32CCL	55	Switch box, simulation strip	15, 65
FX0N-65EC	65	FX2N-32CCL	55	System data	
FX0N-232ADP	45	FX2N-32DP-IF	48	FX1S series	13
FX0N-485ADP	60	FX2N-32DP-IF-D	48	FX1N/FX2N series	25
FX1N-1DA-BD	38	FX2N-32ER-ES/UL	33	System description	
FX1N-2AD-BD	37	FX2N-32ET-ESS/UL	33	FX1S series	10
FX1N-2EYT-BD	36	FX2N-32MR-DS	28	FX1N series	18
FX1N-4EX-BD	36	FX2N-32MR-ES/UL	28	FX2N series	19
FX1N-5DM-E	14, 64	FX2N-32MT-DSS	28	General	4
FX1N-8AV-BD	36	FX2N-32MT-ESS/UL	28	System combination possibilities	21
FX1N-14MR-DS	26	FX2N-48ER-DS	33	Terminal assignment	
FX1N-14MR-ES/UL	26	FX2N-48ER-ES/UL	33	Analog modules	74
FX1N-14MT-DSS	26	FX2N-48ET-DSS	33	Base units FX1N	66
FX1N-14MT-ESS/UL	26	FX2N-48ET-ESS/UL	33	Base units FX2N	68
FX1N-24MR-DS	26	FX2N-48MR-DS	29	Extension units	71
FX1N-24MR-ES/UL	26	FX2N-48MR-ES/UL	29	FX1S series	16
FX1N-24MT-DSS	26	FX2N-48MT-DSS	29	Special function modules	76
FX1N-24MT-ESS/UL	26	FX2N-64DNET	58	Type designation	11
FX1N-40MR-DS	27	FX2N-64MR-DS	29		
FX1N-40MR-ES/UL	27	FX2N-64MR-ES/UL	29		
FX1N-40MT-DSS	27	FX2N-64MT-DSS	29		
FX1N-40MT-ESS/UL	27	FX2N-64MT-ESS/UL	29		
FX1N-60MR-DS	27	FX2N-80MR-DS	30		
FX1N-60MR-ES/UL	27	FX2N-80MR-ES/UL	30		
FX1N-60MT-DSS	27	FX2N-80MT-DSS	30		
		FX2N-80MT-ESS/UL	30		
		FX2N-128MR-ES/UL	30		
		FX2N-128MT-ESS/UL	30		
		FX2N-232BD	46		
		FX2N-232IF	45		
		FX2N-422BD	46		

HEADQUARTERS

MITSUBISHI ELECTRIC EUROPE B.V. **EUROPE**
 German Branch
 Gothaer Straße 8
D-40880 Ratingen
 Phone: +49 (0) 21 02 / 486-0
 Fax: +49 (0) 21 02 / 4 86-11 20
 e mail: megfamail@meg.mee.com

MITSUBISHI ELECTRIC EUROPE B.V. **FRANCE**
 French Branch
 25, Boulevard des Bouvets
F-92741 Nanterre Cedex
 Phone: +33 1 55 68 55 68
 Fax: +33 1 55 68 56 85
 e mail: factory.automation@fra.mee.com

MITSUBISHI ELECTRIC EUROPE B.V. **UK**
 UK Branch
 Travellers Lane
GB-Hatfield Herts. AL10 8 XB
 Phone: +44 (0) 1707 / 27 61 00
 Fax: +44 (0) 1707 / 27 86 95

MITSUBISHI ELECTRIC EUROPE B.V. **ITALY**
 Italian Branch
 Via Paracelso 12
I-20041 Agrate Brianza (MI)
 Phone: +39 039 6053 1
 Fax: +39 039 6053 312
 e mail: factory.automation@it.mee.com

MITSUBISHI ELECTRIC EUROPE B.V. **SPAIN**
 Spanish Branch
 Carretera de Rubí 76-80
E-08190 Sant Cugat del Vallés
 Phone: +34 9 3 / 565 3131
 Fax: +34 9 3 / 589 2948
 e mail: industrial@sp.mee.com

MITSUBISHI ELECTRIC CORPORATION **JAPAN**
 Office Tower "Z" 14 F
 8-12,1 chome, Harami Chuo-Ku
Tokyo 104-6212
 Phone: +81 3 / 622 160 60
 Fax: +81 3 / 622 160 75

MITSUBISHI ELECTRIC AUTOMATION **USA**
 500 Corporate Woods Parkway
Vernon Hills, IL 60061
 Phone: +1 847 / 478 21 00
 Fax: +1 847 / 478 22 83

EUROPEAN REPRESENTATIVES

GEVA GmbH **AUSTRIA**
 Wiener Straße 89
A-2500 Baden
 Phone: +43 (0) 2252 / 85 55 20
 Fax: +43 (0) 2252 / 488 60
 e mail: office@geva.co.at

Getronics b.v. **BELGIUM**
 Control Systems
 Pontbeeklaan 43
B-1731 Asse-Zellik
 Phone: +32 (0) 2 / 4 67 17 51
 Fax: +32 (0) 2 / 4 67 17 45
 e mail: infoautomation@getronics.com

TELECON CO. **BULGARIA**
 4, A. Ljapchev Blvd.
BG-1756 Sofia
 Phone: +359 92 / 97 44 05 8
 Fax: +359 92 / 97 44 06 1
 e mail: —

INEA CR d.o.o. **CROATIA**
 Drvinje 63
HR-10000 Zagreb
 Phone: +385 (0)1/ 36 67 140
 Fax: +385 (0)1/ 36 67 140
 e mail: —

AutoCont **CZECHIA**
 Control Systems s.r.o.
 Nemocnici 12
CZ-702 00 Ostrava 2
 Phone: +420 (0) 69 / 615 21 11
 Fax: +420 (0) 69 / 615 21 12
 e mail: petr.pustovka@autocont.cz

louis poulsen **DENMARK**
 Geminivej 32
DK-2670 Greve
 Phone: +45 (0) 43 / 95 95 95
 Fax: +45 (0) 43 / 95 95 91
 e mail: lpia@lpmail.com

UTU Elektrotehnika AS **ESTONIA**
 Pärnu mnt.160i
EE-11317 Tallinn
 Phone: +372 6 / 51 72 80
 Fax: +372 6 / 51 72 88
 e mail: utu@utu.ee

Beijer Electronics OY **FINLAND**
 Ansatie 6a
FIN-01740 Vantaa
 Phone: +358 (0) 9 / 886 77 500
 Fax: +358 (0) 9 / 886 77 555
 e mail: info@elc.beijer.fi

UTECO A.B.E.E. **GREECE**
 5, Mavrogenous Str.
GR-18542 Piraeus
 Phone: +30 10 / 42 10 050
 Fax: +30 10 / 42 12 033
 e mail: —

Meltrade Automatika Kft. **HUNGARY**
 55, Harmat St.
HU-1105 Budapest
 Phone: +36 (0)1 / 2605 602
 Fax: +36 (0)1 / 2605 602
 e mail: office@meltrade.hu

MITSUBISHI ELECTRIC EUROPE B.V. – Irish Branch **IRELAND**
 Westgate Business Park
IRL-Dublin 24
 Phone: +353 (0) 1 / 419 88 00
 Fax: +353 (0) 1 / 419 88 90
 e mail: sales.info@meuk.mee.com

EUROPEAN REPRESENTATIVES

POWEL SIA **LETLAND**
 Lienes iela 28
LV-1009 Riga
 Phone: +371 784 / 22 80
 Fax: +371 784 / 22 81
 e mail: utu@utu.lv

UTU POWEL UAB **LITHUANIA**
 Savanoriu pr. 187
LT-2053 Vilnius
 Phone: +370 23 22 980
 Fax: +370 23 22 980
 e mail: utu@utu.lt

Getronics b.v. **NETHERLANDS**
 Control Systems
 Donauweg 2 B
NL-1043 AJ Amsterdam
 Phone: +31 (0) 20 / 587 67 00
 Fax: +31 (0) 20 / 587 68 39
 e mail: info.gia@getronics.com

Beijer Electronics AS **NORWAY**
 Teglverksveien 1
N-3002 Drammen
 Phone: +47 (0) 32 / 24 30 00
 Fax: +47 (0) 32 / 84 85 77
 e mail: info@elc.beijer.no

MPL Technology SP. z.o.o. **POLAND**
 ul. Sliczna 36
PL-31-444 Kraków
 Phone: +48 (0) 12 / 632 28 85
 Fax: +48 (0) 12 / 632 47 82
 e mail: krakow@mpl.pl

Sirius **ROMANIA**
 Trading & Services srl
 Bd. Lacul Tei nr. 1 B
RO-72301 Bucuresti 2
 Phone: +40 (0) 1 / 201 7147
 Fax: +40 (0) 1 / 201 7148
 e mail: sirius_t_s@fx.ro

ACP AUTOCOMP a.s. **SLOVAKIA**
 Chalupkova 7
SK-81109 Bratislava
 Phone: +421 7 52 92 22 54
 Fax: +421 7 52 92 22 48
 e mail: info@acp-autocomp.sk

INEA d.o.o. **SLOVENIA**
 Stegne 11
SI-1000 Ljubljana
 Phone: +386 (0) 1-513 8100
 Fax: +386 (0) 1-513 8170
 e mail: inea@inea.si

Beijer Electronics AB **SWEDEN**
 Box 426
S-20124 Malmö
 Phone: +46 (0) 40 / 35 86 00
 Fax: +46 (0) 40 / 93 23 02
 e mail: info@beijer.se

ECONOTEC AG **SWITZERLAND**
 Postfach 282
CH-8309 Nürensdorf
 Phone: +41 (0) 1 / 838 48 11
 Fax: +41 (0) 1 / 838 48 12
 e mail: info@econotec.ch

GTS **TURKEY**
 Darülaceze Cad. No. 43A KAT: 2
TR-80270 Okmeydani-Istanbul
 Phone: +90 (0) 212 / 320 1640
 Fax: +90 (0) 212 / 320 1649
 e mail: gts@turk.net

MIDDLE EAST REPRESENTATIVES

TEXEL Electronics Ltd. **ISRAEL**
 PO Box 6272
IL-Netanya 42160
 Phone: +972 (0) 9 / 863 08 91
 Fax: +972 (0) 9 / 885 24 30
 e mail: texel_me@netvsion.net.il

ILAN & GAVISH LTD **ISRAEL**
 24 Shenkar St., Kiryat Arie
IL-49001 Petach-Tikva
 Phone: +972 (0) 3 / 922 18 24
 Fax: +972 (0) 3 / 972 39 24 07 61
 e mail: iandg@internet-zahav.net

EURASIAN REPRESENTATIVES

AVTOMATIKA SEVER **RUSSIA**
 Krapiwnij Per. 5, Of. 402
RUS-194044 St Petersburg
 Phone: +7 812 54 18 418
 Fax: +7 812 11 83 239
 e mail: —

CONSYS **RUSSIA**
 Promyshlennaya St. 42
RUS-198099 St Petersburg
 Phone: +7 812 / 325 36 53
 Fax: +7 812 / 325 36 53
 e mail: consys@consys.spb.ru

ICOS **RUSSIA**
 Industrial Computer Systems Zao
 Ryazanskij Prospekt 8a, Office 100
RUS-109428 Moscow
 Phone: +7 095 / 232 - 0207
 Fax: +7 095 / 232 - 0327
 e mail: mail@icos.ru

NPP Uralelektra **RUSSIA**
 Sverdlova 11A
RUS-620027 Ekaterinburg
 Phone: +7 34 32 / 53 27 45
 Fax: +7 34 32 / 53 24 61
 e mail: elektra@etel.ru

STC Drive Technique **RUSSIA**
 Poslannikov per., 9, str.1
RUS-107005 Moscow
 Phone: +7 095 / 786 21 00
 Fax: +7 095 / 786 21 01
 e mail: info@privod.ru

JV-CSC Automation **UKRAINE**
 15, Marina Raskovoyi St.
U-02002 Kiev
 Phone: +380 44 / 238 83 16
 Fax: +380 44 / 238 83 17
 e mail: mkl@csc-a.kiev.ua

TEHNIKON **BELARUS**
 Oktjabrskaya 16/5, Ap 704
BY-220030 Minsk
 Phone: +375 (0)17/ 22 75 704
 Fax: +375 (0)17/ 22 76 669
 e mail: tehnikon@belsonet.net

AFRICAN REPRESENTATIVE

CBI Ltd **SOUTH AFRICA**
 Private Bag 2016
ZA-1600 Isando
 Phone: +27 (0) 11/ 928 2000
 Fax: +27 (0) 11/ 392 2354
 e mail: cbi@cbi.co.za