



KONICA MINOLTA



# VIVID 9i

NON-CONTACT 3D DIGITIZER

**VIVID 9i, the most accurate VIVID yet**

Introducing the latest addition to Konica Minolta's VIVID Series.

**Featuring improved accuracy and usability and flexibility.  
Offering unprecedented value.**

It's the most advanced model for industrial applications from reverse engineering to design verification and dimensional inspection.



The essentials of imaging

# Digital Process Re-engineering

Introducing the VIVID 9i non-contact 3D digitizer. This innovative device is ideal for reverse engineering, design verification, quality inspection, and other industrial applications.

The VIVID 9i non-contact 3D digitizer provides high-speed and high-accuracy 3D measurement of dies, cast and forged products, and stamped and plastic-molded products. The 9i excels at shape evaluation, tool and die qualification, and quality inspection during prototype creation and the during the production processes. The 9i is an ideal way to capture the shape and dimensional data of design models and prototypes in design drawings for reverse engineering purposes.

When used for reverse engineering or CAE, the VIVID 9i easily and accurately converts the shape of a product into 3D digital data. Using the VIVID 9i for inspection or CAT contributes to the early detection of shape problems, provides rapid feedback on design, and eliminates unnecessary work in downstream processes. As a result, it accelerates the entire manufacturing process.

Smooth input and output of 3D digital data are essential to increasing work efficiency during the design, manufacturing, and inspection processes. By introducing the VIVID 9i, Konica Minolta has accelerated the revolution in manufacturing - a sector committed to the use of digital processing tools such as CAD, CAM, and CAE, to higher-quality shape input and process output, and to reduced throughput time. That's why we're promoting "Digital Process Re-engineering," with the goal of improved efficiency, and ultimately of enhanced customer satisfaction.

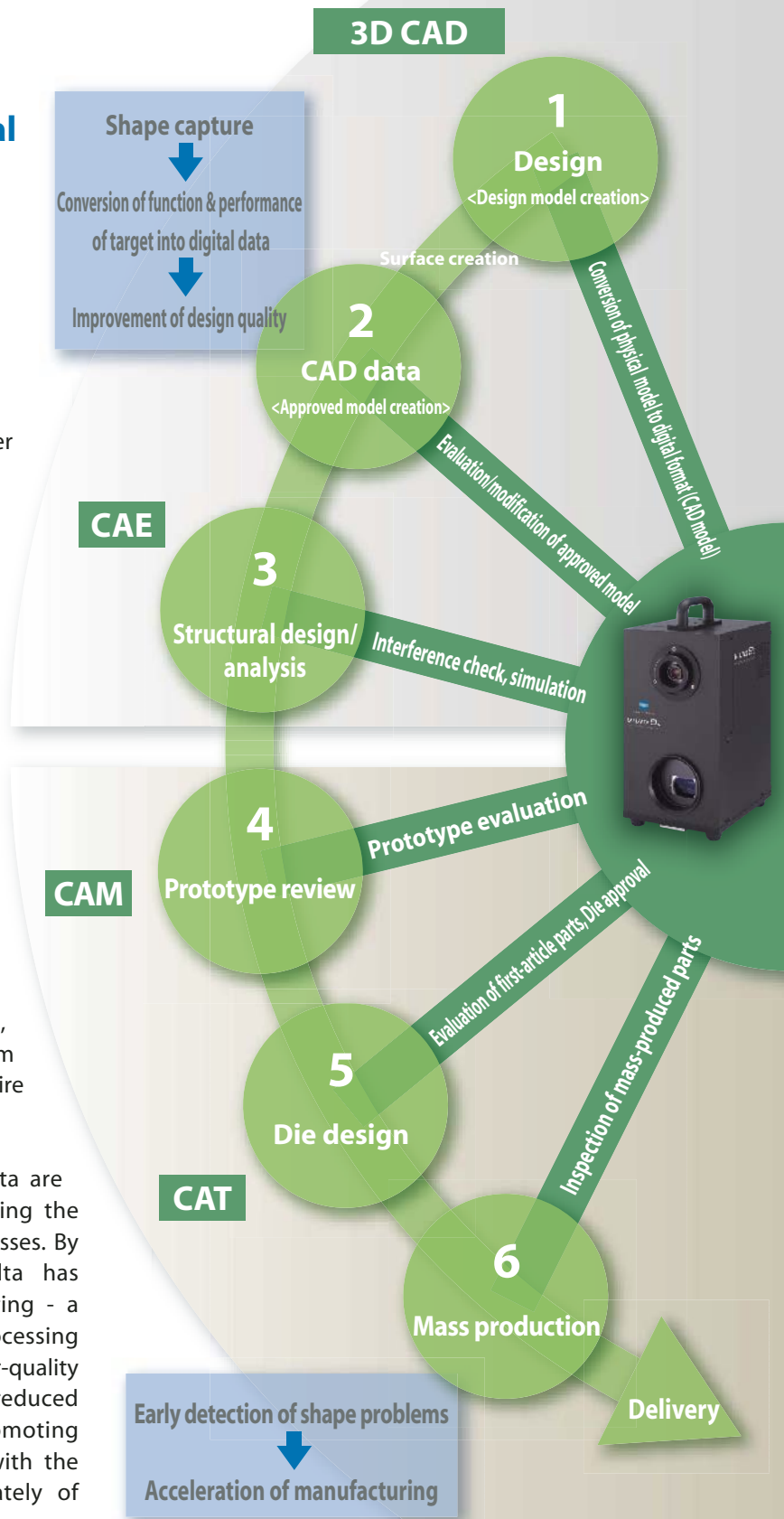

# VIVID 9i system

## VIVID 9i (Polygon Editing Tool Ver.2.0)

### Measure targets of any size.

Konica Minolta employed its expertise in optical engineering to develop interchangeable high-performance, dedicated lenses. As a result, TELE, MIDDLE and WIDE lenses can be selected to accommodate the size of the measurement target.

(Input range in X, Y and Z directions: 93 x 69 x 26 mm to 1495 x 1121 x 1750 mm)

### Point & Shoot, Leave detailed settings to the 9i.

Konica Minolta's AF/AE technology, developed through its expertise in camera manufacturing, relieves users from the need to determine the exact measuring distance. Moreover, the system automatically determines the optimum laser power for the surface conditions of the target.

(Scan Range : standard mode 0.6 to 1.0 m, Extended mode 0.5 to 2.5 m )



## 1 Scanning the target with a laser beam

Take a measurement with the , Polygon Editing Tool (ver. 2.0 bundled) software.

### High speed and high accuracy

Start the measurement by framing the scan area on the LCD Viewfinder of the VIVID 9i unit or on the host computer's display . Each scan requires only 2.5 seconds to acquire accurate 3D data.

### Standards-Traceable performance

Konica Minolta supports compliance with ISO 9000. Manufacturers using VIVID 9i for QC applications can receive test report of the accuracy of each 9i, traceable to national standard. Thereby ensuring that our measuring instruments and your process conform to ISO 9000 requirements.

\*On request, Konica Minolta can provide a test report for each 9i unit. This test report is created by evaluating the measurement accuracy for all 3 lenses of each 9i using our Reference 3D Chart, an artifact traceable to national standards, and thus can be used as documentation for conformance with ISO requirements.



Measurement with VIVID 9i

## 2 Merging and editing of 3D data

### Quick, easy editing

Missed a spot? You'll see it immediately and be able to scan any voids. You can check the measured 3D data in real time on the preview screen. This allows for sequential framing, measurement, and alignment of the data. Thanks to the improved processing speed and the new graphical user interface specifically developed for the VIVID 9i, even large amounts of measurement data can be merged, edited and converted into general 3D data format with greater speed and ease.

### Aluminum Wheel

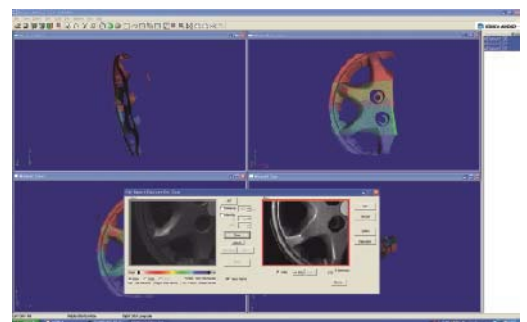

Measurement and data position alignment

What's more, our new field calibration system maintains the high reliability of the factory settings by canceling the degraded accuracy caused by lens exchange or a change in environment.

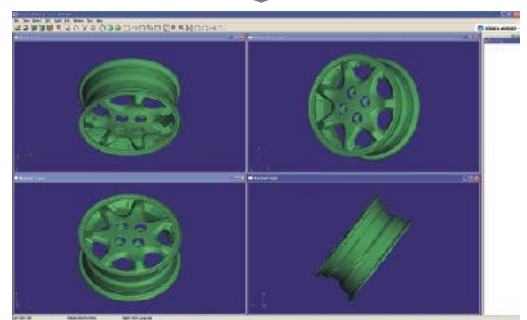

Merging of 3D data (polygons)

# Photogrammetry System PSC-1 optional

VIVID 9i captures large parts (> 1 meter) easily. When PSC-1 is used with the 9i, the combination enables the user to capture both high-detail and large parts. In the past, the alignment of multiple scans was error prone, making it hard to achieve high-detail and high accuracy on large parts. P-N automates the registration process, and removes the tolerance stack-up inherent in best-fit techniques.

When measuring a large part maximum detail is achieved by dividing the part into several scanned regions. With PSC-1 the individual scans are aligned (registered) automatically, with higher alignment accuracy than has been possible before. The procedure is described below:

## 1 Capture the image with a digital camera

The user will place scale bars around the object to be scanned (the "subject") and attach reference markers to the subject. With the dedicated digital SLR, the operator takes pictures of the subject, being sure to include both the coded markers and dimension-controlled scale bars. Based on these pictures, the coordinates of the reference markers are determined with high accuracy using photogrammetric technology, creating a sparse point cloud of the subject (i.e., a 3D "Constellation" in the shape of the subject).



PSC-1 Photographing scenario

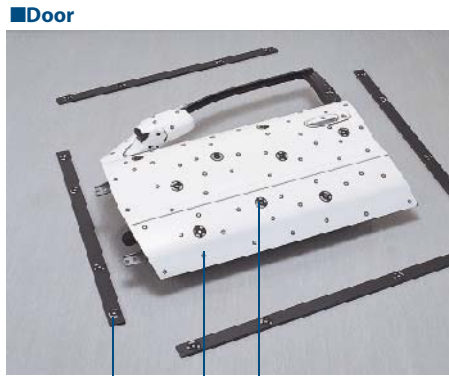

Door

Scale bar

Reference marker

Coded marker

VIVID 9i Measuring area

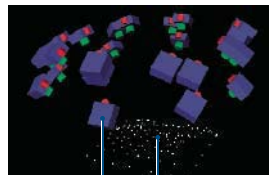
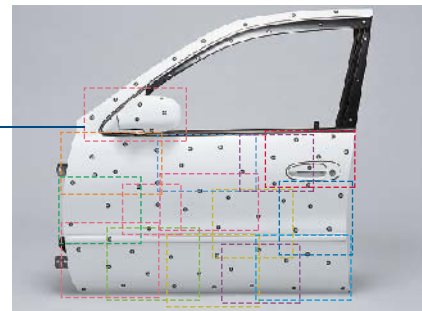

Positions of digital camera photos  
3D data of reference markers

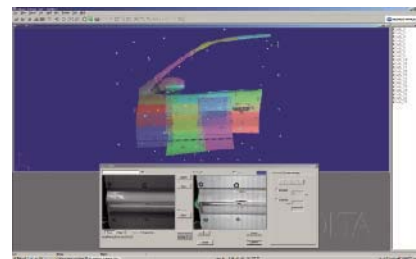

## 2 Automatic alignment and merging of 3D data

Now it's time to scan the surface detail using the 9i. As each VIVID 9i scan is captured, it is automatically aligned to the PSC-1 data cloud created in step 1. The VIVID 9i reads the target data and places the scans in their correct orientation. Even relatively smooth shapes such as fenders or door skins are accurately aligned because the alignment does not depend on complex surface geometry. Result: a more accurate model.

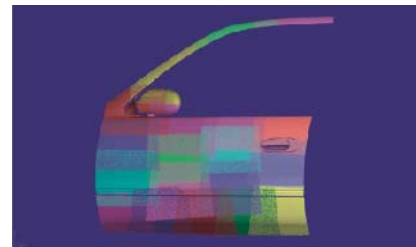

In addition to being more accurate, PSC-1 saves time. Firstly, any voids are apparent immediately; aligned data enables the user to scan any missing surface data. Secondly, since the scans are aligned to the photogrammetric point cloud (rather than to each other), there is no need to overlap scans. Furthermore, if two areas of interest are separated by an unimportant area, the operator no longer needs to scan the intervening area, saving more time.



Example of procedure for CAD data creation — Creation of a CAD Model of an automotive alum

Measured data (polygon) ■ Engine valve cover



Measurement, alignment, merging, hole filling, and cleaning

STL

Various analysis software/Rapid prototyping

Creating curves

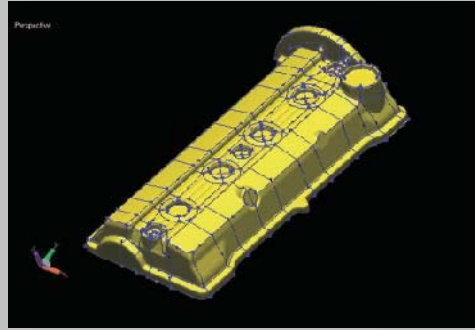

Manual curve creation

Unnecessary when the automatic surface creation function is used

Creating NURBS

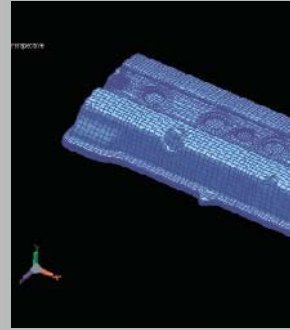

Creates a NURBS patch matching

Example of measured data

■ Instrument panel

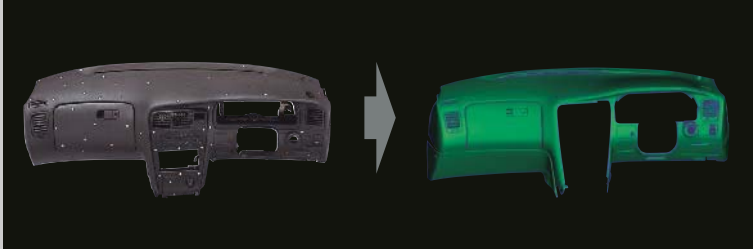

■ Bumper



Example of CAT work procedure — Comparison inspection between measured data and CAD

Scanning the sample

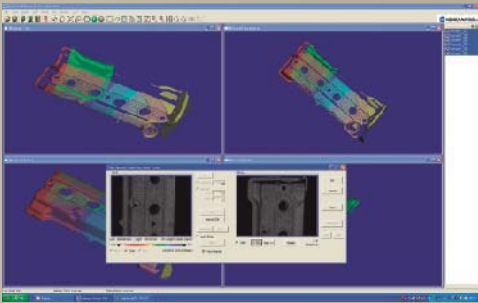

Measured data (polygon)

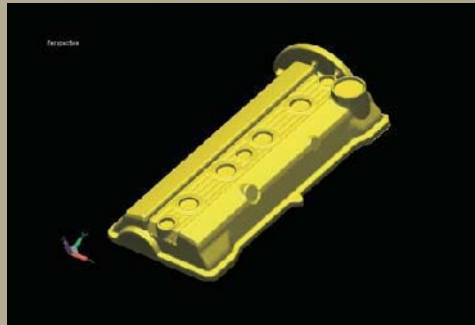

Measurement, alignment, merging, and cleaning

Importing CAD data

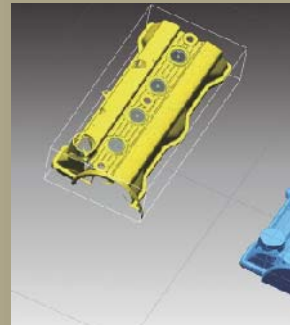

Example of inspection evaluation report — Comparison between reference CAD (NURBS) data and measured

Evaluation at cross section

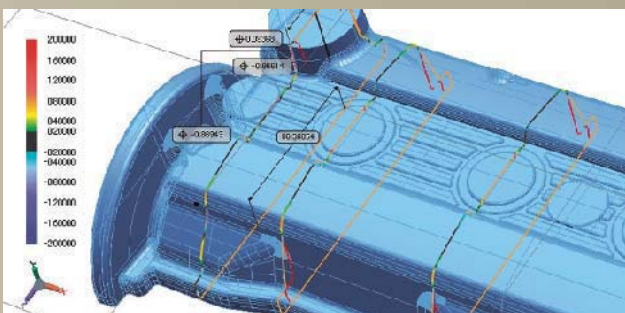

Early detection of shape problems

Cross section/Grid display/Diagram dimensions/Errors at specific

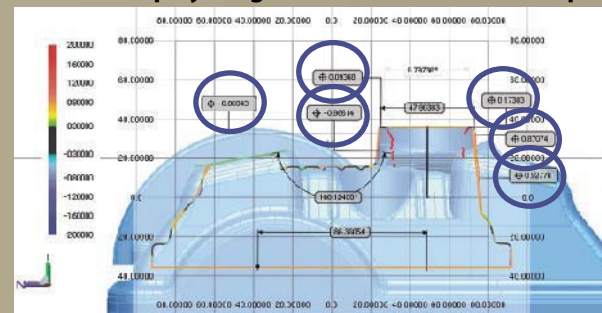

## Reverse aluminum casting

NURBS

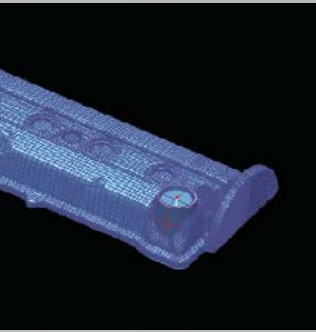

Match matching the curve boundaries

Trimmed NURBS surfaces

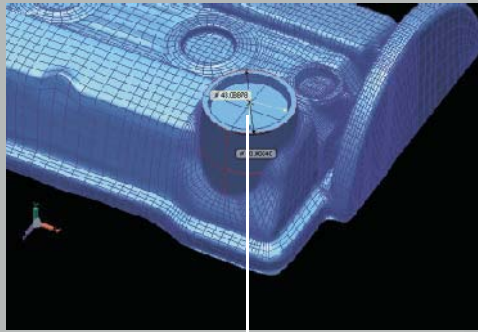

Create geometrically shaped surfaces such as cones and planes. Trim the data with these surfaces.

High-continuity surface data

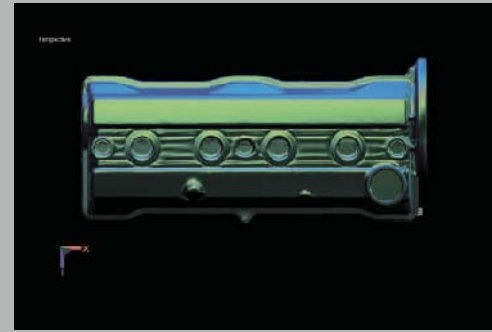

Example of continuous surface evaluation using environment mapping

3D  
CAD  
IGES

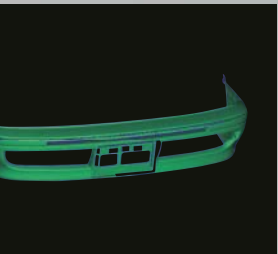

### Major applications

- Automotive/motorcycle manufacturers and parts maker
- Dimensional inspection of cast/forged parts. Checking of the margin remaining for secondary processing
- Accuracy inspection, parts inspection, interference check with mechanical parts, die verification of press- or plastic-molded products
- Inspection/analysis of car seats, tires, and cushioning materials
- Reverse engineering using actual objects, mock-ups, and scale models of car seats, headrests or wheels

- Companies in heavy industry, iron/steel or heavy equipment manufacturers
    - Inspection of turbine blades, steel pipes and steel plates. Design of heavy equipment
  - Other manufacturers
    - Inspection or reverse engineering of interior/exterior wall materials and modular bath units
    - Inspection of train rail wear, tanks at hydroelectric power plants, and turbine blades
- For other applications, visit our website below

<http://www.minolta3d.com>

## and CAD data

3D data

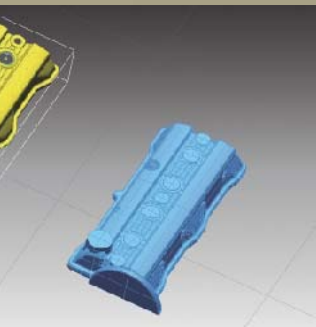

Alignment with CAD data

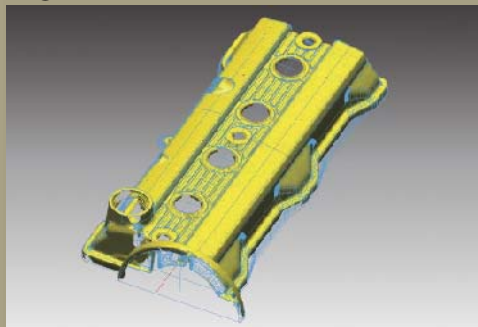

Color map calculation

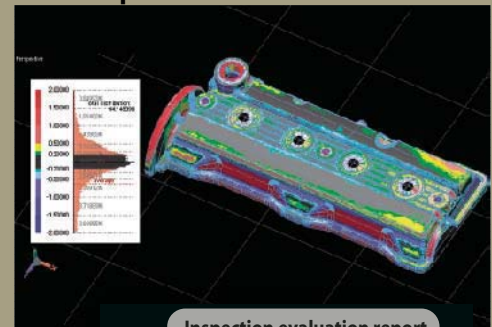

Inspection evaluation report

Comparison between CAD data and measured data

Color map display providing at-a-glance indication of sections within/outside the tolerance range (contour display)

3D measured data

Measurements at specific points

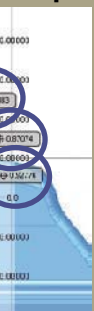

# The non-contact 3D digitizer VIVID 9i offers improved accuracy and ease of use.

## High speed, high precision, and Measurement accuracy of $\pm 50\mu\text{m}$

The VIVID 9i requires only 2.5 seconds per scan to acquire accurate 3D data.

Consequently, the VIVID 9i is ideal for accuracy verification and shape inspection of cast, forged, and pressed automotive parts and plastic-molded automotive parts. Give us your part, and we'll prove it to you.

The new Field Calibration system, negates inaccuracies caused by lens exchange or environmental changes. A simple calibration procedure before use assures the optimal performance from the 9i.

## High-accuracy measurement of even large parts

The VIVID 9i can be combined with PSC-1, Konica Minolta's optional photogrammetry system. The combination of the VIVID 9i and PSC-1 provides for fast and accurate measurement and data assembly even for relatively large targets - such as car body portions, doors, bumpers, and instrument panels. It is also effective to correctly align surfaces having no characteristic shape, such as projections and depressions. (Typical subject size ranges from 0.5 to 2.0 m and larger)

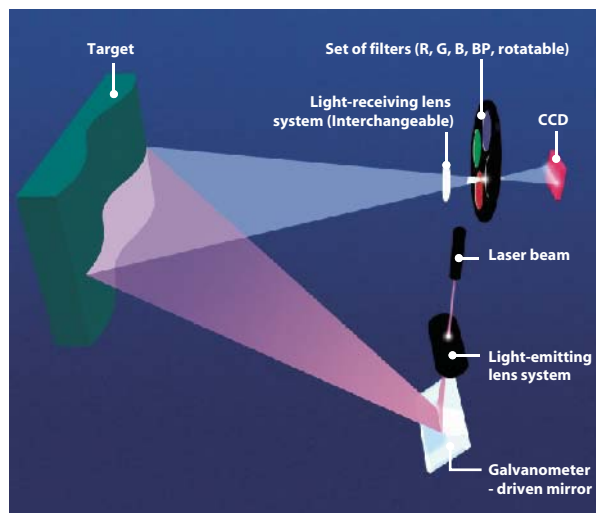

### <Measurement principle>

The VIVID 9i is based on the principal of laser triangulation. A target is scanned with laser stripes. The CCD camera receives the light reflected from the surface of the subject. Surface shape measurements of the subject are obtained through triangulation, and converted into a 3D polygon mesh. The VIVID 9i measures 640 x 480 points with one scan, simultaneously acquiring surface shape data and color image data.

## VIVID 9i system

### VIVID 9i (Polygon Editing Tool Ver.2.0)



#### < VIVID 9i Main standard accessories >

- ① Interchangeable Lenses (TELE, MIDDLE, WIDE)
- ② Field Calibration System
  - Polygon editing software "Polygon Editing Tool ver.2.0"
  - SCSI Cable

#### <Optional accessories>

- ③ Tripod Set
  - Rotating Stage Set



\* Shape varies with sales region.

VIVID 9i System configuration

## Photogrammetry System PSC-1 optional



- ① Digital SLR Camera(14 megapixel)
- ② Ring Flash
- ③ Scale Bar Set
- ④ Camera Calibration System
- ⑤ Reference Marker Set
- ⑥ Coded Marker Set
  - Compact Flash Card
  - Photogrammetry software Photo Modeler KM

PSC-1 System configuration

## Specifications of VIVID 9i

<b>Type</b>	Non-contact 3D digitizer
<b>Measuring Method</b>	Triangulation light block method
<b>Light-Receiving Lenses (Interchangeable)</b>	<b>TELE</b> Focal distance f=25 mm <b>MIDDLE</b> Focal distance f=14 mm <b>WIDE</b> Focal distance f=8 mm
<b>Scan Range</b>	0.6 to 1.0 m (In Standard mode) 0.5 to 2.5 m (In Extended mode)
<b>Laser Scan Method</b>	Galvanometer-driven rotating mirror
<b>Laser Class</b>	Class 2 (IEC60825-1), Class 1 (FDA)
<b>X Direction Input Range(In Extended mode)</b>	<b>TELE</b> 93 to 463 mm <b>MIDDLE</b> 165 to 823 mm <b>WIDE</b> 299 to 1495 mm
<b>Y Direction Input Range(In Extended mode)</b>	<b>TELE</b> 69 to 347 mm <b>MIDDLE</b> 124 to 618 mm <b>WIDE</b> 224 to 1121 mm
<b>Z Direction Input Range(In Extended mode)</b>	<b>TELE</b> 26 to 680 mm <b>MIDDLE</b> 42 to 1100 mm <b>WIDE</b> 66 to 1750 mm
<b>Accuracy (X, Y, Z)</b>	±0.05 mm (Using TELE lens at distance of 0.6 m, with Field Calibration System, Konica Minolta's standard, at 20°C)
<b>Precision (Z, σ)</b>	0.008 mm (Using TELE lens at distance of 0.6 m, Konica Minolta's standard, at 20°C)
<b>Input Time (per scan)</b>	2.5 sec
<b>Transfer Time to Host Computer</b>	Approx. 1.5 sec
<b>Ambient Lighting Condition</b>	Office environment, 500 lx or less
<b>Imaging Element</b>	3D data: 1/3-inch frame transfer CCD (340,000 pixels) Color data: Common with 3D data (color separation by rotary filter)
<b>Number of Output Pixels</b>	3D data/Color data: 640 x 480
<b>Output Format</b>	3D data: Konica Minolta format, & (STL, DXF, OBJ, ASCII points, VRML) (Converted to 3D data by the Polygon Editing Software/ standard accessory) Color data: RGB 24-bit raster scan data
<b>Data File Size</b>	Total 3D and color data capacity: 3.6MB per data
<b>Viewfinder</b>	5.7-inch LCD (320 x 240 pixels)
<b>Output Interface</b>	SCSI II (DMA synchronous transfer)
<b>Power</b>	Commercial AC power, 100 to 240 V (50/60Hz), rated current 0.6 A (at 100 VAC)
<b>Dimensions</b>	221 (W) x 412 (H) x 282 (D) mm
<b>Weight</b>	Approx. 15 kg (with lens attached)
<b>Operating temperature/humidity range</b>	10°C to 40°C, relative humidity 65% or less with no condensation
<b>Storage temperature/humidity range</b>	0°C to 40°C, relative humidity 85% or less (at 35°C) with no condensation
<b>Regulatory approvals</b>	UL 61010A-1, CSA-C22.2 No.1010-1, etc.



## Specifications of Polygon Editing Tool ver. 2.0

<b>&lt;Main Features&gt;</b>		<b>&lt;Operating Environment&gt;</b>	
<b>Readable Formats</b>	Konica Minolta proprietary formats: CAM, VVD, SCN, CDM, CDK General format: STL	<b>PC-AT compatible OS</b>	Computer running Windows®2000/Windows®XP Windows®2000 Professional (Service Pack 2 or higher) Windows®XP Professional (Service Pack 1 or higher)
<b>Data Conversion</b>	Conversion from Konica Minolta proprietary formats into general format Polygonal data: DXF, Wavefront, Softimage, VRML 2.0, STL, MGF Point group data: ASCII	<b>CPU</b>	Pentium III or better
<b>Functions</b>	Data alignment, data merging, smoothing, uniform data reduction, adaptive data reduction, polygon check, texture blending Rotation, movement, deletion, hole filling with data interpolation	<b>RAM</b>	512 MB (1024 MB recommended)
<b>Point Group Editing</b>		<b>Display</b>	Graphic display ability at 1024 x 768 or more
<b>Camera Remote Operation</b>	Measurement, measurement reference distance setting, number of scans setting, laser power setting, high-quality setting, filter setting, etc.	<b>Graphics Board</b>	OpenGL-ready board (verified-compatible board recommended.)
<b>Display Modes</b>	Wireframe, shading, texture mapping	<b>SCSI Interface</b>	Adaptec SCSI card (Please use a verified compatible board.)
		<b>Others</b>	CD-ROM drive, USB port

For further information regarding graphics board and SCSI interface, please contact the Vivid Salesperson in your area.

## Specifications of Photogrammetry System PSC-1

<b>Typical Subject Size</b>	0.5 to 2.0 m
<b>Accuracy</b>	±0.1 mm for volume <2 m <sup>3</sup> and below (Measurement subject size : 1 m, Photogrammetry alone, Konica Minolta's standard, at 20°C)

- Specifications are subject to change without notice.
- Product names in this brochure are trademarks of their respective companies.

<p><b>SAFETY PRECAUTIONS</b></p> <p>Read all safety and operating instructions before operating the VIVID 9i.</p> <ul style="list-style-type: none"> <li>● Use only a power source of the specified rating. Improper connection may cause a fire or electric shock.</li> <li>● Do not stare into the laser beam. (MAX. 30mW 690nm / CLASS 1 (FDA), CLASS 2 (IEC) LASER PRODUCT)</li> </ul>		<p>The manufacturing center of Konica Minolta Sensing Inc. (Location: Aichi Pref., Japan) was approved by the British certification organization Lloyd's Register Quality Assurance for certification under the ISO 9001: 1994 international quality management system standards on March 3, 1995. Since its establishment in 1990, the center has carried out the development and production of precision instruments and associated application software for the measurement of color, light, and shape. Certification was awarded to the center's quality management system, including design, manufacturer, management of manufacture, calibration and servicing. Certification was carried over to the ISO 9001: 2000 standards in February, 2003.</p>
--	--	---

KONICA MINOLTA SENSING, INC.

3-91, Daisennishimachi, Sakai. Osaka 590-8551, Japan

E-Mail : [3dinfo@konicaminolta.jp](mailto:3dinfo@konicaminolta.jp)  
Web : [http://konicaminolta.jp/pr/se\\_3d](http://konicaminolta.jp/pr/se_3d)

Konica Minolta Photo Imaging U.S.A., Inc.

725 Darlington Avenue, Mahwah, NJ 07430, U.S.A. Phone: 888-473-2656 (in USA), 201-574-4000 (outside USA) FAX: 201-574-4201

E-Mail : [VIVID3d@minolta.com](mailto:VIVID3d@minolta.com)  
Web : [www.minolta3d.com](http://www.minolta3d.com)

Konica Minolta Photo Imaging (HK) Ltd.  
Konica Minolta Photo Imaging Asia HQ Pte Ltd.

Room 1818, Sun Hung Kai Centre, 30 Harbour Road, Wanchai, Hong Kong Phone: 852-34137508 FAX: 852-34137509  
10, Teban Gardens Crescent, Singapore 608923 Phone: +65 6563-5533 FAX: +65 6560-9721