

PRICE LIST

**STOCK RANGE MINIATURE LOW VOLTAGE D.C. MOTORS & GEARBOX UNITS
BATTERIES & CHARGERS.**

GEARBOXES (Including motor)
(This list indicates ex-stock ratios)

917D	£4.25 ea.
917D/A	£5.95 ea.
918D151	£8.47 ea.
918D151/1	£8.47 ea.
918D15112	£9.32 ea.
918D15112/1	£9.32 ea.
918D1001/1	£8.47 ea.
918D100112/1	£9.32 ea.
918D10241/1	£9.50 ea.
918D2501/1	£8.94 ea.
918D250112/1	£9.32 ea.
918D301/1	£8.47 ea.
918D30112/1	£9.32 ea.
919D24	£16.98 ea.
919D2.51	£16.11 ea.
919D61	£16.13 ea.
919D111	£16.13 ea.
919D501	£16.13 ea.
919D1001	£16.13 ea.
919D1481	£16.13 ea.
919D5001	£18.71 ea.
919D8101	£18.71 ea.
919D30001	£20.91 ea.
920D	£6.77 ea.
920D/A	£7.62 ea.
927D	£7.62 ea.
927D/A	£8.47 ea.
940D51	£16.83 ea.
940D1001	£22.92 ea.
940D5161	£26.52 ea.
941D41	£11.40 ea.
941D621	£15.84 ea.
941D1041	£15.84 ea.
941D10141	£20.73 ea.
941D2311	£18.51 ea.
942D51	£18.53 ea.
942D1001	£24.62 ea.
942D5161	£28.22 ea.
944D41	£11.95 ea.
944D621	£16.34 ea.
944D1041	£16.34 ea.
944D2311	£19.01 ea.
950D2.51	£14.63 ea.
950D61	£14.63 ea.
950D111	£14.63 ea.
950D501	£14.63 ea.
950D1001	£14.63 ea.
950D1481	£14.63 ea.
950D8101	£17.21 ea.
950D30001	£19.41 ea.
960D211	£51.02 ea.
965D211	£51.02 ea.
966D211	£34.00 ea.
970D61	£21-13 ea.
970D161	£21-13 ea.
970D471	£21-13 ea.
970D1561	£21-13 ea.
970D7501	£23-71 ea.
970D28121	£25-91 ea.
975D41	£29-58 ea.
975D1041	£35-43 ea.
975D5041	£37-80 ea.

GEARBOXES (Including motor)
(This list indicates ex-stock ratios)

980D61	£19.63 ea.
980D161	£19.63 ea.
980D471	£19.63 ea.
980D1561	£19.63 ea.
980D7501	£22-21 ea.
980D28121	£24-41 ea.
986D41	£69.83 ea.
986D1001	£82-50 ea.
986D4881	£89-58 ea.
990D41	£21-80 ea.
990D641	£28-83 ea.
990D2561	£32-72 ea.
995D41	£106-52 ea.
995D1001	£120-51 ea.
995D4881	£128-30 ea.

MOTORS WITH BRACKETS (Motor Mounts).

Part No.	
457 RE 140	£2.45 ea.
457 RE 140/1	£2.64 ea.
457 RE 260	£2-53 ea.
457 RE 280	£2.97 ea.
457 RE 280/1	£3.94 ea.
457 RE 360	£4.82 ea.
457 RE 360/1	£
457 RE 380	£5.27 ea.
457 RE 385	£5.47 ea.
457 RE 540	£6.87 ea.
457 RE 540/1	£7.44 ea.
457 RE 550/1	£7.23 ea.
457 RE 800	£21.14 ea.
457 RE 850	£21.14 ea.

MOTORS WITHOUT BRACKETS (Motor Mounts).

Part No.	
719 RE 140	£1.09 ea.
719 RE 140/1	£1.28 ea.
719 RE 260	£1-61 ea.
719 RE 280	£1.61 ea.
719 RE 280/1	£2.57 ea.
719 RE 360	£3.38 ea.
719 RE 360/1	£
719 RE 380	£3.82 ea.
719 RE 385	£4.02 ea.
719 RE 540	£5.39 ea.
719 RE 540/1	£5.95 ea.
719 RE 550/1	£5.74 ea.
719 RE 700	£29.78 ea.
719 RE 800	£19.23 ea.
719 RE 850	£19.23 ea.
719 RE 900	T.B.A.

NOTE:
Motors with 457 pre-fix = with brackets (Motor Mounts).
Motors with 719 pre-fix = without brackets (Motor Mounts).

SPEED REGULATORS.

Part No.	
919D2	£9.79 ea.
919D2/P	£11.87 ea.

THUNDERBOLT LAMP

Part No.	
1122	£110-61 ea.

HEADLAMP

Part No.	
1077/27	£16.98 ea.
1077MK3COMP	£51.02 ea.
1077/30	£34.01 ea.
1077MK4COMP	£55.28 ea.
1158	£14.46 ea.

DRILL KIT

Part No.	
399DPLUS	£34.00 ea.

SOLAR PRODUCTS

Part No.	
SP10	£POA
SP30	£POA
SPM149	£POA
Max discount available 33.33%	

BATTERIES

Part No.	
177 6v 4Ah	£8.00 ea.
178 2v 10Ah	£8.11 ea.
629 6v 3Ah	£15.28 ea.
887 12v 3Ah	£16.13 ea.
1084 12v 1.9Ah	£13.33 ea.
1095 12v 1.2Ah	£10.89 ea.
1113 12v 7Ah	£16.13 ea.
1153 6v 12Ah	£16.14 ea.
1119 12v 12Ah	£29.75 ea.

BATTERY CHARGERS.

Part No.	
229	£22.09 ea.
827	£8.47 ea.
1077/5MOD	£7.62 ea.

**TRANSFORMERS.
(VARIABLE SPEED)**

Part No.	
400D	£34.01 ea.
400DHD	£37.50 ea.

ALL MAJOR CREDIT/DEBIT CARDS ACCEPTED.
(Regret not American Express or Diners Club)

All the above prices are subject to VAT.

QUANTITY DISCOUNTS.

Order value up to £150 excluding VAT	NIL
" " £151 - £1999	less 33.33%
" " £2000 +	less 50%

PLEASE NOTE: All dimensions & specifications are issued for guidance only and are not intended to constitute any contractual obligation on the part of MFA/Como Drills. MFA/COMO DRILLS reserve the right to alter prices and specifications without prior notice.

NOTE: O.E.M. CUSTOMERS ONLY.

SUBJECT TO SIGNED EXEMPTION CERTIFICATE THESE MOTORS CAN BE SUPPLIED UN-SUPPRESSED. (P.O.A.)

MULTI RATIO GEARBOX - DESIGNED FOR EDUCATIONAL USE

**MULTI RATIO GEARBOX.
IDEAL FOR CDT
(CRAFT, DESIGN AND
TECHNOLOGY)**

- 917D KIT FORM (RE 140 MOTOR)
- 917D/A ASSEMBLED VERSION (RE 140 MOTOR)
- 920D KIT FORM (RE 280 MOTOR)
- 920D/A ASSEMBLED VERSION (RE 280 MOTOR)
- 927D KIT FORM (RE 280/1 MOTOR)
- 927D/A ASSEMBLED VERSION (RE 280/1 MOTOR)

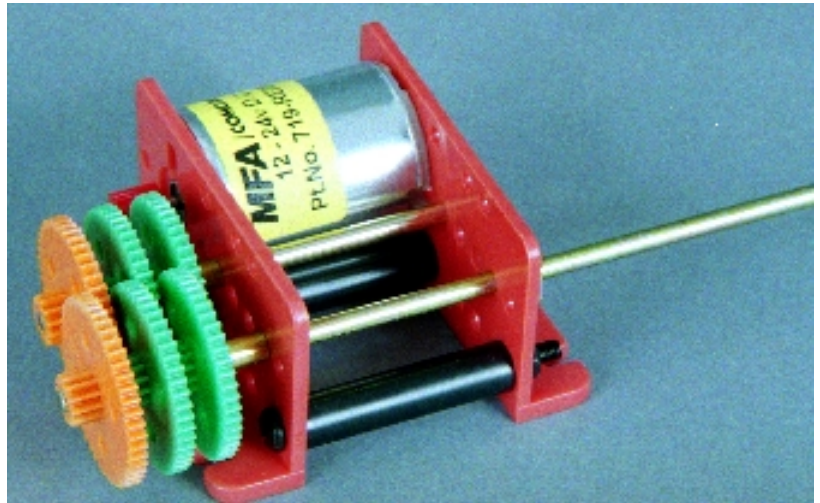

*** PROVIDES 6 DIFFERENT RATIOS AND 18 SPEEDS.* RUGGED AND COMPACT DESIGN AND CONSTRUCTION.* IDEAL FOR MODELS, CDT (CRAFT, DESIGN AND TECHNOLOGY) PROJECTS.* OPERATES FROM 1.5 - 3v (RE140 &, WITH THE HIGHER TORQUE MOTOR, RE280) AND 12 - 24v (RE280/1) D.C. SUPPLIES. * EXTENSIVE RANGE OF ACCESSORIES AVAILABLE.**

The unit operates on 1.5 - 3v (917D & 917D/A, also with higher torque motor 920D & 920D/A), or 12-24v (927D & 927D/A) D.C. power sources, either battery or suitable transformer. Its simple versatile design and sturdy construction make it suitable for a host of uses from powering models and robots to teaching the principles of mechanics. Current consumption depends on eventual load but is within the range 0.2 to 0.8n amps. The output shaft is 3mm diameter.

GEARBOX DIMENSIONS.

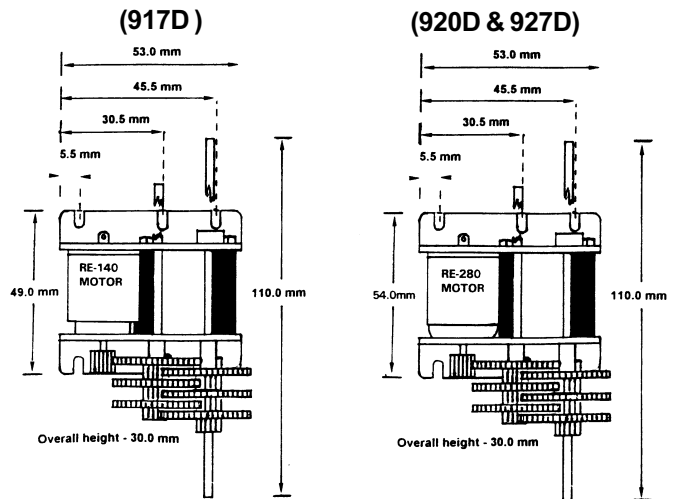

IMPORTANT NOTICE

Due to the wide range of applications for this product it is the users responsibility to establish the products suitability for their individual purpose(s).

WEIGHT	
917D	54g
920D	76g
927D	76g

MOTOR DATA. (RE-140, RE-280 & RE-280/1)

MODEL	VOLTAGE		NO LOAD		AT MAXIMUM EFFICIENCY						STALL TORQUE	
	OPERATING RANGE	NOMINAL	SPEED	CURRENT	SPEED	CURRENT	TORQUE		OUTPUT	EFF	STALL TORQUE	
			R.P.M.	A	R.P.M.	A	oz - in	g - cm	W	%	oz - in	g - cm
RE - 140	1.5 - 3.0	3.0v CONSTANT	14800	0.300	11500	1.05	0.152	10.92	1.29	41.03	0.68	49.0
RE - 280	1.5 - 3.0	1.5v CONSTANT	4600	0.120	3750	0.53	0.160	11.53	0.44	56.20	0.86	62.0
RE - 280	1.5 - 3.0	3.0v CONSTANT	9200	0.155	7800	0.85	0.278	20.00	1.60	62.30	1.81	130.0
RE - 280/1	12 - 24	12V CONSTANT	8400	0.100	6300	0.30	0.347	25.00	1.62	44.87	1.389	100.0

REDUCTION TABLE R.P.M. (917D)

	1.5V	3.0V
4:1	1850	3700
16:1	462	925
64:1	115	231
256:1	29	57
1024:1	7	14
4096:1	2	4

REDUCTION TABLE R.P.M. (920D)

	1.5V	3.0V
4:1	1150	2300
16:1	287	575
64:1	72	144
256:1	18	36
1024:1	4	9
4096:1	1	2

REDUCTION TABLE R.P.M. (927D)

	12V	15V	18V	24V
4:1	2100	2625	3150	4199
16:1	525	656	787	1050
64:1	131	164	196	261
256:1	33	42	50	67
1024:1	8	10	12	16
4096:1	2	2	3	4

MULTI RATIO GEARBOX

MULTI RATIO GEARBOX ACCESSORIES.
(917D, 917D/A, 920D, 920D/A, 927D, 927D/A.)

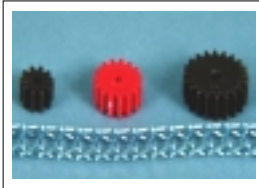

Pt.No.917D2401,2402,2403
2404,2449/1



Pt.No.917D2417,2458



Pt.No.917D2420



Pt.No. 917D2425

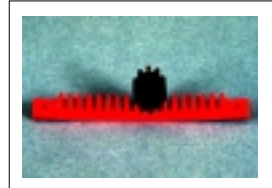

Pt.No. 917D2401
Pt.No. 917D2430
(Set: 917D/1)



Pt.No. 917D2440



Pt.No.917D2445,2446,2449



Pt.No.917D2452,2456

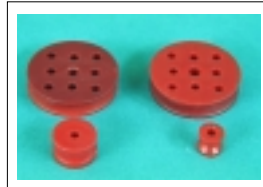

Pt.No.917D2460,2461,2462,2463

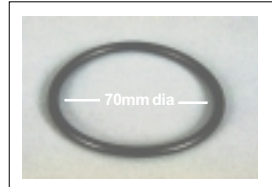

Pt.No.917D2515



Pt.No.917D2501,2502,2504,
2505,2506,2507,2509, 2513

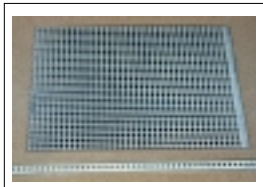

Pt.No.917D2531,2540



Pt.No.917D2551,2553

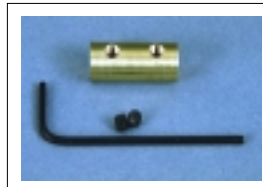

Pt.No. 917D8



Pt.No.917D9,D10,D11

- Part No. 917D8. Inline Coupling. 3mm - 3mm. (7.9mm x 20mm)
- Part No. 917D9. Voltage regulator. 6-15v DC Input.3v1.5amp output. (31mm x 26mm x 15.5mm)
- Part No. 917D10. Voltage regulator.6-15v DC Input. 1.5v,1.5amp output. (31mm x 26mm x 15.5mm)
- Part No. 917D11. Voltage regulator. 6-15v DC Input. 4.5v,1.5amp output. (31mm x 26mm x 15.5mm)
- Part No. 917D2401. Gear. 10 tooth. 2.9mm bore. (Dia. 11.2mm x 5.8mm)(pkt 10)
- Part No. 917D2402. Gear. 15 tooth. 2.9mm bore. (Dia. 16.2mm x 5.8mm)(pkt 10)
- Part No. 917D2403. Gear. 20 tooth. 2.9mm bore. (Dia. 22mm x 6.3mm)(pkt 10)
- Part No. 917D2404. Gear. 40 tooth. 2.9mm bore. (Dia. 41.3mm x 6.3mm)(pkt 10)
- Part No. 917D2415. Stop Rings.(pkt 10)
- Part No. 917D2417. Micro-Switch operating pins. (Dia. 3.9mm/5.7mm x 8mm)(pkt 10)
- Part No. 917D2420. Worm Drive. (Dia. 11.94mm x 32mm)(pkt 10)
- Part No. 917D2425. Custom gearbox bracket. (69.8mm x 27.9mm x 2.0mm)(pkt 2)
- Part No. 917D2426. Gearbox Brackets. (52.8mm x 30.0mm x 2.0mm)(pkt 2)
- Part No. 917D2430. Rack. (50.mm x 4.7mm x 5.13mm)(pkt 10)
- Part No. 917D2440. Crown Gear. (OD 16.4mm x 6.9mm high)(pkt 10)
- Part No. 917D2445. Chain Sprocket. 8 tooth 2.9mm bore. (OD 13.9mm)(pkt 10)
- Part No. 917D2446. Chain Sprocket.16 tooth 2.9mm bore. (OD 26.7mm)(pkt 10)
- Part No. 917D2449. Chain in 1m length approx. (7.1mm wide)
For gears 917D2445, 2446.
- Part No. 917D2449/1. Chain in 1m length approx. (10.8mm Wide)
For gears 917D2401,2402, 2403 & 2404.

- Part No. 917D2452. Double Gear. 48/12. 2.9mm bore. (OD24.57mm/OD6.72mm)(pkt 10)
- Part No. 917D2456. Double Gear. 48/12. 3.1mm bore. (OD24.57mm/OD6.72mm)(pkt 10)
- Part No. 917D2458. Pinion. 12 tooth (for motor) 1.9mm Bore. (OD6.92mm)(pkt 10)
- Part No. 917D2460. Pulley. 14/10mm dia. 2.9mm bore.(pkt 10)
- Part No. 917D2461. Pulley. 30/25mm dia. 2.9mm bore.(pkt 10)
- Part No. 917D2462. Pulley. 30/25mm dia. 3.9mm bore with brass sleeve.(pkt 10)
- Part No. 917D2463. Pulley. 8/5.5 dia. 2.9mm bore. (pkt 10)
- Part No. 917D2501. Robotic Wheels - 25mm x 10mm. 2.6mm bore.(pkt 4)
- Part No. 917D2502. Robotic Wheels - 35mm x 7mm. 2.6mm bore.(pkt 4)
- Part No. 917D2504. Robotic Wheels - 51mm x 16mm. 2.6mm bore.(pkt 4)
- Part No. 917D2505. Robotic Wheels - 68mm x 20mm. 3.5mm bore.
- Part No. 917D2506. Robotic Wheels - 37mm x 16mm. 2.6mm bore.(pkt 4)
- Part No. 917D2507. Robotic Wheels - 44mm x 16mm. 2.6mm bore.(pkt 4)
- Part No. 917D2509. Robotic Wheels - 56mm x 16mm. 2.6mm bore.(pkt 4)
- Part No. 917D2513. Robotic Wheels - 54mm x 30mm. 2.6mm bore.
- Part No. 917D2515. 'O' Ring (70mm Diameter x 5mm).
- Part No. 917D2531. Perforated Metal Strip. (305mm x 8.75mm x 0.5mm)(pkt 5)
- Part No. 917D2540. Perforated Metal Sheet. (200mm x 110mm x 0.6mm)
- Part No. 917D2551. Shaft 3mm dia (long for output). (3mm x 110mm)(pkt 10)
- Part No. 917D2553. Shaft 3mm dia (short for intermediate). (3mm x 60mm)(pkt 10)
- Part No. 917D2682. Spacers (25mm).(pkt 10)
- Part No. 917D2683. Spacers (30mm).(pkt 10)

RACK & PINION SET. PT.NO. 917D/1.
Consisting of: 1 Rack (917D2430), 1 Pinion (917D2401) and Mounting Screws.

CHAIN & SPROCKET SET. PT.NO. 917D/3.
Consisting of:2 Sprockets(917D2445),2 Sprockets(917D2446)
& 1m approx Chain(917D2449)

CROWN WHEEL & PINION SET. PT.NO. 917D/5.
Consisting of: 1 Crown Wheel (917D2440) & 1 Pinion (917D2401).

PULLEY SET. PT. NO. 917D/7.
Consisting of: 1 each of Pulley (917D2460, 917D2461, 917D2462,
917D2463) Micro Switch operating Pin. (917D2417), & "O" Ring
(917D2515).

GEAR SET. PT.NO. 917D/2.
Consisting of:4 gears(917D2456),2 gears (917D2452) and 1 Pinion
(917D2458).

WORM DRIVE SET. PT.NO. 917D/4.
Consisting of:1 Worm drive(917D2420),& 1 Spur Gear(917D2404).

SPUR GEAR SET. PT.NO. 917D/6.
Consisting of: 1 each Spur Gear (917D2403, 917D2401 & 917D2404).

918D SERIES 25mm SINGLE RATIO METAL GEARBOX (RE280 MOTOR/RE 280/1 MOTOR)



WITH 2mm OUTPUT SHAFT (15:1 ONLY)



WITH 4mm OUTPUT SHAFT (ALL RATIOS)

RATIOS NOW AVAILABLE AS EX-STOCK ITEMS.

- 918D151 (1.5v - 3v) WITH RE 280 MOTOR (RATIO 15:1). 2mm SHAFT
- 918D151/1 (1.5v - 3v) WITH RE 280 MOTOR (RATIO 15:1). 4mm SHAFT
- 918D301/1 (1.5v - 3v) WITH RE 280 MOTOR (RATIO 30:1). 4mm SHAFT
- 918D1001/1 (1.5v - 3v) WITH RE 280 MOTOR (RATIO 100:1). 4mm SHAFT
- 918D2501/1 (1.5v - 3v) WITH RE 280 MOTOR (RATIO 250:1). 4mm SHAFT

- 918D15112 (12v - 24v) WITH RE 280/1 MOTOR (RATIO 15:1). 2mm SHAFT
- 918D15112/1 (12v - 24v) WITH RE 280/1 MOTOR (RATIO 15:1). 4mm SHAFT
- 918D30112/1 (12v - 24v) WITH RE 280/1 MOTOR (RATIO 30:1). 4mm SHAFT
- 918D100112/1 (12v - 24v) WITH RE 280/1 MOTOR (RATIO 100:1). 4mm SHAFT
- 918D250112/1 (12v - 24v) WITH RE280/1 MOTOR (RATIO 250:1). 4mm SHAFT
- 918D10241/1 (12v - 24v) WITH RE280/1 MOTOR (RATIO 1024:1) 4mm SHAFT

This miniature gearbox is of steel and brass construction with brass gears and is mounted on a 1mm thickness steel bracket. It incorporates a high quality three pole motor with sleeved bearings. The design and construction of the unit make it suitable for a host of model and light industrial applications.

MOTOR DATA. (RE-280 & RE-280/1)

MODEL	VOLTAGE		NO LOAD		AT MAXIMUM EFFICIENCY						STALL TORQUE	
	OPERATING RANGE	NOMINAL	SPEED	CURRENT	SPEED	CURRENT	TORQUE		OUTPUT	EFF	TORQUE	
			R.P.M.	A	R.P.M.	A	oz - in	g - cm	W	%	oz - in	g - cm
RE - 280	1.5 - 3.0	1.5v CONSTANT	4600	0.120	3750	0.53	0.160	11.53	0.44	56.2	0.86	62.0
RE - 280	1.5 - 3.0	3.0v CONSTANT	9200	0.155	7800	0.85	0.278	20.00	1.60	62.3	1.81	130.0
RE - 280/1	12 - 24	12v CONSTANT	8400	0.10	6300	0.30	0.347	25.0	1.62	44.87	1.389	100

REDUCTION TABLE. R.P.M.

SUPPLY VOLTAGE	1.5v	3.0v	6v	12v	18v	24v
918D151	306	613				
918D15112			280	560	840	1120
918D301	153	306				
918D30112			140	280	420	560
918D1001	46	92				
918D100112			42	84	126	168
918D2501	18	37				
918D250112			17	34	50	67
918D10241	4.5	9				
918D1024112			3	7	11	15

WEIGHT	
918D151	72g
918D15112	72g
918D301	72g
918D30112	72g
918D1001	72g
918D100112	72g
918D2501	72g
918D250112	72g

GEARBOX RATINGS

RATED TOLERANCE TORQUE (g.cm)	MAX. MOMENTARY TOLERANCE TORQUE
15:1	400
30:1	600
100:1	1000
250:1	1200
1024:1	1500

NOTE: To establish Torque Rating in nM, divide g.cm by 10,197.0

IMPORTANT NOTICE
Due to the wide range of applications for this product it is the users responsibility to establish the products suitability for their individual purpose(s).

918D SERIES 25mm SINGLE RATIO METAL GEARBOX

GEARBOX DIMENSIONS.

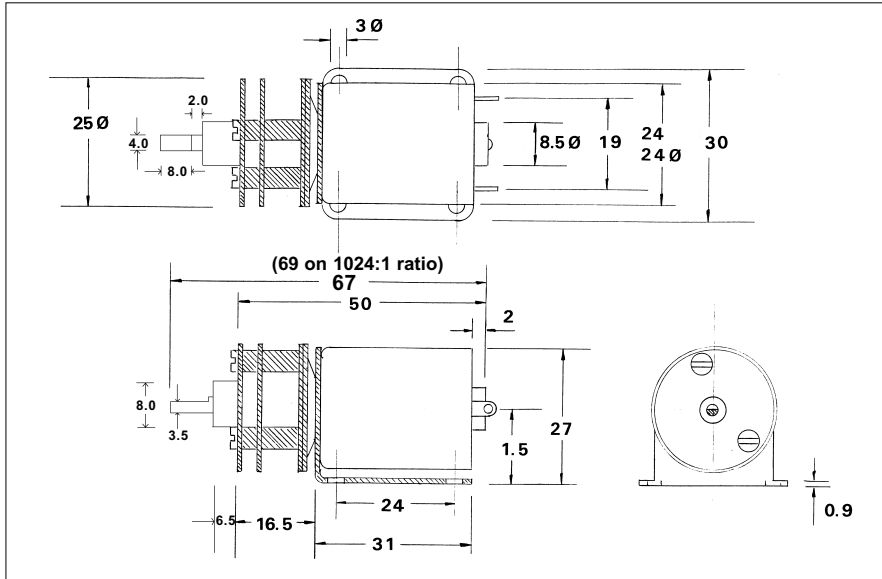

Part No. 1071. Anti vibration mount. M3



Part No. 918D8. Steel Shaft. 4mm OD x 150mm



Part No. 1105/61 Universal Coupling. 4mm - 4mm

ACCESSORIES FOR 918D SERIES GEARBOX.

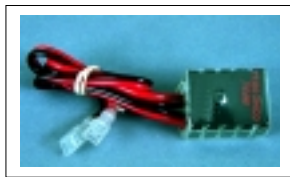

Part No. 917D9. Voltage Regulator. (6-15v DC Input, 3v, 1.5amp output)
Part No. 917D10. Voltage Regulator. (6-15v DC Input. 1.5v, 1.5amp output)
Part No. 917D11. Voltage Regulator. (6-15v DC Input. 4.5v, 1.5amp output) (Above for 280 motor only)

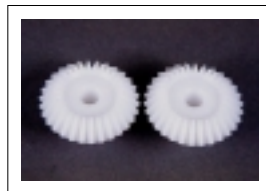

Part No. 918D7. Nylon Bevel Gears (1:1). O.D. 17.2mm. 4mm I.D.

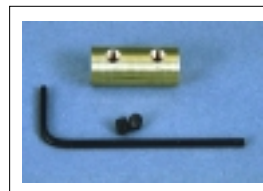

Part No. 918D1. In-Line Coupling. 2mm - 3mm. (Dia. 8mm x 18.4mm)
Part No. 918D1/1. In-Line Coupling 4mm - 4mm. (Dia. 8mm x 18.4mm)

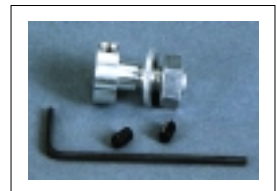

Part No. 918D4. Gear Adapter. 2mm I.D.
Part No. 918D4/1 Gear Adapter. 4mm I.D.



Part No. 917D2458. Pinions (Plastic) 12 tooth. 1.9mm I.D.



Part No. 918D2. Pulley. 2mm I.D. (25mm dia. x 14.75mm) (Aluminium)
Part No. 918D2/1. Pulley 4mm I.D. (25mm dia. x 14.75mm) (Aluminium)



Part No. 918D3. Pulley. 2mm I.D. (16mm dia. x 13.6mm) (Aluminium)
Part No. 918D3/1. Pulley 4mm I.D. (16mm dia x 13.6mm) (Aluminium)



Part No. 917D2515. "O" Ring 70mm x 5mm Dia.

Subject to minimum order quantities of 250 units, the following ratios are also available with a six week lead-time.

The physical dimensions of these other gearboxes may vary from the data as illustrated above. Details of individual gearboxes are available upon request.

GEARBOX 6:1	with RE280 motor (1.5v - 3v)	GEARBOX 6:1	with RE280/1 motor (12v - 24v)
GEARBOX 10:1	with RE280 motor (1.5v - 3v)	GEARBOX 10:1	with RE280/1 motor (12v - 24v)
GEARBOX 21:1	with RE280 motor (1.5v - 3v)	GEARBOX 21:1	with RE280/1 motor (12v - 24v)
GEARBOX 44:1	with RE280 motor (1.5v - 3v)	GEARBOX 44:1	with RE280/1 motor (12v - 24v)
GEARBOX 60:1	with RE280 motor (1.5v - 3v)	GEARBOX 60:1	with RE280/1 motor (12v - 24v)
GEARBOX 77:1	with RE280 motor (1.5v - 3v)	GEARBOX 77:1	with RE280/1 motor (12v - 24v)
GEARBOX 112:1	with RE280 motor (1.5v - 3v)	GEARBOX 112:1	with RE280/1 motor (12v - 24v)
GEARBOX 150:1	with RE280 motor (1.5v - 3v)	GEARBOX 150:1	with RE280/1 motor (12v - 24v)
GEARBOX 170:1	with RE280 motor (1.5v - 3v)	GEARBOX 170:1	with RE280/1 motor (12v - 24v)
GEARBOX 200:1	with RE280 motor (1.5v - 3v)	GEARBOX 200:1	with RE280/1 motor (12v - 24v)
GEARBOX 250:1	with RE280 motor (1.5v - 3v)	GEARBOX 250:1	with RE280/1 motor (12v - 24v)
GEARBOX 320:1	with RE280 motor (1.5v - 3v)	GEARBOX 320:1	with RE280/1 motor (12v - 24v)
GEARBOX 360:1	with RE280 motor (1.5v - 3v)	GEARBOX 360:1	with RE280/1 motor (12v - 24v)
GEARBOX 400:1	with RE280 motor (1.5v - 3v)	GEARBOX 400:1	with RE280/1 motor (12v - 24v)
GEARBOX 500:1	with RE280 motor (1.5v - 3v)	GEARBOX 500:1	with RE280/1 motor (12v - 24v)
GEARBOX 700:1	with RE280 motor (1.5v - 3v)	GEARBOX 700:1	with RE280/1 motor (12v - 24v)
GEARBOX 800:1	with RE280 motor (1.5v - 3v)	GEARBOX 800:1	with RE280/1 motor (12v - 24v)
GEARBOX 900:1	with RE280 motor (1.5v - 3v)	GEARBOX 900:1	with RE280/1 motor (12v - 24v)
GEARBOX 1153:1	with RE280 motor (1.5v - 3v)	GEARBOX 1153:1	with RE280/1 motor (12v - 24v)

919D SERIES 35mm SINGLE RATIO METAL GEARBOX

(RE 540/1 MOTOR)



RATIOS NOW AVAILABLE AS EX-STOCK ITEMS.

919D2.51	(4.5v - 15v)	WITH RE 540/1 MOTOR.	RATIO 2.5:1
919D61	(4.5v - 15v)	WITH RE 540/1 MOTOR.	RATIO 6:1
919D111	(4.5v - 15v)	WITH RE 540/1 MOTOR.	RATIO 11:1
919D501	(4.5v - 15v)	WITH RE 540/1 MOTOR.	RATIO 50:1
919D1001	(4.5v - 15v)	WITH RE 540/1 MOTOR.	RATIO 100:1
919D1481	(4.5v - 15v)	WITH RE 540/1 MOTOR.	RATIO 148:1
919D5001	(4.5v - 15v)	WITH RE 540/1 MOTOR.	RATIO 500:1
919D8101	(4.5v - 15v)	WITH RE 540/1 MOTOR.	RATIO 810:1
919D30001	(4.5v - 15v)	WITH RE 540/1 MOTOR.	RATIO 3000:1

IMPORTANT NOTICE
Due to the wide range of applications for this product it is the users responsibility to establish the products suitability for their individual purpose(s).

Designed for heavy-duty industrial and model applications this robust unit boasts a powerful high quality, three pole motor with sintered bronze bearings. The metal gearbox incorporates sleeved bearings, enabling the high torque transfer from the motor to be transmitted through the gearbox. The unit is mounted on a 1mm thick plated steel bracket.

MOTOR DATA. (RE-540/1)

MODEL	VOLTAGE		NO LOAD		AT MAXIMUM EFFICIENCY						STALL TORQUE	
	OPERATING RANGE	NOMINAL	SPEED	CURRENT	SPEED	CURRENT	TORQUE		OUTPUT	EFF	STALL TORQUE	
			R.P.M.	A	R.P.M.	A	oz - in	g - cm	W	%	oz - in	g - cm
RE - 540/1	4.5 - 15.0	6.0v CONSTANT	7500	0.45	6180	2.1	1.64	118.2	7.49	59.4	9.31	670
		12.0v CONSTANT	15800	0.52	13360	2.85	2.14	154.4	21.2	61.9	13.9	1000

REDUCTION TABLE. R.P.M.

SUPPLY VOLTAGE	4.5v	6.0v	9.0v	12.0v	15.0v
919D2.51	2250	3000	4500	6300	7900
919D61	990	1316	1975	2633	3295
919D111	540	718	1077	1436	1800
919D501	120	158	237	316	395
919D1001	59	79	119	158	198
919D1481	40	53	80	106	132
919D5001	9.75	14	21.5	30	37.5
919D8101	8	10	15	20	25
919D30001	1.5	2	3	5	6

WEIGHT	
919D2.51	240g
919D61	234g
919D111	238g
919D501	246g
919D1481	255g
919D5001	260g
919D8101	255g
919D30001	262g

GEARBOX RATINGS

	RATED TOLERANCE TORQUE (g.cm)	MAX. MOMENTARY TOLERANCE TORQUE
2.5:1	2000	6000
6:1	3000	9000
11:1	3000	9000
50:1	3000	9000
100:1	6000	18000
148:1	6000	18000
500:1	6000	18000
810:1	6000	18000
3000:1	6000	18000

24 volt versions are available for this range of motor-gearboxes. Performance data is similar to 12 volt versions. This version also has an extended 10mm rear shaft to accommodate motor encoders. When ordering please use 12v version part number suffixed with 24V. I.E. 919D111 will be 919D11124V

NOTE: To establish Torque Rating in nM, divide g.cm by 10,197.0

919D SERIES 35mm SINGLE RATIO METAL GEARBOX

(RE 540/1 MOTOR)

GEARBOX DIMENSIONS

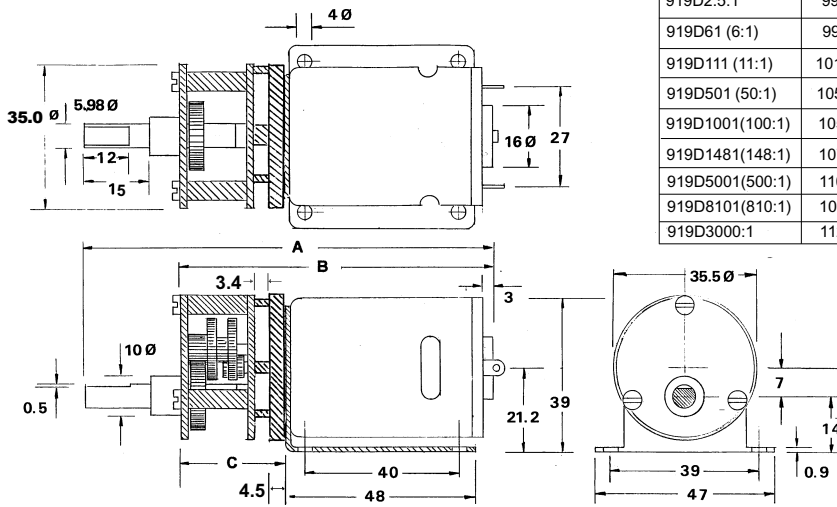

GEARBOX REF.	A	B	C
919D2.5:1	99	73	20
919D61 (6:1)	99	73	20
919D111 (11:1)	101	76	22
919D501 (50:1)	105	80	26
919D1001(100:1)	105	80	26
919D1481(148:1)	107	82	28
919D5001(500:1)	110	85	31
919D8101(810:1)	109	94	30
919D3000:1	112	97	33



Part No. 1071. Anti vibration mount. M3



Part No. 919D30 Bearing Blocks. 5mm I.D. (19.06 x 19.0mm x 10mm)

Part No. 919D26 Steel shaft 5mmOD x 150mm



Part No. 919D29 Double ended motor mount.

Part No. 919D30/1 Bearing Blocks. 6mm I.D. (15.87 x 19.0mm x 12.5mm)

Part No. 919D30/2 Bearing Blocks. 8mm I.D. (19.0 x 19.0mm x 13.0mm)

Part No. 919D26/2 Steel Shaft 8mmOD x 150mm

Part No. 919D26/1 Steel Shaft 6mmOD x 150mm

TIMING PULLEYS

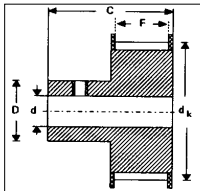

TIMING BELTS



FOR FURTHER DETAILS SEE PAGE. 20

Part No. 919D7 - 14. Timing Pulleys.

Part No. 919D15 - 23. Timing Belts

Pt. No.	No. of teeth	d	dk	F	C	D
919D7/10	10	3	15.05	12	21.0	10
919D7/12	12	3	18.25	12	21.0	12
919D7	14	4	21.45	12	21.0	12
919D8	16	4	24.60	12	21.0	15
919D9	20	4	31.00	12	21.0	15
919D10	25	4	39.00	12	21.0	15
919D11	30	4	46.95	12	21.0	15
919D12	35	4	54.85	12	21.0	15
919D13	40	4	62.85	12	21.0	15
919D14	44	4	69.20	12	21.0	15

Please note. Dimension 'd' is an industry standard 4mm pilot hole. You will need to enlarge this to the size you require.

Pt. No.	Length (Circum)	Width
919D15	165	9.8
919D16	185	9.8
919D17	200	9.8
919D18	305	9.8
919D19	390	9.8
919D20	455	9.8
919D21	545	9.8
919D22	630	9.8
919D23	840	9.8

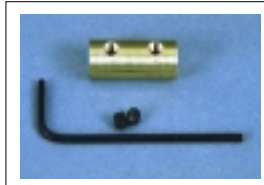

Pt No. 919D1. In-Line Coupling. 6mm - 6mm. (Dia. 12.67mm x 24.8mm)

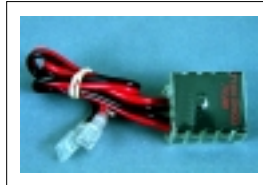

Pt No. 919D2. Voltage Regulator. (6-15v DC Input. 4v-12v output). 26mm x 31mm x 15.5mm

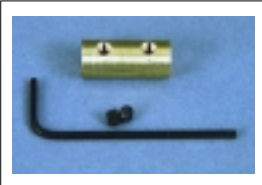

Pt No. 919D1/2. In-line Coupling. 6mm-8sw (Meccano) Dia. 12.67mm x 24.8mm



Pt No. 919D4. Pulley 25mm dia. (Aluminium)

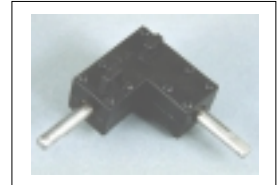

Pt.No.919D24. Bevel Gearbox. (Right Angle)

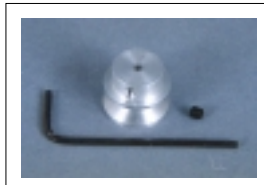

Pt No. 919D5. Pulley 16mm dia. (Aluminium)

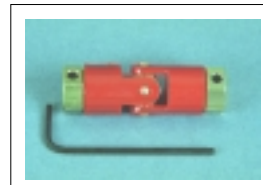

Pt No. 1105/60. Universal Coupling. 6mm - 6mm.

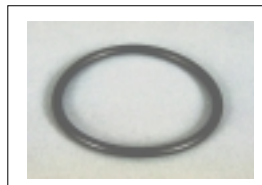

Pt No. 917D2515. "O" Ring 70mm x 5mm Dia.

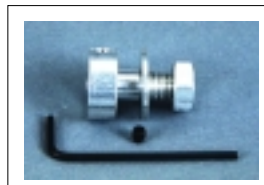

Pt No. 919D27. Gear Adapter.

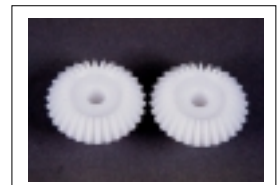

Pt No. 919D25. Nylon Bevel Gears 1:1. OD30.7mm ID 6mm

Subject to minimum order quantities of 250 units, the following ratios are also available with a six week lead-time. The physical dimensions of these other gearboxes may vary from the data as illustrated above. Details of individual gearboxes are available upon request.

- GEARBOX 10:1 WITH 540/1 MOTOR
- GEARBOX 60:1 WITH 540/1 MOTOR
- GEARBOX 90:1 WITH 540/1 MOTOR
- GEARBOX 180:1 WITH 540/1 MOTOR
- GEARBOX 300:1 WITH 540/1 MOTOR
- GEARBOX 450:1 WITH 540/1 MOTOR
- GEARBOX 700:1 WITH 540/1 MOTOR
- GEARBOX 1000:1 WITH 540/1 MOTOR

- GEARBOX 18:1 WITH 540/1 MOTOR.
- GEARBOX 70:1 WITH 540/1 MOTOR.
- GEARBOX 100:1 WITH 540/1 MOTOR
- GEARBOX 200:1 WITH 540/1 MOTOR
- GEARBOX 350:1 WITH 540/1 MOTOR
- GEARBOX 500:1 WITH 540/1 MOTOR
- GEARBOX 750:1 WITH 540/1 MOTOR
- GEARBOX 1500:1 WITH 540/1 MOTOR

- GEARBOX 30:1 WITH 540/1 MOTOR.
- GEARBOX 75:1 WITH 540/1 MOTOR.
- GEARBOX 120:1 WITH 540/1 MOTOR
- GEARBOX 250:1 WITH 540/1 MOTOR
- GEARBOX 400:1 WITH 540/1 MOTOR
- GEARBOX 600:1 WITH 540/1 MOTOR
- GEARBOX 900:1 WITH 540/1 MOTOR

940D SERIES 32mm PLANETRY (EPICYCLIC) METAL GEARBOX

(RE 385 MOTOR)



IMPORTANT NOTICE
Due to the wide range of applications for this product it is the users responsibility to establish the products suitability for their individual purpose(s).

RATIOS NOW AVAILABLE AS EX-STOCK ITEMS.

940D51	(4.5v - 15v)	RATIO 5:1
940D1001	(4.5v - 15v)	RATIO 100:1
940D2641	(4.5v - 15v)	RATIO 264:1
940D5161	(4.5v - 15v)	RATIO 516:1

Designed for heavy-duty industrial and model applications this robust unit boasts a powerful high quality, five pole motor with sintered bronze bearings. The metal gearbox incorporates sleeved bearings, enabling the high torque transfer from the motor to be transmitted through the gearbox.

MOTOR DATA. (RE-385)

MODEL	VOLTAGE		NO LOAD		AT MAXIMUM EFFICIENCY						STALL TORQUE	
	OPERATING RANGE	NOMINAL	SPEED	CURRENT	SPEED	CURRENT	TORQUE		OUTPUT	EFF	oz - in	g - cm
			R.P.M.	A	R.P.M.	A	oz - in	g - cm	W	%		
RE - 385	6.0 - 15.0	12v CONSTANT	11000	0.155	9281	0.837		65.3	6.21	61.85		417.6

REDUCTION TABLE. R.P.M.

SUPPLY VOLTAGE	4.5v	6.0v	9.0v	12.0v	15.0v
940D51	700	1000	1600	2150	2800
940D1001	35	50	77	103	134
940D2641	12	19	30.5	41	54.5
940D5161	6	8.5	14	19	25

WEIGHT	
940D51	167g
940D1001	214g
940D2641	235g
940D5161	239g

GEARBOX RATINGS

RATED TOLERANCE TORQUE (g.cm)	MAX. MOMENTARY TOLERANCE TORQUE
5:1 2000	6000
100:1 12000	36000
264:1 12000	36000
516:1 12000	36000

NOTE: To establish Torque Rating in nM, divide g.cm by 10,197.0

MOTOR DATA. (RE-385/24v). Current at stall 2.26A

MODEL	VOLTAGE		NO LOAD		AT MAXIMUM EFFICIENCY						STALL TORQUE	
	OPERATING RANGE	NOMINAL	SPEED	CURRENT	SPEED	CURRENT	TORQUE		OUTPUT	EFF	oz - in	g - cm
			R.P.M.	A	R.P.M.	A	oz - in	g - cm	W	%		
RE - 385/24v	12 - 24v	12v CONSTANT	11000	0.065	9481	0.386		65.3	6.35	68.46		447.7

24 volt versions are available for this range of motor-gearboxes. Performance data is similar to 12 volt versions. This version also has an extended 10mm rear shaft to accommodate motor encoders. When ordering please use 12v version part number suffixed with 24V. I.E. 940D1001 will be 940D100124V

940D SERIES 32mm PLANETRY (EPICYCLIC) METAL GEARBOX

GEARBOX DIMENSIONS

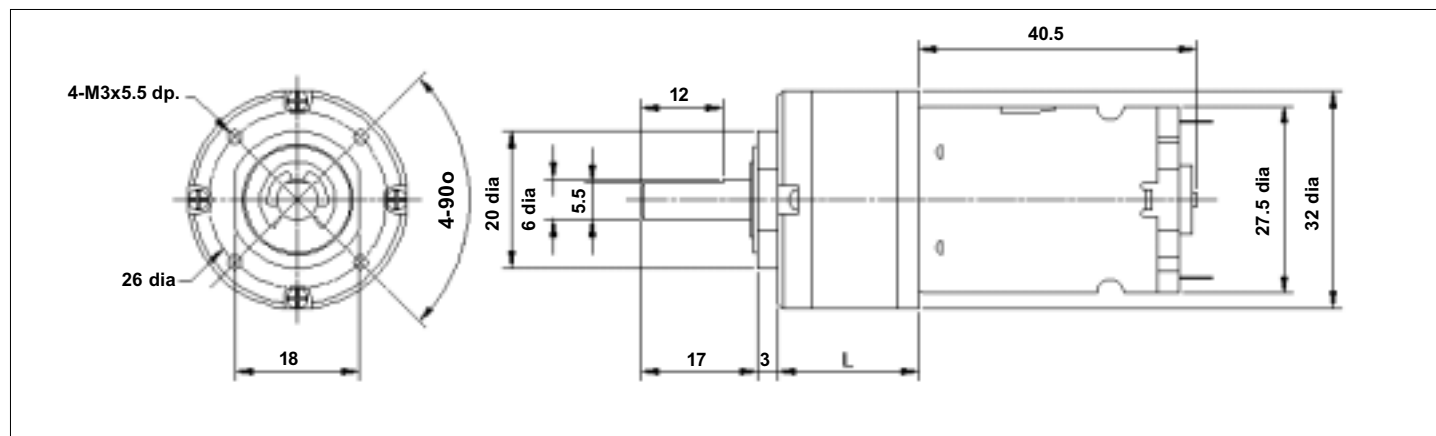

GEARBOX REF.	L
940D51 (5:1)	20.8
940D1001 (100:1)	33.6
940D2641 (264:1)	40.0
940D5161 (516:1)	40.0

FOR ACCESSORIES TO FIT THIS SERIES GEARBOX, REFER TO 919D SERIES PAGE.

ADVANTAGES OF PLANETARY GEARBOXES.	
EFFICIENCY:	Efficiencies of planetary gearboxes can be above 90% while some other types of transmission can be 50% or less. This allows the use of smaller motors.
SIZE:	Planetary gearboxes can be half the size of conventional boxes.
WEIGHT:	Weight savings can be as high as 60%, allowing smaller, lighter support structures.
MAINTENANCE:	Other than routine oil changes, no maintenance is required, eliminating the need to hold spares.
REVERSIBLE:	Planetary gears can be equally efficient in either direction. This is an advantage for use in running machinery in both clockwise and anti-clockwise directions.
COAXIAL:	The coaxial configuration of input and output shafts allows planetary gears to be installed in line with a motor and a machine.

Subject to minimum order quantities of 100 units, the following ratios are also available with a six week lead-time. The physical dimensions of these other gearboxes may vary from the data as illustrated above. Details of individual gearboxes are available upon request.

- | | |
|------------------------------|------------------------------|
| GEARBOX 14:1 WITH 385 MOTOR | GEARBOX 19:1 WITH 385 MOTOR. |
| GEARBOX 27:1 WITH 385 MOTOR. | GEARBOX 35:1 WITH 385 MOTOR |
| GEARBOX 51:1 WITH 385 MOTOR | GEARBOX 71:1 WITH 385 MOTOR. |
| GEARBOX 139:1 WITH 385 MOTOR | GEARBOX 189:1 WITH 385 MOTOR |
| GEARBOX 264:1 WITH 385 MOTOR | GEARBOX 721:1 WITH 385 MOTOR |
| GEARBOX 939:1 WITH 385 MOTOR | |

941D SERIES 16mm PLANETRY (EPICYCLIC) SUB MINIATURE METAL GEARBOX



IMPORTANT NOTICE
Due to the wide range of applications for this product it is the users responsibility to establish the products suitability for their individual purpose(s).

RATIOS NOW AVAILABLE AS EX-STOCK ITEMS.

941D41	(1.5v - 12v)	RATIO 4:1
941D621	(1.5v - 12v)	RATIO 62:1
941D1041	(1.5v - 12v)	RATIO 104:1
941D2311	(1.5v - 12v)	RATIO 231:1
941D10141	(1.5v - 12v)	RATIO 1014:1

Designed for heavy-duty industrial and model applications this robust unit boasts a powerful high quality motor with sintered bronze bearings. The metal gearbox incorporates sleeved bearings, enabling the high torque transfer from the motor to be transmitted through the gearbox.

MOTOR DATA.

MODEL	VOLTAGE		NO LOAD		MAX EFFICIENCY						STALL TORQUE	
	OPERATING RANGE	NOMINAL	SPEED	CURRENT	SPEED	CURRENT	TORQUE		OUTPUT	EFF	g - cm	
			R.P.M.	mA	R.P.M.	mA	oz - in	g - cm	W	%		
(941D)	1.5 - 12.0	12.0v CONSTANT	8000	19	5881	70		8.68	0.5	63.26		26

REDUCTION TABLE. R.P.M.

SUPPLY VOLTAGE		3.0v	6.0v	9.0v	12.0v
941D41		350	800	1300	1800
941D621		18	50	82	119
941D1041		12.5	30	50	70
941D2311		5	14	23	32
941D10141		1.25	3.10	5	6.8

WEIGHT	
941D41	37g
941D621	45g
941D1041	43g
941D2311	49g
941D10141	50g

NOTE: It is not recommended to run the motor/gearbox combination at 1.5v

GEARBOX RATINGS

RATED TOLERANCE TORQUE (g.cm)		MAX. MOMENTARY TOLERANCE TORQUE
4:1	1000	3000
62:1	2000	6000
104:1	2000	6000
231:1	2500	7500
1014:1	3000	9000

24 volt versions are available for this range of motor-gearboxes. Performance data is similar to 12 volt versions. This version also has an extended 10mm rear shaft to accommodate motor encoders. When ordering please use 12v version part number suffixed with 24V. I.E. 941D621 will be 941D62124V

NOTE: To establish Torque Rating in nM, divide g.cm by 10,197.0

941D SERIES 16mm PLANETRY (EPICYCLIC) SUB MINIATURE METAL GEARBOX

GEARBOX DIMENSIONS

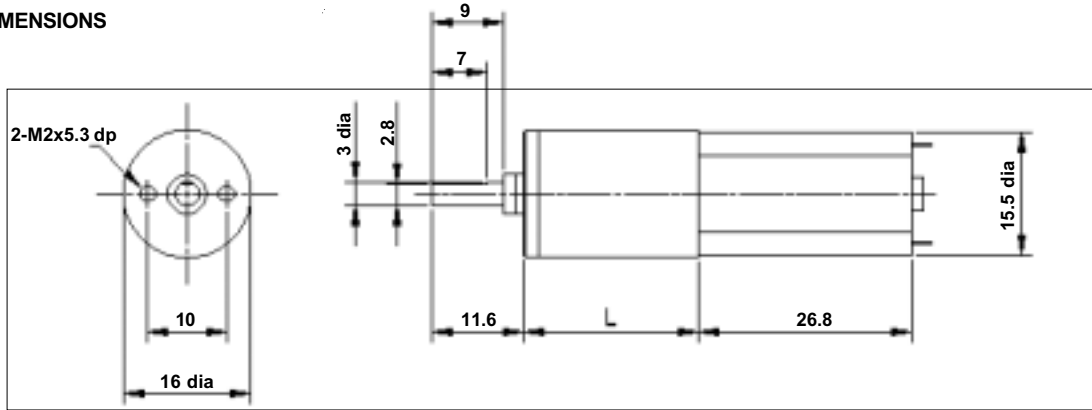

GEARBOX REF.	L
941D41 (4:1)	15
941D621 (62:1)	22.2
941D2311 (231:1)	25.8
941D10141 (1014:1)	29.7

FOR ACCESSORIES TO FIT THIS SERIES GEARBOX, REFER TO 917D SERIES PAGE.

ADVANTAGES OF PLANETARY GEARBOXES.	
EFFICIENCY:	Efficiencies of planetary gearboxes can be above 90% while some other types of transmission can be 50% or less. This allows the use of smaller motors.
SIZE:	Planetary gearboxes can be half the size of conventional boxes.
WEIGHT:	Weight savings can be as high as 60%, allowing smaller, lighter support structures.
MAINTENANCE:	Other than routine oil changes, no maintenance is required, eliminating the need to hold spares.
REVERSIBLE:	Planetary gears can be equally efficient in either direction. This is an advantage for use in running machinery in both clockwise and anti-clockwise directions.
COAXIAL:	The coaxial configuration of input and output shafts allows planetary gears to be installed in line with a motor and a machine.

Subject to minimum order quantities of 100 units, the following ratios are also available with a six week lead-time. The physical dimensions of these other gearboxes may vary from the data as illustrated above. Details of individual gearboxes are available upon request.

- | | |
|---------------------------|---------------------------|
| GEARBOX 14:1 WITH MOTOR | GEARBOX 19:1 WITH MOTOR |
| GEARBOX 29:1 WITH MOTOR | GEARBOX 72:1 WITH MOTOR |
| GEARBOX 84:1 WITH MOTOR | GEARBOX 104:1 WITH MOTOR |
| GEARBOX 128:1 WITH MOTOR | GEARBOX 157:1 WITH MOTOPR |
| GEARBOX 316:1 WITH MOTOR | GEARBOX 370:1 WITH MOTOR |
| GEARBOX 455:1 WITH MOTOR | GEARBOX 561:1 WITH MOTOR |
| GEARBOX 690:1 WITH MOTOR | GEARBOX 1621:1 WITH MOTOR |
| GEARBOX 1996:1 WITH MOTOR | GEARBOX 3027:1 WITH MOTOR |

942D SERIES 32mm (36mm motor) PLANETRY (EPICYCLIC) METAL GEARBOX

(RE 540/1 MOTOR)



IMPORTANT NOTICE
Due to the wide range of applications for this product it is the users responsibility to establish the products suitability for their individual purpose(s).

RATIOS NOW AVAILABLE AS EX-STOCK ITEMS.

942D51	(4.5v - 15v)	RATIO 5:1
942D1001	(4.5v - 15v)	RATIO 100:1
942D2641	(4.5v - 15v)	RATIO 264:1
942D5161	(4.5v - 15v)	RATIO 516:1

Designed for heavy-duty industrial and model applications this robust unit boasts a powerful high quality motor with sintered bronze bearings. The metal gearbox incorporates sleeved bearings, enabling the high torque transfer from the motor to be transmitted through the gearbox.

MOTOR DATA.

MODEL	VOLTAGE		NO LOAD		MAX EFFICIENCY						STALL TORQUE	
	OPERATING RANGE	NOMINAL	SPEED	CURRENT	SPEED	CURRENT	TORQUE		OUTPUT	EFF	g - cm	
			R.P.M.	A	R.P.M.	A	oz - in	g - cm	W	%		
540/1	4.5 - 15.0	12.0v CONSTANT	15,800	0.52	13360	2.85	2.14	154.4	21.2	61.9	13.9	1000

REDUCTION TABLE. R.P.M.

SUPPLY VOLTAGE	4.5v	6.0v	9.0v	12.0v	15.0v
942D51	1082	1502	2287	3090	3640
942D1001	51	71	108	146	172
942D2641	18	25.5	39.5	53	68
942D5161	9.5	13	20	27	32

WEIGHT	
942D51	254g
942D1001	303g
942D2641	329g
942D5161	333g

GEARBOX RATINGS

RATED TOLERANCE TORQUE (g.cm)		MAX MOMENTARY TOLERANCE TORQUE
5:1	2000	6000
100:1	12000	36000
264:1	12000	36000
516:1	12000	36000

24 volt versions are available for this range of motor-gearboxes. Performance data is similar to 12 volt versions. This version also has an extended 10mm rear shaft to accommodate motor encoders. When ordering please use 12v version part number suffixed with 24V. I.E. 942D1001 will be 942D100124V

NOTE: To establish Torque Rating in nM, divide g.cm by 10,197.0

MOTOR DATA. (RE-540/1 24v).

MODEL	VOLTAGE		NO LOAD		AT MAXIMUM EFFICIENCY						STALL TORQUE	
	OPERATING RANGE	NOMINAL	SPEED	CURRENT	SPEED	CURRENT	TORQUE		OUTPUT	EFF	oz - in	g - cm
			R.P.M.	A	R.P.M.	A	oz - in	g - cm	W	%		
RE - 540/1 24v	12 - 24v	24v CONSTANT	14452	0.30	12111	1.57		177	22	65		1094